

Digital Videocassette Recorder

Operating Instructions

Before operating the unit, please read this manual thoroughly and retain it for future reference.



DSR-70A/70AP

Owner's Record

The model and serial numbers are located in the rear. Record these numbers in the spaces provided below. Refer to them whenever you call upon your Sony dealer regarding this product.

Model No. _____ Serial No. _____

WARNING

To prevent fire or shock hazard, do not expose the unit to rain or moisture.

To avoid electrical shock, do not open the cabinet. Refer servicing to qualified personnel only.

For customers in the U.S.A (DSR-70A only)

This equipment has been tested and found to comply with the limits for a Class A digital device, pursuant to Part 15 of the FCC Rules. These limits are designed to provide reasonable protection against harmful interference when the equipment is operated in a commercial environment. This equipment generates, uses, and can radiate radio frequency energy and, if not installed and used in accordance with the instruction manual, may cause harmful interference to radio communications. Operation of this equipment in a residential area is likely to cause harmful interference in which case the user will be required to correct the interference at his own expense.

You are cautioned that any changes or modifications not expressly approved in this manual could void your authority to operate this equipment.

The shielded interface cable recommended in this manual must be used with this equipment in order to comply with the limits for a digital device pursuant to Subpart B of Part 15 of FCC Rules.

Caution

Television programs, films, video tapes and other materials may be copyrighted. Unauthorized recording of such material may be contrary to the provisions of the copyright laws.

For customers in Europe (DSR-70AP only)

This product with the CE marking complies with the EMC Directive (89/336/EEC) issued by the Commission of the European Community.

Compliance with this directive implies conformity to the following European standards:

- EN55103-1: Electromagnetic Interference (Emission)
- EN55103-2: Electromagnetic Susceptibility (Immunity)

This product is intended for use in the following Electromagnetic Environment(s):

E1 (residential), E2 (commercial and light industrial), E3 (urban outdoors) and E4 (controlled EMC environment, ex. TV studio).

For customers in the USA and Canada

RECYCLING LITHIUM-ION BATTERIES



You can help preserve our environment by returning your used rechargeable batteries to the collection and recycling location nearest you.

For more information regarding recycling of rechargeable batteries, call toll free 1-800-822-8837, or visit <http://www/rbc.org/>.

Caution: Do not handle damaged or leaking Lithium-Ion batteries.

RECYCLING NICKEL-CADMIUM BATTERIES



You can help preserve our environment by returning your used rechargeable batteries to the collection and recycling location nearest you.

Note: In some areas the disposal of Nickel-Cadmium batteries in household or business trash may be prohibited.

For more information regarding recycling of rechargeable batteries, call toll free 1-800-822-8837, or visit <http://www/rbr.org/>.

Caution: Do not handle damaged or leaking Nickel-Cadmium batteries.

Voor de Klanten in Nederland

- Dit apparaat bevat een vast ingebouwde batterij die niet vervangen hoeft te worden tijdens de levensduur van het apparaat.
- Raadpleeg uw leverancier indien de batterij toch vervangen moet worden.
De batterij mag alleen vervangen worden door vakbekwaam servicepersoneel.
- Gooi de batterij niet weg maar lever deze in als klein chemisch afval (KCA).
- Lever het apparaat aan het einde van de levensduur in voor recycling, de batterij zal dan op correcte wijze verwerkt worden.



Table of Contents

Chapter 1

Overview

Features	9
System Configuration	14
Location and Function of Parts	15
Display Panel	16
Control Panel	18
Front Control Section	24
Top Panel	25
Rear Panel	26

Chapter 2

Power Preparations

Power Preparations	31
Usable Batteries	31
Using the BP-L60(A)/L90(A) Battery Pack	32
Using the BP-90(A) Battery Pack	33
Using AC Power	34

Chapter 3

Recording and Playback

Handling Cassettes	37
Loading/Ejecting Cassettes	40
Recording	42
Preparations for Recording	42
Recording Operation	42
Sequential Recording Using Two Units	43
Parallel Recording Using Two Units	44
Two-Input Switched Video Recording (Optional DSBK-180/180P Required)	46
Digitally Dubbing Signals in DVCAM Format (Optional DSBK-140/150/160A Required)	50
Playback	55
Preparations for Playback	55
Playback Operation	56
Two-Unit Synchronous Playback	57

Chapter 4

Time Data and Sub LCD Menu

Setting Time Data	59
Information Displayed on the LCD Monitor	59
Setting an Initial Value and Recording Timecode	61
Synchronizing the Internal Timecode Generator With an External Signal — External Lock	63
Sub LCD Menu Display and Settings — Making Operating Mode and Video/Audio Signal Settings	64
Sub LCD Menu Home Page and Sub LCD Operation Buttons	64
Sub LCD Menu Basic Operations	66
Input and Output Settings for Video and Audio Signals — Sub LCD Menu	68
Making Settings in the Audio Settings Pages	68
Making Settings in the Audio Settings Subpages	69
Making Settings in the Video Settings Page	70
General Settings Pages of the Sub LCD Menu	71

Chapter 5

Editing

Sequence of Editing Operations	73
Settings for Editing	74
Recorder Settings	74
Player Settings	76
Selecting an Edit Mode	77
Assemble Editing	77
Insert Editing	77
Finding Edit Points — Search	79
Setting Edit Points	80
Setting Edit Points	80
Checking Edit Points	81
Cuing Up Edit Points	81
Previewing Edit Results	82
Modifying Edit Points	83
Setting Edit Points Using the Recorder Only	83

(Continued)

Table of Contents

Chapter 5

Editing (Continued)

Executing an Edit	84
Outline of Editing Operations	84
Starting an Edit	84
Redoing an Edit	85
DMC Editing	87
Overview of DMC Editing	87
Setting Edit Points and Playback Speeds	88
Executing DMC editing	89
Special Editing	90
Quick Editing	90
Continuous Editing	91
Manual Editing	92

Chapter 6

ClipLink Operation

Overview of ClipLink Operation	93
Displaying ClipLink Log Data	94
Detailed Data Display	94
Cuing Up to Mark IN/OUT and Cue Points	95
Cuing Up to Any Desired Position	95
Cuing Up to Adjacent Mark IN/Cue Points	95
Rewriting ClipLink Log Data	96
Changing the Reel Number	96
Changing Mark IN/OUT Points	96
Changing the OK/NG Status	97
Adding to/Deleting From ClipLink Log Data	99
Adding Mark IN/OUT Points	99
Deleting Mark IN/OUT Points	99
Automatically Creating New ClipLink Log Data	101

Chapter 7

Setup Menu

Menu System Configuration	103
Basic Menu	103
Items in the Basic Menu	103
Basic Menu Operations	106
Extended Menu	109
Items in the Extended Menu	109
Extended Menu Operations	117

Chapter 8

Connections and Settings

Reference Video Signals for Analog Signal Editing	119
Connections for Cut Editing Using Two DSR-70A/70AP Units — i.LINK Connections (Optional DSBK-140/160A Required)	120
Connections for Digital Nonlinear Editing Using SDTI (QSDI) Interface (Optional DSBK-150 Required)	121
Connections for Cut Editing Using SDI Interface (Optional DSBK-160A Required)	122
Settings Required When Connecting an External Editing Control Unit	122
Timecode Settings on This Unit	122
Settings on Editing Control Units	123
Connections for Component Analog Recording (Optional DSBK-170 Required)	124
Connections for Sequential Recording Using Two Units	125
Connections for Parallel Recording Using Two Units	127
Connections for Two-Unit Synchronous Playback	129
Connections for Two-Input Switched Video Recording (Optional DSBK-180/180P Required)	130
Connections for Digitally Dubbing Signals in DVCAM Format (Optional DSBK-140/150/160A Required)	131
Combining Two VCRs	132
Using the Shoulder Belt	133

Table of Contents

Chapter 9

Maintenance and Troubleshooting

Condensation	135
Head Cleaning	135
Periodic Maintenance	136
Troubleshooting	137
Error Messages	139
Alarm Messages	139

Appendixes

Specifications	143
ClipLink™ Guide	147
What Is ClipLink?	147
Example System Configuration and Operation Flow	148
Data Generated When Shooting	149
Glossary	152
Index	155

Overview

Features

The DSR-70A/70AP is a 1/4-inch digital videocassette recorder using the DVCAM™ digital recording format. It uses a component video system, with separate luminance and chrominance signals and digital processing to realize a stable, high image quality. This unit is lightweight and compact, with a color liquid crystal display and speakers, making it easy to carry, yet ideal for on-the-spot checking of recorded material.

By combining two units, you can easily assemble a cut editing system.

The unit supports the Sony-developed ClipLink™ function, improving operating efficiency when combined with a Sony EditStation™.

A range of optional interface boards is available, with support for both digital and analog systems.

The following are the principal features of the unit.

DVCAM Format

DVCAM is a professional 1/4-inch digital recording format developed by Sony from the DV 4:1:1 component digital format for home use.

High image quality and high stability

The luminance and chrominance signals are encoded separately, with a 1/5 compression, giving a stable high quality video image.

Since this is a digital system, nth-generation copies created by repeated dubbing show virtually no loss in picture quality.

Wide track

The recording track width is 15 μm, 50% wider than the 10 μm of the DV format. This ensures adequate reliability for professional use.

PCM digital audio for high sound quality

The PCM encoding method yields a high audio quality, with wide dynamic range and high signal-to-noise ratio.

There are two recording modes: two-channel mode (48-kHz sampling and 16-bit quantization), which offers sound quality equivalent to the DAT (Digital Audio Tape) format, or four-channel (32-kHz sampling and 12-bit quantization).

Playback compatibility with DV and DVCPRO formats

A DV cassette recorded on a DV format VCR as well as a DVCPRO (25M) format recorded cassette can be played back on this unit.

Note

When playing back a tape recorded in DVCPRO (25M) format, the SDTI and i.LINK outputs (*see the section “Digital interfaces” on this page*) of this unit are muted. Furthermore, it is not possible to playback the cue-audio track of the tape.

Support for three cassette sizes

There are two sizes of DVCAM cassette: standard and mini. You can use either size with this unit. The unit also accepts L and M sizes of DVCPRO (25M) cassette.

- The reel mechanism automatically adjusts to the size of cassette inserted.
- The capacity of a standard cassette is 184 minutes of recording/playback, and that of a mini cassette is 40 minutes.

Variety of Interfaces

Digital interfaces (options)

The unit can use the following digital interfaces provided by optional interface boards (*see page 12*).

- **SDTI (QSDI)¹⁾**
This interface allows video, audio and timecode signals in SDTI (QSDI) format to be transferred at normal speed between this unit and the ES-7 EditStation. When this unit is connected to another DVCAM VCR, it is possible to copy compressed signals between the two VCRs. (Optional DSBK-150 board)

- **SDI²⁾**
This interface allows the unit to input or output D1 (component) digital video and audio signals. (Optional DSBK-160A board)
- **i.LINK (DV)³⁾**
The DV input/output connector using i.LINK technology allows the unit to input and output digital video and audio signals in DV format. (Optional DSBK-140/160A board)

Analog interfaces

A wide range of analog interfaces is provided, allowing this unit to be connected to various video and audio devices.

- **Analog video:** Composite and S-video interfaces are provided. There is also a component interface option (DSBK-170).
- **Analog audio:** There are two input channels and two output channels. There is also support for microphone input.

Full Functionality for More Efficient Editing

This unit has functions which assist in efficient and precise editing.

With two DSR-70A/70AP units together, you can carry out automatic or manual editing, using either assemble or insert editing.

The system also provides a powerful range of functions for setting and amending edit points, preview, review, and other aspects of efficient editing.

DMC (dynamic motion control) editing

You can save a varying speed, in the range $-1/2$ to $+1/2$ times normal speed, for an editing segment, and automatically edit with this varying speed.

1) SDTI (QSDI): SDTI (Serial Data Transport Interface) is the name of a standard interface established as SMPTE 305M.

This unit uses SDTI to transmit DV data, and the input/output connectors are labeled “SDTI(QSDI).” In indicator and menu indications, however, the “SDTI(QSDI)” name is shortened to “SDTI.”

2) SDI: Serial Digital Interface is used for transferring video signals in component digital format (D1).

3) **i** is a trademark of Sony Corporation and indicates that this product is in agreement with IEEE1394-1995 specifications and their revisions.

Split editing

In insert editing, this allows the audio IN point to be set separately from the video IN and OUT points.

Support for ClipLink function

This unit accepts instructions from an EditStation, to transfer to the EditStation ClipLink log data held in the cassette memory or index pictures recorded on the tape. On the EditStation you can use these images and data to carry out editing operations efficiently.

- Displaying ClipLink log data
- Changing ClipLink log data OK/NG status
- Cuing up to Mark IN and cue points provided by ClipLink log data
- For cut editing, copying Mark IN data from ClipLink log data

For an overview of the ClipLink function, see the appendix “ClipLink Guide” (page 147).

Internal timecode generator and reader

An internal timecode generator and reader enables timecode compliant with SMPTE/EBU format to be recorded and played back. This allows editing to single frame precision.

Outputting or inputting timecode (LTC) to or from an external device is also possible using the TIME CODE IN/OUT connectors.

The unit is also compatible with VITC.

High-speed search function

You can carry out a picture search while playing back in color within the range +32 to -32 times normal speed¹⁾.

When controlling the unit in shuttle mode from an editor or remote control unit, you can search at any speed in the range +32 to -32 times normal speed. In jog mode a frame by frame search is possible. During playback in the range +10 to -10 times normal speed, high-speed audio playback is also possible.

Digital slow motion playback

Using the frame memory function, noiseless slow motion playback is possible at any speed in the range $+1/2$ to $-1/2$ times normal speed.

Digital jog sound function

When searching at speeds in the range +1 to $+1/30$ or $-1/30$ to -1 times normal speed, the digital jog sound function is enabled. The audio signal is saved in temporary memory, and replayed according to the search speed. This allows searching on the sound track.

Video process control

For analog video output and SDI-format video output, you can adjust the video output level, chroma signal output level, setup level (for DSR-70A), black level (for DSR-70AP), and chroma phase.

Other Features

Two-Input video recording

With the optional DSBK-180/180P Dual Video Input Board installed, you can record, switching between the composite video input to the VIDEO INPUT connector and the composite video input to the REF. VIDEO IN connector.

The ease of switching video inputs when recording helps improve later editing efficiency.

Menu operations for functions and operating settings

To make it easier to use this unit for any particular purpose, various functions and operating settings are provided in the menu system.

1) The positive direction refers to forward movement of the tape, and the negative direction to reverse movement.

Superimposing function

Timecode, operating mode, error messages, and other text information, can be superimposed on the color liquid crystal display and the analog composite video signal output.

Functions for easy maintenance

- **Self-diagnosis and alarm function:** This automatically detects incorrect operations or connections, operating faults, and so forth, and displays details of the problem, the cause, and the action to be taken, in the color liquid crystal display and the time data display.
- **Digital hours meter:** This keeps four cumulative counts of the powered on time, the drum rotation time, the tape transport time, and the number of tape threadings and unthreadings, and displays them in the color liquid crystal display and the time data display.

Sequential recording

Combining two DSR-70A/70AP units allows you to perform sequential recording from one unit to another. Using two cassettes repeatedly, the last six hours of recording is always available (using 184 minute tapes). When you renew the cassette about every 3 hours, endless recording is possible.

Compatible with wide screen aspect ratio (16:9)

The unit can record and play back aspect ratio information. When video accompanied by wide-screen aspect ratio information is recorded or played back, the unit's LCD monitor automatically switches to 16:9 mode. The video signal output from the unit also contains the aspect ratio information.

AC and DC power

This unit is equipped with V-shoe attachment, on which BP-L60/L60A/L90/L90A or BP-90/90A battery or an AC adaptor can be mounted. The unit can operate for about 120 minutes (with no optional boards installed) with BP-L90 battery mounted. For AC operation, you can connect an AC-550/550CE or AC-DN2A/DN2B adaptor.

Combination of two units

Using the optional BKNW-225 Docking Kit to combine two DSR-70A/70AP units gives you a portable editor.

Compact and lightweight

Even though it is equipped with an LCD monitor and a speaker, the unit weighs only 5.8 kg (12 lb 12 oz). Its compact design makes it easy to carry anywhere.

Options

Optional boards

The optional boards available are as follows.

You can use any and only one of the following boards at the same time.

- **DSBK-140 i.LINK/DV Input/Output Board**

This board enables cut editing between two DSR-70A/70AP units. This board also allows you to connect the unit to other equipment provided with a Sony DV connector to carry out editing or dubbing of digital video and audio signals.

- **DSBK-150 SDTI (QSDI) Input/Output Board**

The unit fitted with this board can be connected to the ES-7 EditStation to carry out digital nonlinear editing. You can also connect the unit to the DSR-85/85P/80/80P/60/60P Digital Videocassette Recorder or Player and carry out digital editing or dubbing operation.

- **DSBK-160A SDI/i.LINK/DV Input/Output Board**

Using this board, you can connect the unit to the DNW-A25/A25P Betacam SX Digital Videocassette Recorder and carry out cut editing. This unit additionally has the function of the DSBK-140 board.

- **DSBK-170 Analog Component Input/Output Board**

This board allows you to connect the unit to Betacam SP VCRs and carry out editing and dubbing operations.

The following board may be used in combination with any one of the above four boards.

- **DSBK-180/180P Dual Video Input Board**

This board allows two video cameras to be connected to the unit so that you may carry out video recording switching between the signals from the two cameras.

BKNW-225 Docking Kit

Use to combine two DSR-70A/70AP units.

System Configuration

The figure below shows example equipment that can be connected to this unit.

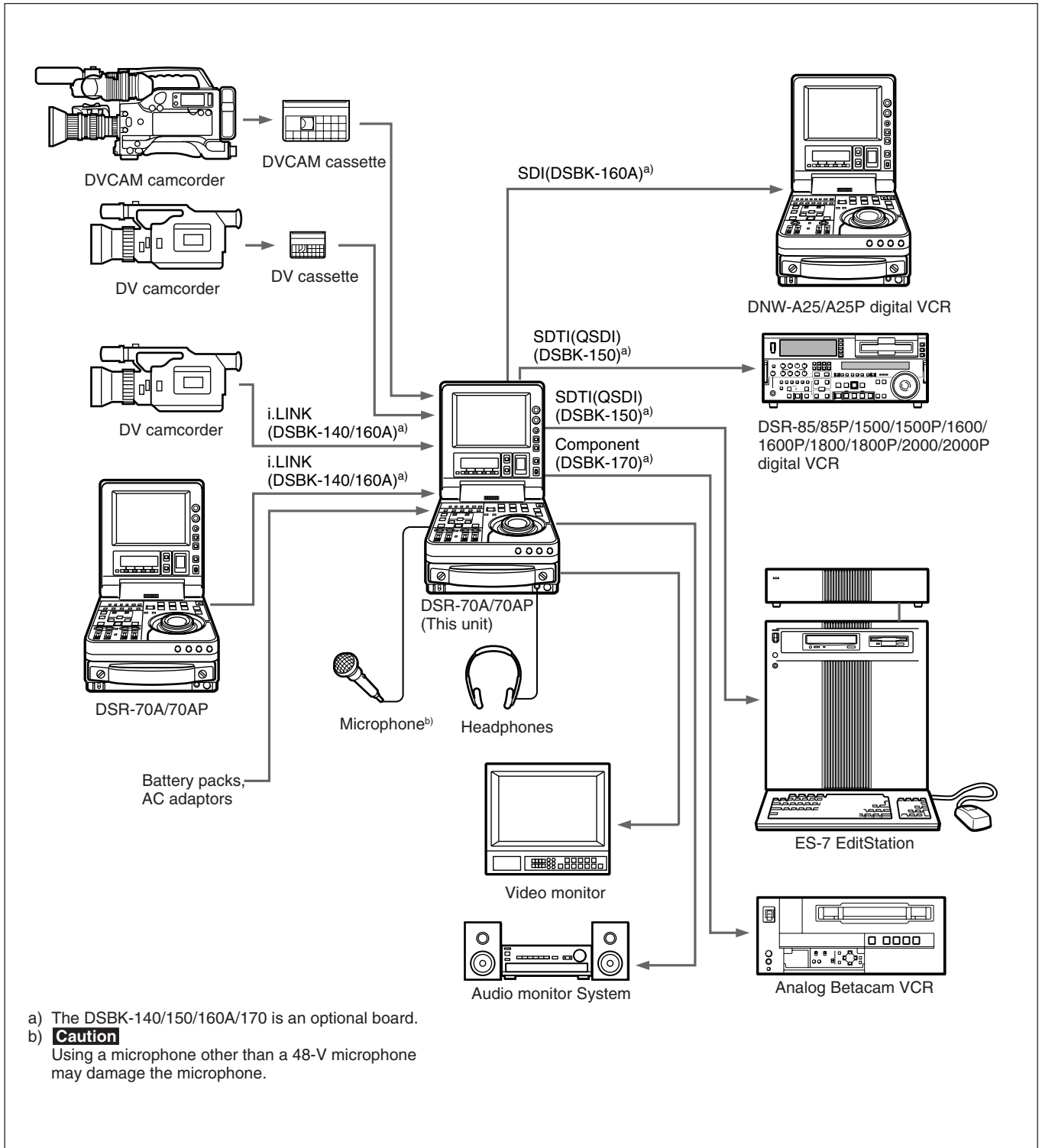

Location and Function of Parts

This unit is comprised of the parts shown in the figure below.

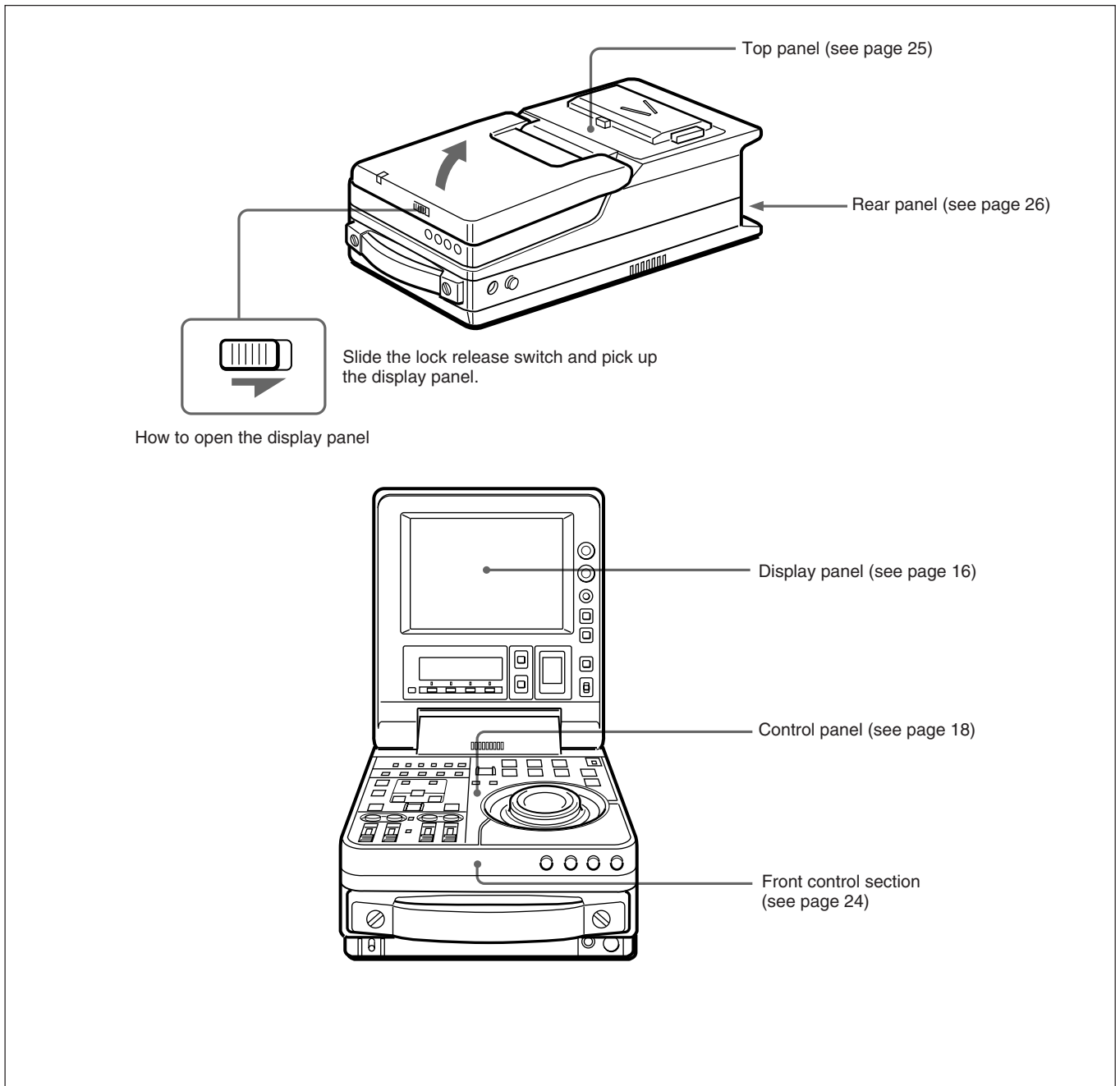

Display Panel

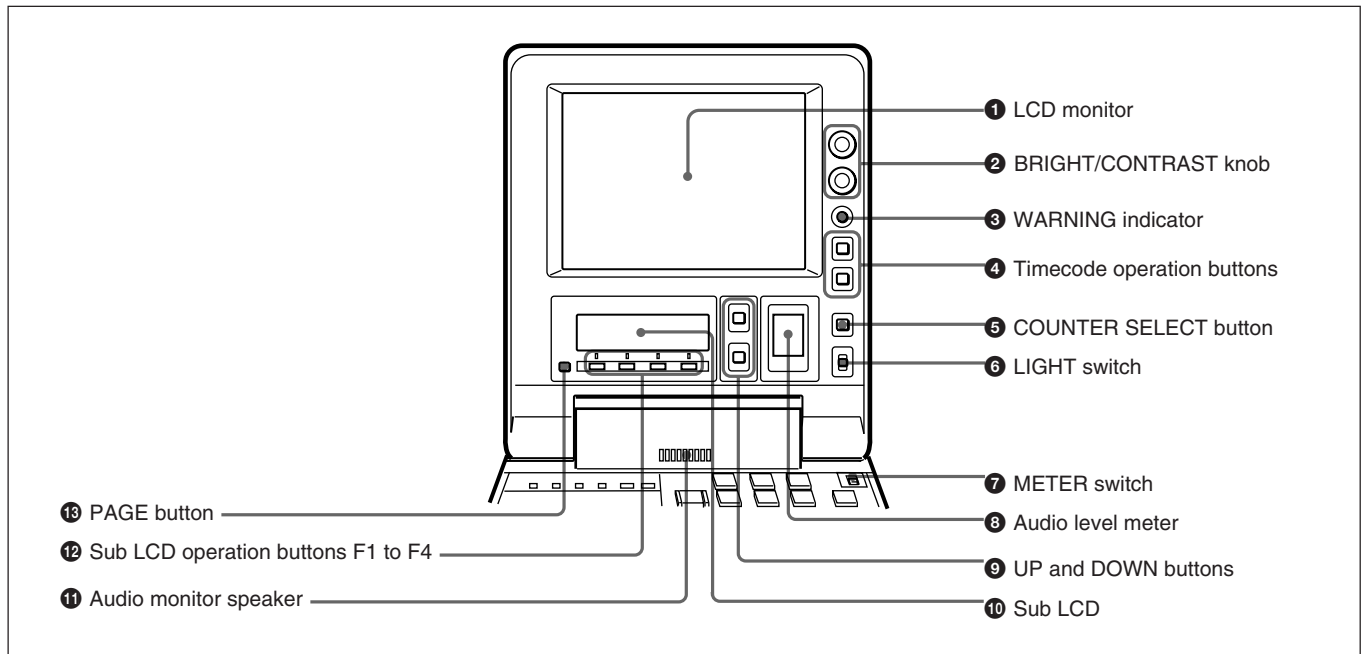

1 LCD monitor

Displays the playback or E-E pictures¹⁾. Time data, status information, and setup menus, etc. are superimposed on the LCD monitor.

2 BRIGHT (brightness)/CONTRAST knob

Adjusts the brightness and contrast of the LCD monitor 1. Adjustments have no effect on the recorded or output video.

3 WARNING indicator

Lights when the battery is exhausted or an error occurs.

It flashes when the end of battery power is near.

4 Timecode operation buttons

HOLD button: Stops the progress of the timecode generator. Press this button before setting timecode or user bits to hold those values.

RESET button: Press this to reset the preset data of CNT (counter value) or TC (timecode) or UB (user bit) indication in the sub LCD 10. Resetting the CNT value erases all edit points that have been set.

Use this button also when resetting the setup menu to its factory default settings.

For more information, see “Setting Time Data” (page 59). For information about how to reset the setup menu to its factory default settings, see “Resetting the menu settings to their factory default values” (page 107).

5 COUNTER SELECT button

Alternately selects CNT (counter value), TC (timecode), and UB (user bits) as the time data used in editing and displayed in the sub LCD 10.

6 LIGHT (backlight on/off) switch

Turns the backlights of the sub LCD 10 and audio level meter 8 on and off.

You can also use the LIGHTSW setting of the sub LCD menu to turn the LCD monitor power on and off. For details, see page 72.

7 METER switch

Selects the audio channel whose level is displayed by the audio level meter 8.

CH-1/2: Display the recording, playback, and E-E levels of audio channels 1 and 2.

CH-3/4: Display the recording, playback, and E-E levels of audio channels 3 and 4.

1) E-E pictures: “E-E” stands for “Electric to Electric.” In E-E mode, the video and audio signals that are input to the VCR’s recording circuitry do not pass through any

magnetic conversion circuits but instead are output via electric circuits only. The pictures output in E-E mode are referred to as E-E pictures.

8 Audio level meter

Displays the recording and playback audio levels of two (CH-1/2 or CH-3/4) of the four audio channels (CH-1 to CH-4), as selected with the METER switch

7.

9 UP and DOWN buttons

Press to make settings in the sub LCD menu.

For more information about the sub LCD menu, see “Sub LCD Menu Home Page and Sub LCD Operation Buttons” (page 64).

10 Sub LCD

Displays time data, status information, remaining battery capacity, remaining tape time, sub LCD menu, setup menu and error messages.

For more information about the sub LCD menu, see “Sub LCD Menu Home Page and Sub LCD Operation Buttons” (page 64).

11 Audio monitor speaker

Plays the mixed audio signal of the audio channels selected with the sub LCD menu item MONITOR. Adjust the volume with the LEVEL knob on the front control panel. You cannot monitor sound from the speaker when headphones are connected to the HEADPHONES jack.

For more information about the MONITOR item, see page 69.

12 Sub LCD operation buttons F1 to F4

Select items in the sub LCD menu.

For more information about the sub LCD menu, see “Sub LCD Menu Home Page and Sub LCD Operation Buttons” (page 64).

13 PAGE button

Switches between pages in the sub LCD menu.

For more information about the sub LCD menu, see “Sub LCD Menu Home Page and Sub LCD Operation Buttons” (page 64).

Location and Function of Parts

Control Panel

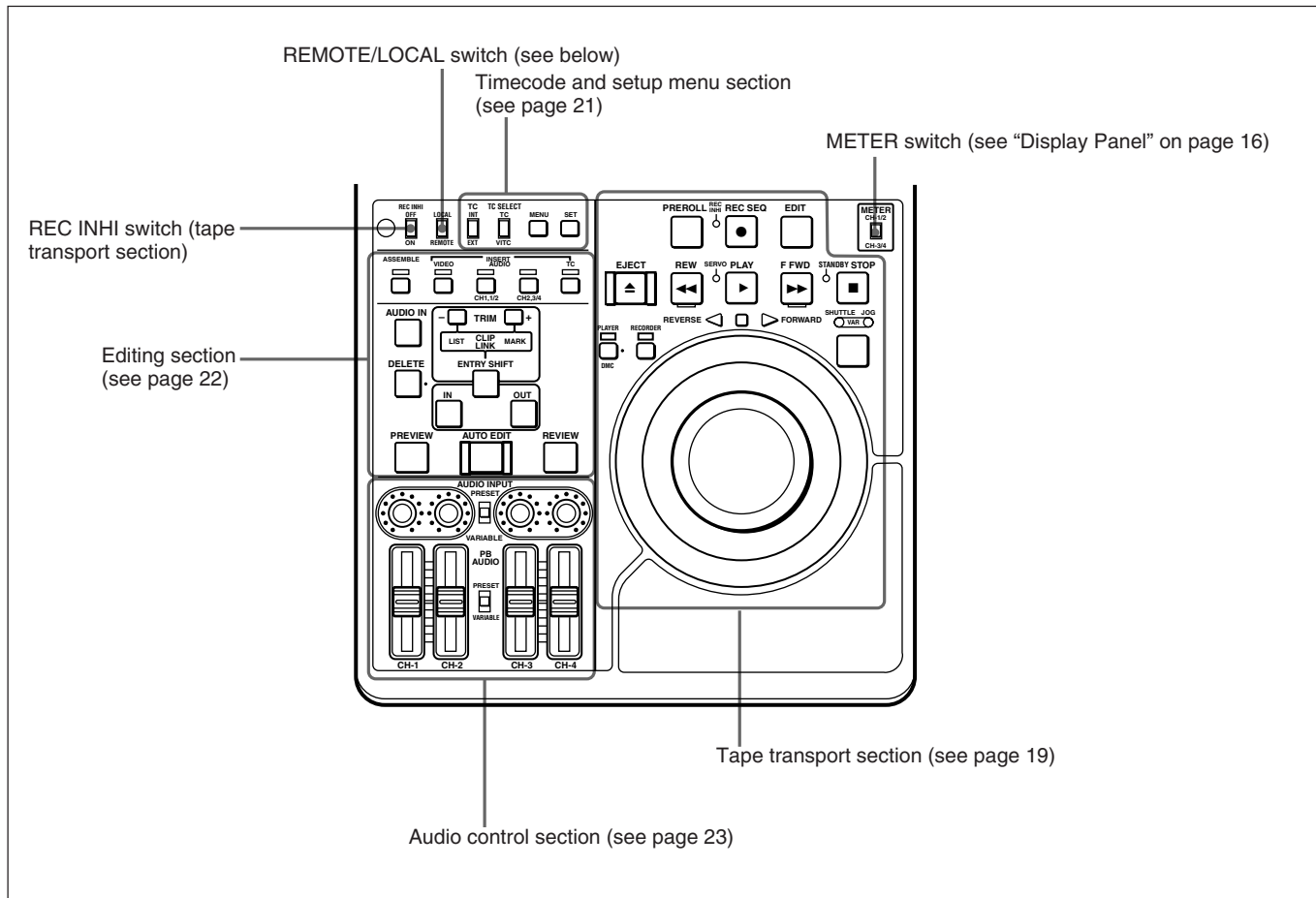

REMOTE/LOCAL switch

Selects the source for control of this unit.

REMOTE: This unit is controlled from the device connected to the REMOTE connector. In this case, all VCR operations using this unit's control panel are disabled except the STOP and EJECT buttons.

When combining two DSR-70A/70AP units as a pair of recorder and player, set the REMOTE/LOCAL switch of the player to REMOTE.

LOCAL: This unit is controlled from the control panel. Normally set the switch to this position.

When the REMOTE is selected, you can determine which tape transport control buttons on the control panel are enabled. See setup menu item 006 (page 104).

Tape transport section

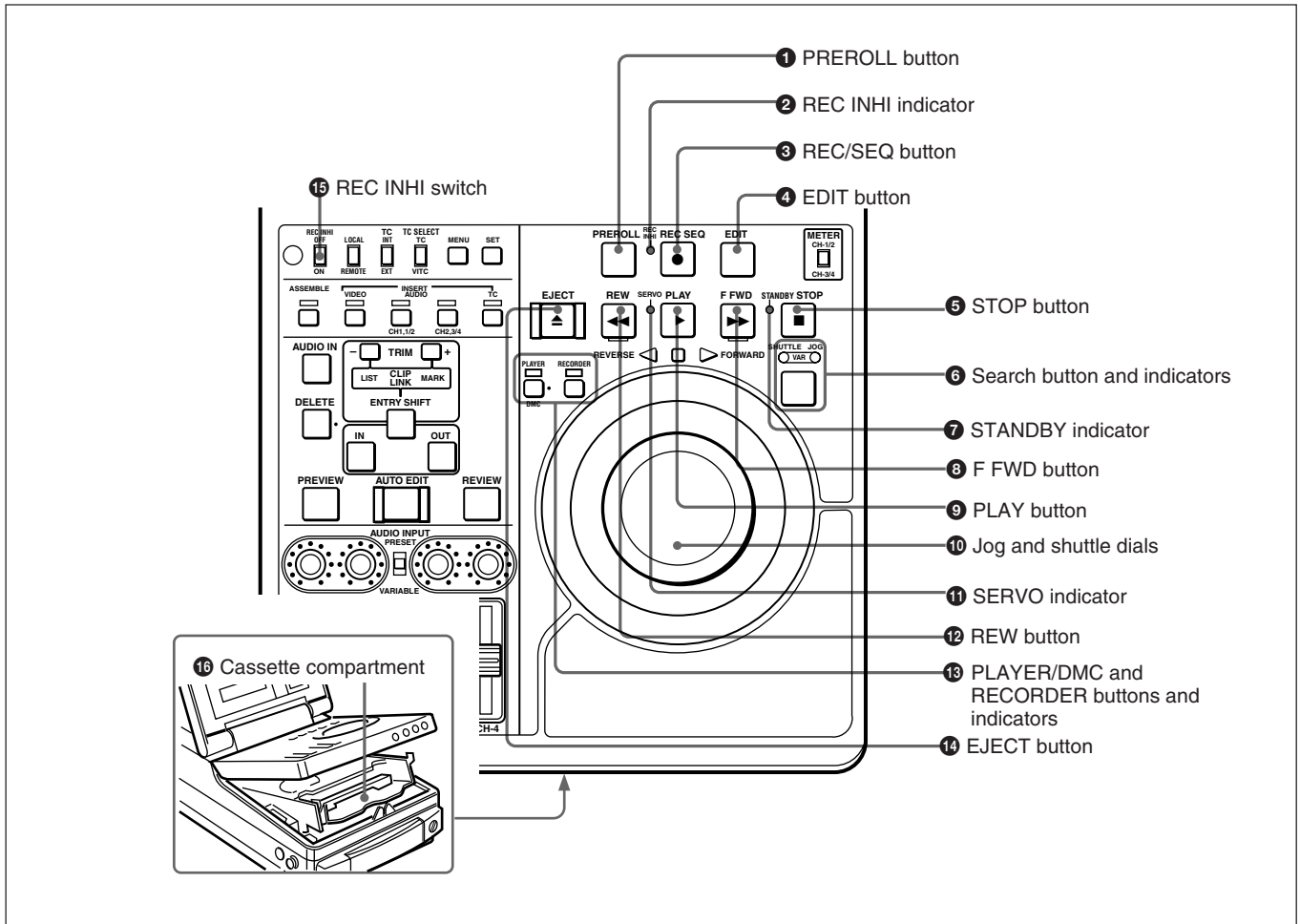

1 PREROLL button

Press to run the tape up to the preroll point (located in advance of the IN point by the amount of the preroll time). You can set the preroll time using setup menu item 001 (page 104). You can set the state of the unit at the end of preroll by using setup menu item 401 (page 112).

By pressing this button at the same time as the IN/OUT or AUDIO IN buttons in the editing section, you can search for a timecode set in advance and stop at that position. (The tape is cued up to the preset timecode position.)

2 REC INHI (recording inhibit) indicator

Lights under the following situations.

- Set the REC INHI switch 15 to ON.
- Set the REC/SAVE switch on the cassette to SAVE.

When the REC INHI switch 15 is in the OFF position, then it is possible to make the REC INHI indicator flash in this state. For details, see setup menu item 107 (page 109).

3 REC/SEQ (recording/sequence) button

Press together with the PLAY button 9 to start recording.

When two DSR-70A/70AP units are combined, this button allows you to perform sequential recording from one unit to another.

For details, see “Sequential Recording Using Two Units” (page 43).

To monitor E-E mode

You can monitor input signals in E-E mode by pressing this button from stop mode. The button lights when pressed. To return to the original picture, press the STOP button 5. You can view E-E video during playback, search, fast forward, and rewind by pressing this button.

The E-E video continues for as long as the button is kept pressed.

Location and Function of Parts

4 EDIT button

Press together with the PLAY button 9 to perform manual editing.

To monitor E-E mode

You can monitor input signals in E-E mode by pressing this button from stop mode. The button lights when pressed, and the input signals selected with the ASSEMBLE or INSERT buttons appear in E-E mode. To return to the original picture, press the STOP button 5. You can view E-E video during playback, search, fast forward, and rewind by pressing this button. The E-E video continues for as long as the button is kept pressed.

5 STOP button

Press this button, lighting it, to stop playback or recording. When you stop playback, the LCD monitor displays E-E or still picture playback, depending on the PB/EE setting in the sub LCD menu. Setting setup menu item 105 to ON or LIMIT causes this button to flash when the input video signal and the reference video signal are asynchronous.

6 Search button and indicators

Press to enter search mode. (The JOG or SHUTTLE indicator lights.)

When the unit is in jog or shuttle mode, keep this button pressed for about 1 second to enter variable speed mode. (The both indicators light.) To return to shuttle mode, keep this button pressed again for about 1 second.

In shuttle or variable speed mode, you can start playback at preset speed by rotating the shuttle dial to the desired position and pressing this button.

When setup menu item 128 is set to ON, this button functions as a pause button. You can use the pause button to make a pause during sequential recording carried out using two DSR-70A/70AP units.

7 STANDBY indicator

Lights when the tape drum is rotating with tension applied (standby on). It goes out when the drum stops rotating and tension is released (standby off).

To protect the tape, the unit normally changes to standby off when stop mode continues for longer than 1 minute. If you operate a dial or any of the tape transport buttons except STOP 5 while the unit is in this state, the unit changes to standby on and enters the mode of the button or dial that you pressed.

Press the ENTRY/SHIFT button and STOP button 5 at the same time to switch between standby on and standby off manually.

For more information about tape protection, see the setup menu items in the 500s (page 112).

8 F FWD (fast forward) button

Press this button, lighting it, to fast forward the tape. By pressing the TRIM+/MARK button and this button simultaneously, you can cue up to any Mark IN point or cue point provided by ClipLink log data.

For details, see Chapter 6 “ClipLink Operation” (page 93).

9 PLAY button

Press this button, lighting it, to start playback. Recording starts when you press this button together with the REC/SEQ button 3, and manual editing starts when you press this button together with the EDIT button. If you press this button only during recording or manual editing, recording or manual editing stops and the unit returns to playback mode.

10 Jog and shuttle dials

To search in shuttle mode, rotate the outer ring (shuttle dial). To search in shuttle or variable speed mode, press the inner ring (jog dial) until it clicks and then rotate. Rotate in the clockwise direction to search in the forward direction (the FORWARD indicator lights), and rotate in the counterclockwise direction to search in the reverse direction (the REVERSE indicator lights).

For more information about search, see “Finding Edit Points — Search” (page 79).

11 SERVO indicator

Lights when the drum and capstan are servo-locked.

12 REW (rewind) button

Press this button, lighting it, to rewind the tape. Alternatively, by pressing the TRIM+/MARK button and this button simultaneously, you can cue up to any Mark IN point or cue point provided by ClipLink log data.

For details, see Chapter 6 “ClipLink Operation” (page 93).

13 PLAYER/DMC and RECORDER buttons/indicators

Press to control a player connected to the REMOTE (9-pin) connector or DV connector (when DSBK-140/160A is installed) by remote control (the indicator lights).

PLAYER/DMC button: The buttons of the editing and tape transport sections on the recorder side of the control panel work to control the remote player.

You can also press this button together with the ENTRY/SHIFT button to put the unit into DMC edit mode.

For details, see “DMC Editing” (page 87).

RECORDER button: The buttons of the editing and tape transport sections on the recorder side of the control panel work to control the recorder itself.

14 EJECT button

Press to eject the cassette or open the cassette compartment 16. The button lights while the cassette is being ejected.

15 REC INHI switch

When on, recording to the tape is inhibited, regardless of the setting of the cassette’s REC/SAVE switch. (The REC INHI indicator 2 lights.)

16 Cassette compartment

Insert a cassette here. Press the EJECT button 14 to open the compartment.

Timecode and setup menu section

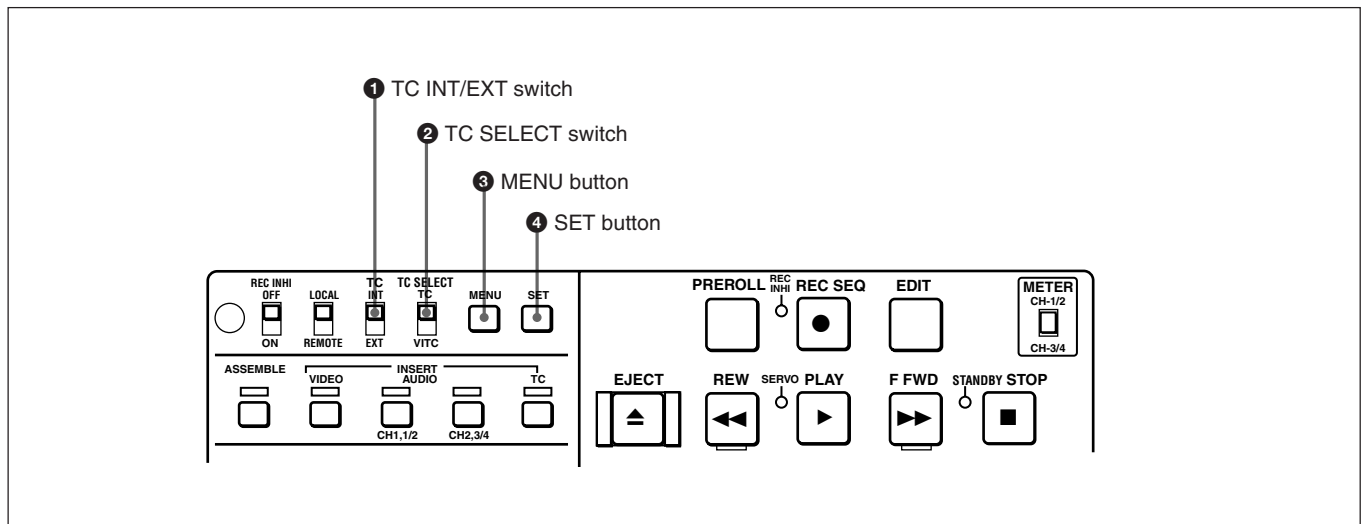

1 TC INT/EXT (internal/external timecode) switch

Selects the timecode to use.

INT: Use the timecode generated by this unit’s built-in timecode generator.

EXT: The external time code selected as follows.

- When the TC SELECT switch is set to TC
The external time code input to the TIME CODE IN connector
- When the TC SELECT switch is set to VITC
The VITC time code included in the input video signal

2 TC (time code) SELECT switch

This switch selects the time code, TC or VITC, shown in the time data display.

3 MENU button

Use for setup menu operations. The setup menu appears on the LCD monitor when you press this button, and the original display appears when you press it again.

For more information about setup menu operations, see Chapter 7 “Setup Menu” (page 103).

Location and Function of Parts

4 SET button

Use to make setup menu settings, timecode settings, and user bit settings.

For more information about setup menu operations, see Chapter 7 “Setup Menu” (page 103). For more information about timecode and user bit settings, see “Setting Time Data” (page 59).

Editing section

Use two DSR-70A/70AP units or one DSR-70A/70AP unit and an editing player for editing.

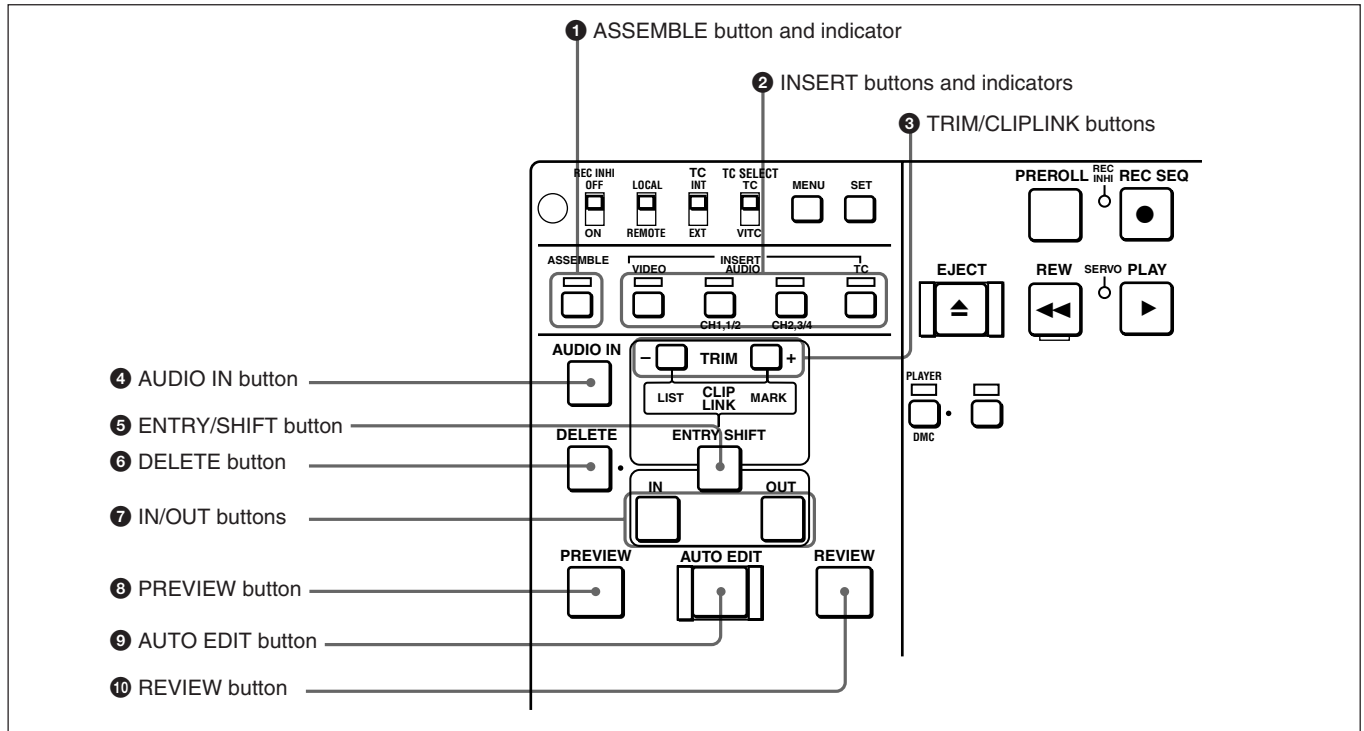

1 ASSEMBLE button and indicator

Press this button, lighting the indicator, to carry out assemble editing. Press the button again, turning the indicator off, to leave assemble edit mode.

2 INSERT buttons and indicators

Press these buttons, turning the indicators on, to select signals for insert editing. Press the buttons again, turning the indicators off, to cancel the selection.

VIDEO button: Selects the video signal.

AUDIO “CH1, 1/2 button and AUDIO “CH2, 3/4” button: When the AUDIO recording mode is 2 channel/48 kHz these select CH-1 (channel 1) or CH-2.

When the AUDIO recording mode is 4 channel/32 kHz, these select CH-1 and CH-2 (channels 1 and 2) or CH-3 and CH-4.

In this case it is not possible to select channels 1 to 4 individually.

TC button: Selects the timecode signal.

3 TRIM/CLIPLINK buttons

Press the +/MARK or -/LIST buttons while pressing the IN/OUT buttons 7 or AUDIO IN button 4 to adjust edit points in unit of 1 frame. The +/MARK button advances 1 frame, and the -/LIST button returns 1 frame.

By pressing the TRIM+/MARK button and the F FWD or REW button simultaneously, you can cue up to any Mark IN point or cue point provided by ClipLink log data.

For details, see Chapter 6 “ClipLink Operation” (page 93).

During two-camera switched recording carried out using the optional DSBK-180/180P board, you can switch between the composite video signals from the two video cameras by pressing the +/MARK button and the -/LIST button at the same time.

For more information about two-camera switched recording, see “Two-Input Switched Video Recording” (page 46).

4 AUDIO IN button

In insert editing, press this button together with the ENTRY/SHIFT button 5 to set audio IN point separately from video IN point (audio split editing). After setting audio IN points, you can press this button alone to display them in the sub LCD.

5 ENTRY/SHIFT button

Press together with the IN button, OUT button 7, or AUDIO IN button 4 to set edit points. The buttons for the edit points that you set light. Pressing this button together with a button with two functions, such as the PLAYER/DMC button or REC/SEQ button, selects the function indicated in orange on the button.

6 DELETE button

Press together with the IN/OUT buttons 7 or the AUDIO IN button 4 to delete edit points. The buttons go out or flash. A flashing button indicates that the edit point needs to be set again.

The DELETE button flashes to indicate contradictions that will prevent previews and automatic editing, for example when the durations are different on the player and recorder, or when the IN and OUT points are equal or reversed. In this case, set the edit points again.

7 IN/OUT (IN point/OUT point) buttons

Press these buttons, lighting them, together with the ENTRY/SHIFT button 5 to set an IN point (edit start point) or OUT point (end point). After setting edit points, you can press either of these buttons alone to display the IN or OUT point in the sub LCD.

8 PREVIEW button

Press this button, lighting it, when you want to preview editing results on the monitor after setting edit points but before executing an edit or to set the player playback speed for DMC editing. If an IN point has not been set, the point where you press this button is used as the IN point in the preview. This button lights during the preview and goes out when the preview finishes.

9 AUTO EDIT button

After setting edit points, press this button, lighting it to execute an automatic edit (record to the recorder). If an IN point has not been set, the point where you press this button is used as the IN point in the automatic edit. This button lights during execution and goes out when execution finishes. Pressing this button when the unit is in DMC edit mode executes a DMC edit.

To conduct DMC editing, a playback speed must be set in advance. For details, see “DMC Editing” (page 87).

10 REVIEW button

After executing an automatic edit, press this button, lighting it to review the results of the edit.

Audio control section

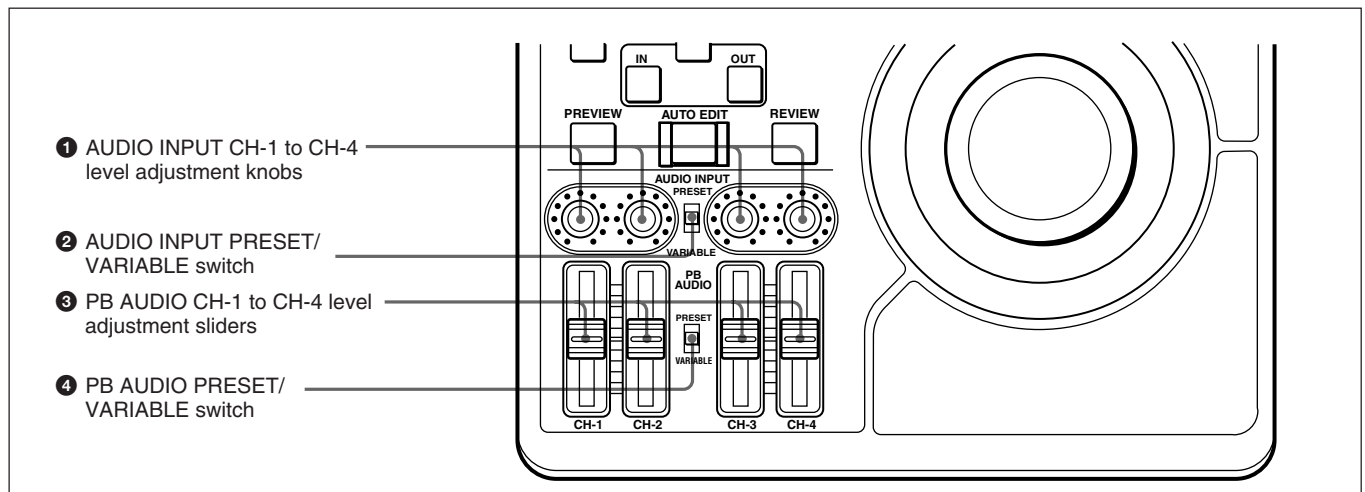

Location and Function of Parts

1 AUDIO INPUT CH-1 to CH-4 level adjustment knobs

Adjust the levels for each channel of analog audio signals input to the AUDIO INPUT CH-1/CH-2 connectors on the rear panel, or of the audio signals input to the SDI, SDTI(QSDI), and DV IN/OUT connectors of the optional boards.

2 AUDIO INPUT PRESET/VARIABLE switch

Select the adjustment function for the levels of analog audio signals input to the AUDIO INPUT CH-1/CH-2 connectors on the rear panel, or of the audio signals input to the SDI, SDTI(QSDI), and DV IN/OUT connectors of the optional boards.

PRESET: Preset to fixed levels. Levels cannot be adjusted with the level adjustment knobs.

VARIABLE: Levels adjustable with level adjustment knobs. This allows you to adjust the levels while viewing the audio level meters in E-E mode.

descriptions of the REC/SEQ and EDIT buttons (pages 19 and 20)

3 PB AUDIO CH-1 to CH-4 level adjustment sliders

Make level adjustments by channel for playback audio channels 1 to 4. You cannot adjust the levels of audio signals output to the SDTI(QSDI) OUT connector or DV IN/OUT connector attached to an optional board (DSBK-140/150/160A).

4 PB AUDIO PRESET/VARIABLE switch

Selects the level adjustment function for playback audio.

PRESET: Preset to fixed levels. Levels cannot be adjusted with the level adjustment sliders.

VARIABLE: Levels adjustable with the level adjustment sliders. This allows you to adjust the levels while viewing the audio level meter.

Front Control Section

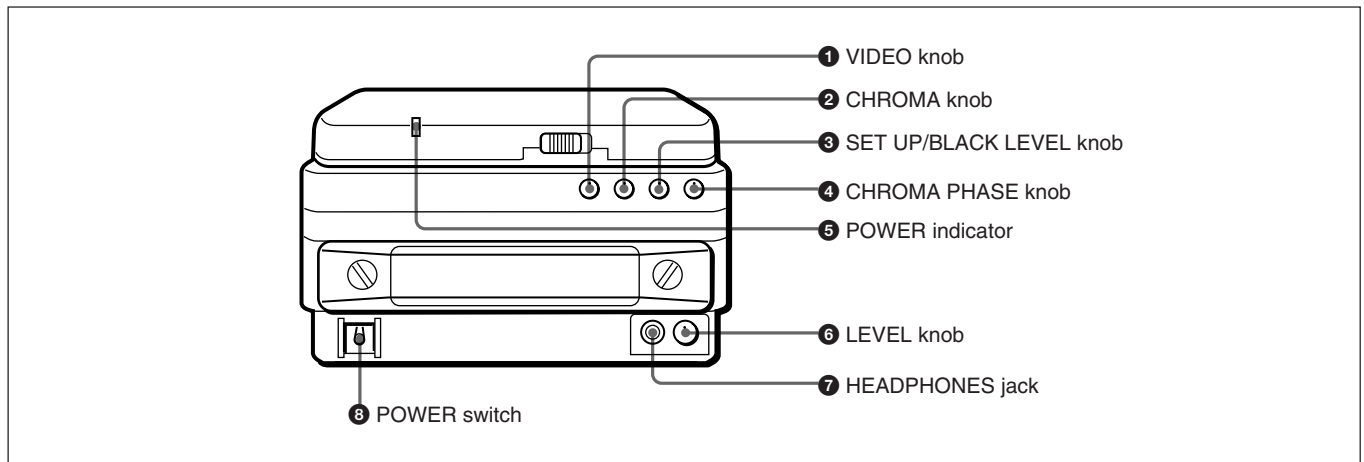

1 VIDEO knob

Adjusts the video signal output level. This knob is a push switch. When you press it to bring it into the raised position, the setting becomes VARIABLE. When you press it again to depress it, the setting returns to PRESET.

PRESET: This is the normal setting. Regardless of the knob position, the video signal output level is set to the standard value.

VARIABLE: The video signal output level can be adjusted across a range of ± 3 dB.

2 CHROMA knob

Adjusts the chroma signal output level. This knob is a push switch. When you press it to bring it into the raised position, the setting becomes VARIABLE. When you press it again to depress it, the setting returns to PRESET.

PRESET: This is the normal setting. Regardless of the knob position, the chroma signal output level is set to the standard value.

VARIABLE: The chroma signal output level can be adjusted across a range of ± 3 dB.

You can change the adjustment range by using setup menu item 714. For details, see page 114.

You can change the adjustment range by using setup menu item 714. For details, see page 114.

3 SET UP/BLACK LEVEL knob

Adjusts the setup level (for DSR-70A) or the black level (for DSR-70AP). This knob is a push switch. When you press it to bring it into the raised position, the setting becomes VARIABLE. When you press it again to depress it, the setting returns to PRESET.

PRESET: This is the normal setting. Regardless of the knob position, the setup level (for DSR-70A) or the black level (for DSR-70AP) is set to the standard value.

VARIABLE: The setup level can be adjusted across a range of ± 30 IRE (for DSR-70A) and the black level can be adjusted across a range of ± 210 mV (for DSR-70AP).

4 CHROMA PHASE knob

Adjusts the chroma phase (phase relative to burst). This knob is a push switch. When you press it to bring it into the raised position, the setting becomes VARIABLE. When you press it again to depress it, the setting returns to PRESET.

PRESET: This is the normal setting. Regardless of the knob position, the chroma phase is set to the standard value.

VARIABLE: The chroma phase can be adjusted across a range of $\pm 30^\circ$.

5 POWER indicator

Lights green when the POWER switch **8** is turned on, and changes to red when recording starts.

6 LEVEL (speaker/headphones level) knob

Adjusts the volume of the speaker or headphones connected to the HEADPHONES jack **7**.

7 HEADPHONES jack (stereo phone jack)

Connect headphones. The speaker is muted when headphones are connected.

8 POWER switch

Powers the unit on and off. When the unit is powered, the POWER indicator **5** lights.

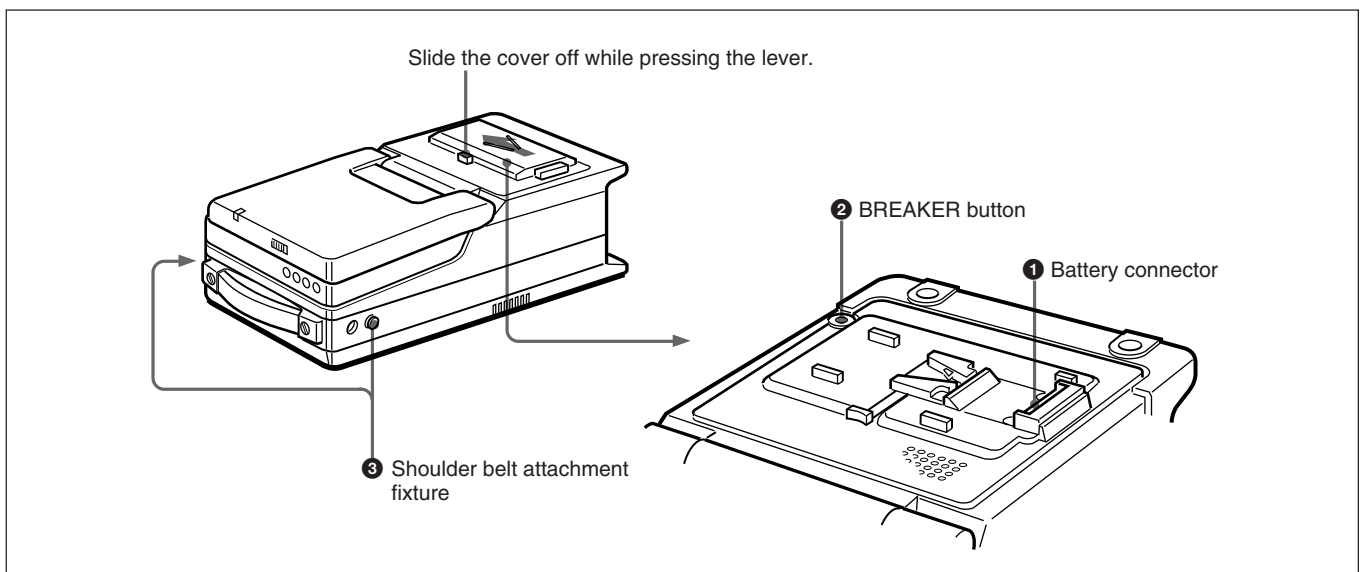
Top Panel**1 Battery connector**

Connect a BP-L60/L60A/L90/L90A Battery Pack, DC-L90 Battery Adaptor, or AC-DN2A/DN2B AC Adaptor.

When the AC-550/550CE AC Adaptor or another power supply has been connected to the DC IN connector on the rear panel, the power from the DC IN connector is used instead of the power from this connector.

For more information, see "Power Preparations" (page 31).

Note

The AC-DN1 AC Adaptor and the BP-L40 and NP-1B Battery Packs cannot be used.

Location and Function of Parts

2 BREAKER button

When excess power flows inside the unit, the breaker activates to protect the circuits by automatically shutting down the power. After inspecting and adjusting the unit, press this button. If there is no further trouble, the power will be restored.

For inspection and adjustment of the unit, consult your Sony dealer.

3 Shoulder belt attachment fixture

Attach the supplied shoulder belt.

For more information, see “Using the Shoulder Belt” (page 133).

Rear Panel

Analog audio/video input and output section

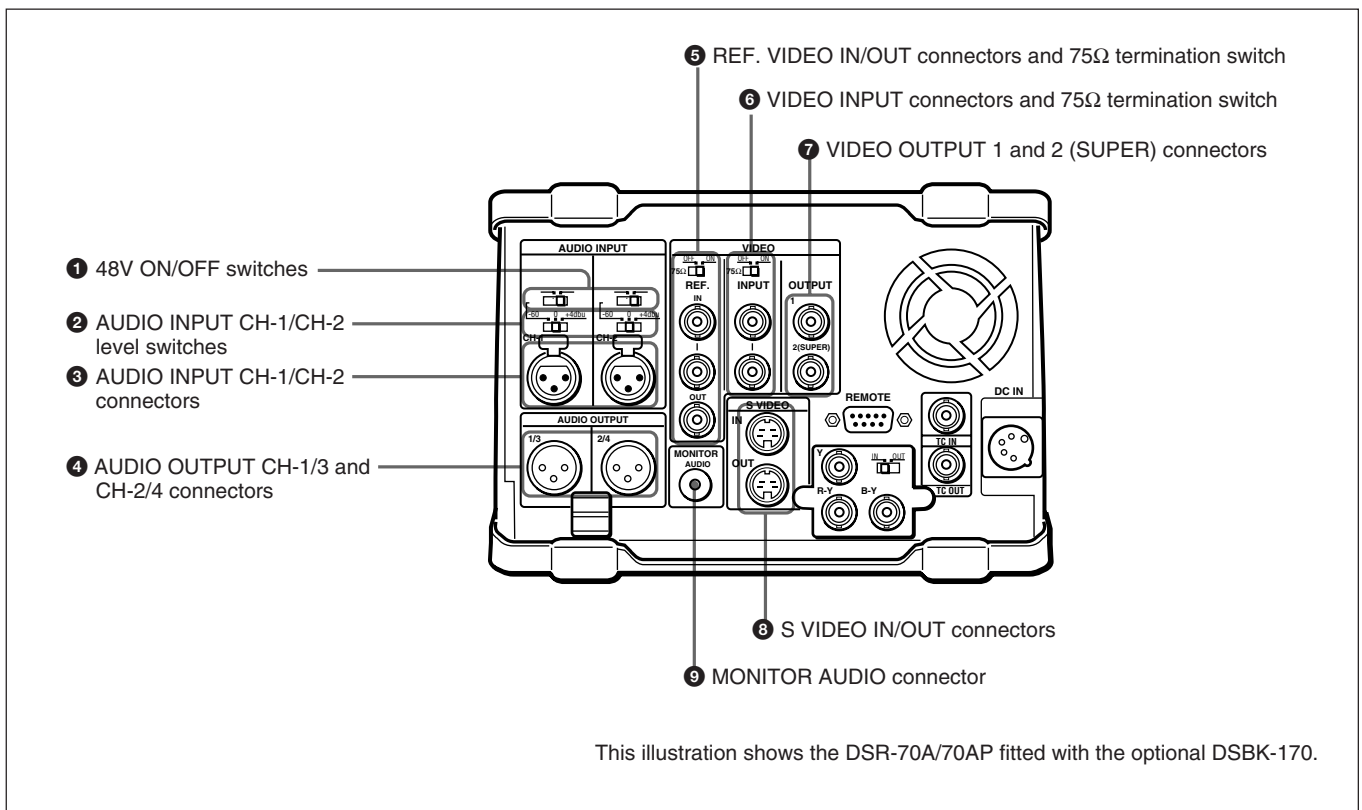

1 48V ON/OFF switches

When the AUDIO INPUT CH-1/CH-2 level switches are set to -60 dBu, setting these switches to ON causes 48-V power to be supplied to the AUDIO INPUT connectors.

2 AUDIO INPUT CH-1/CH-2 level switches

Select the input level of the analog audio signals of input channels 1 and 2.

-60 dBu: Microphone input

0 dBu: Line audio input

$+4$ dBu: Line audio input (0 dBu = 0.775 Vrms)

For microphone inputs, use 48-V microphones, and set the AUDIO INPUT CH-1/CH-2 level switches 2 to -60 dBu and the 48V ON/OFF switches 1 to ON, respectively.

Caution

Using a microphone other than a 48-V microphone may damage the microphone.

③ AUDIO INPUT CH-1/CH-2 connectors (XLR 3-pin, female)

Input the analog audio signals of input channels 1 and 2.

④ AUDIO OUTPUT CH-1/3 and CH-2/4 connectors (XLR 3-pin, male)

Output the audio signals of the channels selected with the sub LCD menu item LINE OUT. You can select two combinations of output signals: channels 1 and 2, or channels 3 and 4.

For more information about LINE OUT settings, see page 69.

Note

The level can be adjusted from the control panel, but mixed signals cannot be output.

⑤ REF. VIDEO IN/OUT (reference video signal input/output) connectors (BNC type) and 75Ω termination switch

When using an external reference video signal, input it to one of the REF. VIDEO IN connectors. Set the 75Ω termination switch to OFF when the signal is bridged, and to ON when the signal is not bridged.

The REF. VIDEO OUT connector outputs a reference video signal.

⑥ VIDEO INPUT (analog composite video input) connectors (BNC type) and 75Ω termination switch

Input an analog composite video signal. Set the 75Ω termination switch to OFF when the signal is bridged, and to ON when the signal is not bridged.

⑦ VIDEO OUTPUT (analog composite video output) 1 and 2 (SUPER) connectors (BNC type)

Output analog composite video signals. When the sub LCD menu item CHARACTER is set to ON, timecode, menu settings, error messages and other information is superimposed on the output of 2 (SUPER) connector.

For details about the superimposed information, see page 59.

⑧ S VIDEO IN/OUT connectors (4-pin)

Input an S-video signal with separated Y (luminance) and C (chroma: 3.58 MHz for DSR-70A and 4.43 MHz for DSR-70AP) components to the S VIDEO IN connector.

The S VIDEO OUT connector outputs an S-video signal.

⑨ MONITOR AUDIO connector (phono jack)

Output the audio signals of the channels selected with the sub LCD menu item MONITOR. The level is adjustable, and mixing is possible.

For more information about the MONITOR item, see page 69.

Location and Function of Parts

Optional board/timecode/remote control/power input and output section

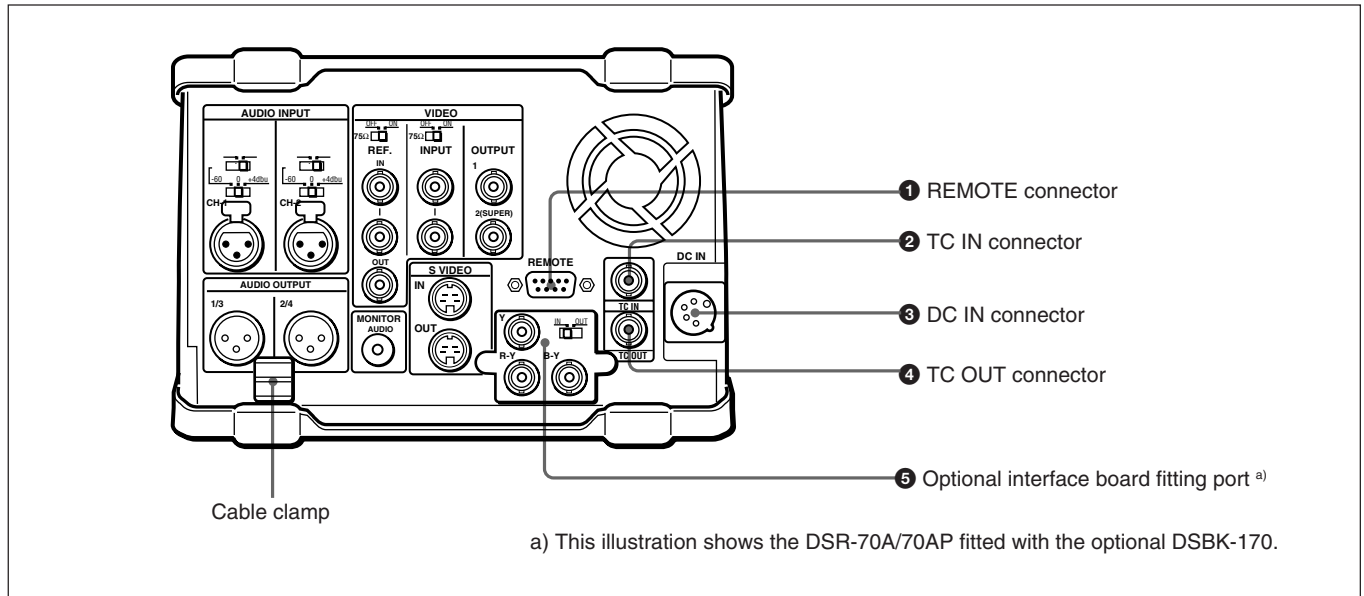

1 REMOTE (9-pin remote control) connector (D-sub 9-pin)

When editing with two DSR-70A/70AP units, connect this connector on each unit using a 9-pin remote control cable (not supplied). When editing with this unit and external equipment, connect the external equipment.

2 TC IN (timecode input) connector (BNC type)

To record timecode from an external device, input the timecode from the external device's timecode output connector.

3 DC IN (external power input) connector (XLR 4-pin, male)

To power this unit with AC power, connect to the DC output connector of the AC-550/550CE AC adaptor. You can also connect a BP-90/90A Battery Pack using the DC-210 Battery Adaptor.

Power supplied through this connector is used on a priority basis even when you have connected a battery pack or AC-DN2A/DN2B AC Adaptor to the battery connector on the top panel.

For more information, see "Power Preparations" (page 31).

4 TC OUT (timecode output) connector (BNC type)

Outputs the following types of timecode, depending on the VCR operating status.

During playback: The playback timecode

During recording: The timecode generated by the internal timecode generator, or the timecode input through the TC IN connector.

For details of the timecode output during recording, see setup menu item 611 (page 114).

5 Optional interface board fitting port

Install any one of the following optional interface boards here:

- DSBK-140 i.LINK/DV Input/Output Board
- DSBK-150 SDTI (QSDI) Input/Output Board
- DSBK-160A SDI/i.LINK/DV Input/Output Board
- DSBK-170 Analog Component Input/Output Board

The connectors provided by the optional boards are as follows.

Connector of the DSBK-140

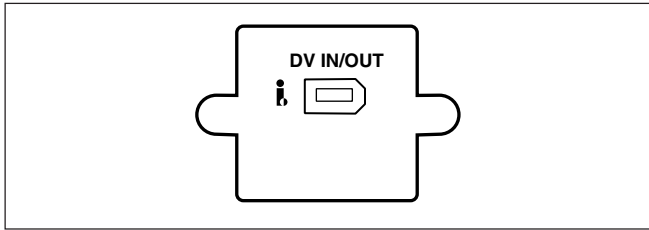

i DV IN/OUT (DV input/output) connector (6-pin IEEE1394 connector): This connector is i.LINK compatible. Connect to another DSR-70A/70AP unit or a consumer DV camera to carry out such operations as recording and editing.

Connectors of the DSBK-150

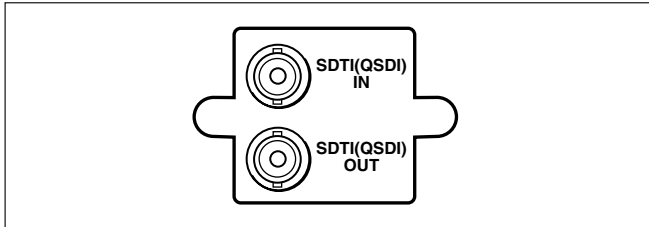

SDTI(QSDI) IN/OUT (input/output) connectors (BNC type): Use to input/output digital video/audio signals in SDTI(QSDI) format.

Connectors of the DSBK-160A

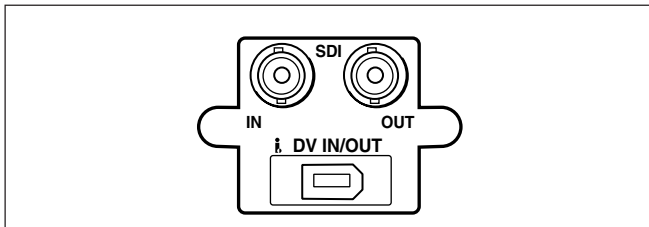

SDI IN/OUT (serial digital interface signal input/output) connectors (BNC type): Use to input/output digital video/audio signals in SDI (D1) format.

i DV IN/OUT (DV input/output) connector (6-pin IEEE1394 connector): This connector is i.LINK compatible. Connect to another DSR-70A/70AP unit or a consumer DV camera to carry out such operations as recording and editing.

Connectors of the DSBK-170

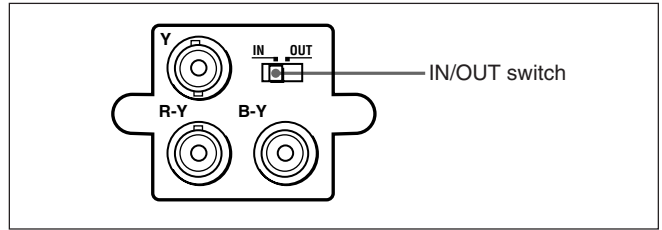

Y, R-Y, B-Y (luminance and color difference signal) input/output connectors (BNC type): Use to input or output analog component signals (Y, R-Y, B-Y). When using as input connectors, set the IN/OUT switch to IN. When using as output connectors, set the IN/OUT switch to OUT.

Power Preparations

Power Preparations

This unit can be powered by batteries or AC power.
Example battery packs and AC adaptors that can be used are shown below.

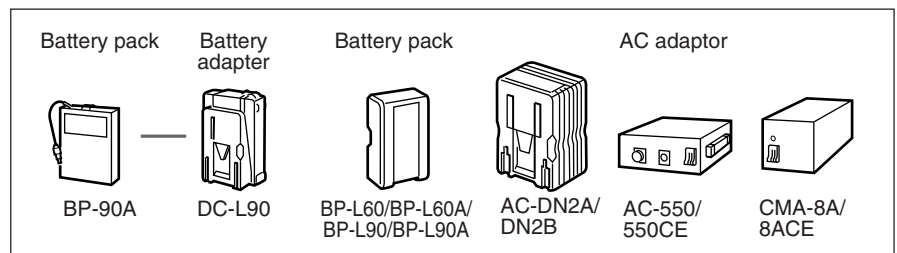

Note

If you attach or remove batteries or AC adaptors incorrectly, they may fall down and cause body injury.

Follow the procedures described below to attach or remove them.

Usable Batteries

Batteries that can be used with this unit are as follows. For each type of battery, a special battery adaptor and battery charger is required.

Battery	Battery Adaptor	Battery Charger
BP-90/90A (mounted on this unit)	DC-L90	BC-210/210CE/ 410/410CE
BP-90/90A (connected to DC IN connector)	DC-210	BC-210/210CE/ 410/410CE
BP-L60/L60A/L90/L90A	Not needed	BC-L120/L100/ L100CE/L50

In the subsequent pages, the batteries such as the BP-90/90A and BP-L60/L60A will also be referred to as the BP-90(A) and BP-L60(A).

Notes about battery usage

- Before using the batteries, be sure to charge them fully with the special battery charger. Refer to the operating instructions of your battery charger for more information about how to charge the batteries.
- Batteries may not be completely charged if you charge them immediately after use when they are still warm. You should wait until the batteries cool before charging them.

Using the BP-L60(A)/L90(A) Battery Pack

This unit can be operated for about 120 minutes at normal temperature on fully charged BP-L90 Battery Pack. (When no optional board is installed.)

To charge the battery pack

Before use, charge the battery pack with the BC-L100/L100CE Battery Charger. It takes about 2.5 hours to charge the BP-L60(A) and about 3.5 hours to charge the BP-L90(A).

For more information about how to charge the battery pack, refer to the manual for the BC-L100/L100CE.

To attach the battery pack

Attach the BP-L60(A)/L90(A) as shown in the following figure. Before attaching, remove the cover of the battery connector.

Remove the cover in the same way that you remove the battery pack. For details see the next section “To remove the battery pack.”

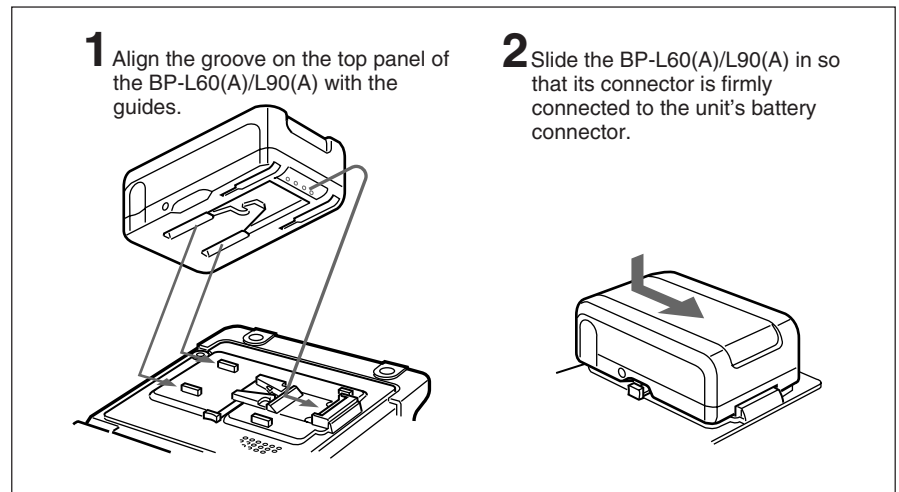

To remove the battery pack

With the lever pushed in, slide the BP-L60(A)/L90(A) out.

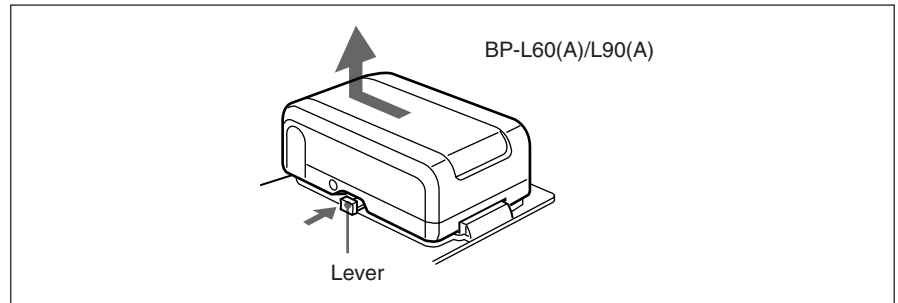

Using the BP-90(A) Battery Pack

Different battery adaptors are used when mounting the BP-90(A) on the top panel of this unit and when connecting it the DC IN connector. This unit can be operated for about 70 minutes at normal temperature on a fully charged BP-90(A) Battery Pack. (When no optional board is installed.)

To charge the battery pack

Before use, be sure to charge the battery pack with the BC-210/210CE/410/410CE Battery Charger. It takes about 2 hours to charge the BP-90(A).

For more information about how to charge the battery pack, refer to the manual for the BC-210/210CE/410/410CE.

To attach to the top panel of this unit

Use the DC-L90 Battery Adaptor.

1 Mount the BP-90(A) in the DC-L90.

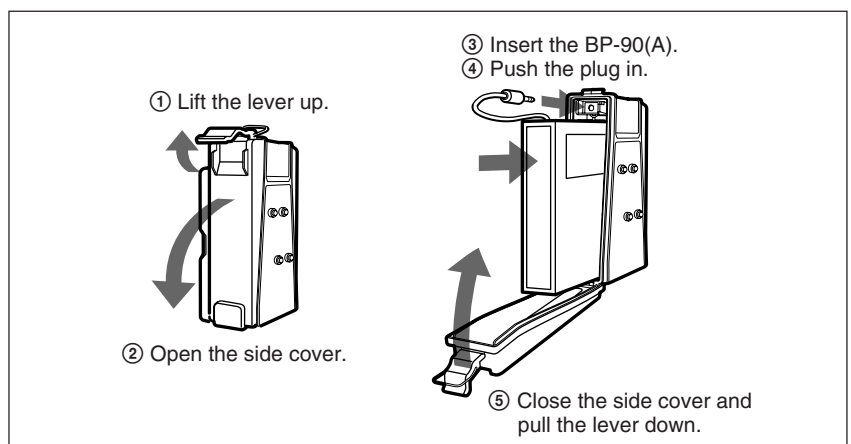

(Continued)

2 Attach the DC-L90 to the top panel of this unit.

Use the same method that you use to attach the BP-L60(A)/L90(A).
For details, see “To attach the battery pack” (page 32).

To connect to the DC IN connector

Use the DC-210 Battery Adaptor.

For more information about connections, refer to the operating instructions of the DC-210.

You can also connect another battery pack to the DC IN connector when a BP-90(A) battery pack is already mounted on the top panel of this unit. When you connect an external battery pack to the DC IN connector, the power supply automatically switches to the external battery pack from an internal battery pack mounted on the top panel of the unit.

Notes

- Noise may occur in video and audio signals at the moment when the unit switches from the internal to the external battery.
- It is always the external battery connected to the DC IN connector that serves as power supply. You cannot switch the power supply from the external battery to the internal battery while the external battery is connected to the DC IN connector.

When an external battery pack is almost exhausted

If an internal battery pack is already mounted, disconnect the external battery pack by pulling its DC power cord out from the DC IN connector. If no internal battery pack is mounted, disconnect the external battery pack after mounting a fully charged internal battery pack.

When an internal battery pack is almost exhausted

For the remaining battery power indication (*see page 65*), the “BATT” display flashes.

Connect a fully charged external battery pack to the DC IN connector, then exchange the internal battery pack.

Using AC Power

You can operate the unit from an AC power source by using the AC-550/550CE AC Adaptor or AC-DN2A/DN2B AC Adaptor.

Use the AC-550/550CE to connect the AC power source to the DC IN connector, and the AC-DN2A/DN2B to connect the AC power source to the battery connector.

To use the AC-550/550CE

As shown in the following figure, connect the AC-550/550CE to the AC power source and turn it on.

When you connect AC power, the power supply automatically switches to the AC power from a battery pack mounted on the top panel of the unit.

Note

Noise may occur in video and audio signals at the moment when the unit switches from the battery pack to AC power.

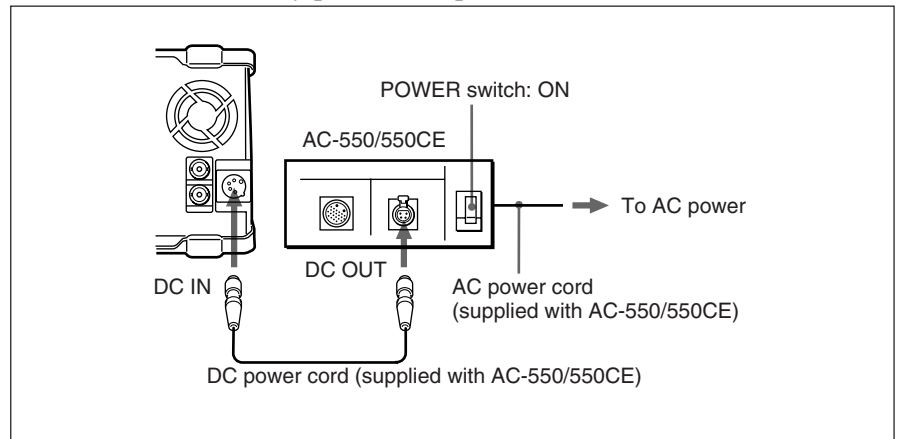

To use the AC-DN2A/DN2B

Follow the procedure below to mount the AC-DN2A/DN2B on the top panel of this unit, and connect to AC power.

When two DSR-70A/70AP units are combined, you can supply both units with power by fitting a single AC-DN2A/DN2B to either unit.

Caution

When you use a single AC-DN2A/DN2B to supply power to two DSR-70A/70AP units, exercise the following caution:

- Do not turn the POWER switches of both units on at a time. (Turn one unit on, then wait a moment before turning the other unit on.)
- Do not insert cassettes into both units at a time. (Insert a cassette into one unit, then wait a moment before inserting a cassette into the other unit.)

If you turn on the POWER switches of the recorder and player at a time or insert cassettes to the recorder and player at a time, this unit possibly may not be powered. In this case, turn the POWER switches of both units off, then turn them on again following the above instructions. Should this unit not be powered, turn both POWER switches off and disconnect the AC power cord of the AC-DN2A/DN2B. After about 10 minutes, connect the AC power cord of the AC-DN2A/DN2B again and turn the two units' POWER switches on one by one as mentioned above.

- 1 Remove the cover of the battery connector.

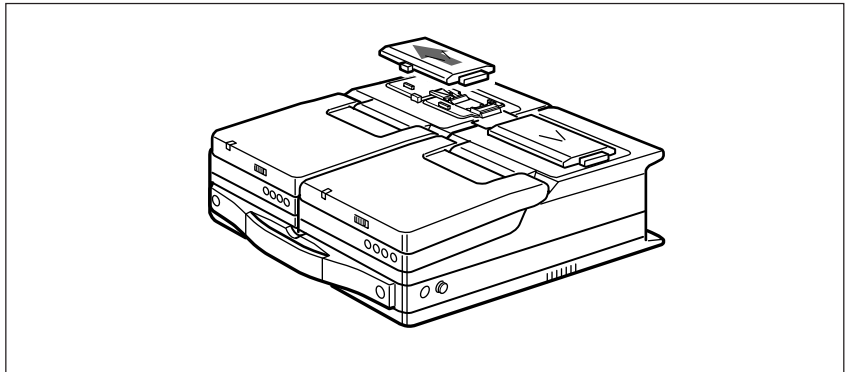

- 2 Insert the V-wedge shoe on the AC-DN2A/DN2B in the V-groove on one unit and slide the AC-DN2A/DN2B until the battery charging connector is connected to the battery connector.

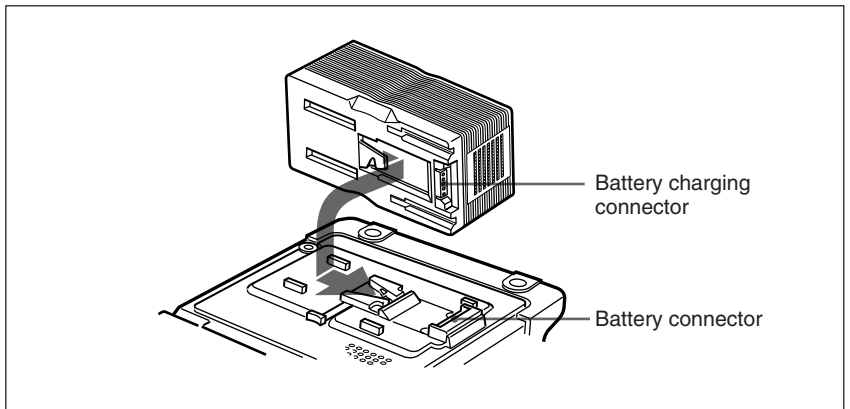

- 3 Use the DC power cord (supplied with the AC-DN2A/DN2B) to connect the DC output connector on the AC-DN2A/DN2B and the DC IN connector on the rear of another unit.

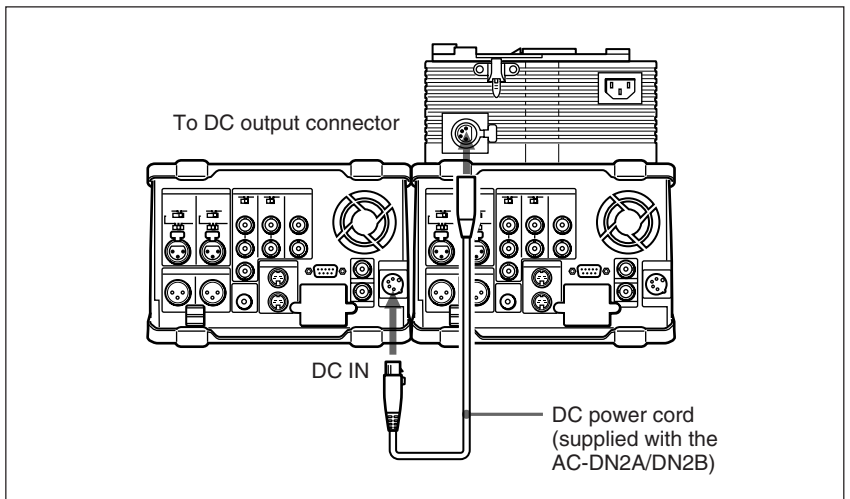

- 4 Supply the AC-DN2A/DN2B with AC power.

For information about how to supply AC power to the AC-DN2A/DN2B, refer to the manual for the AC-DN2A/DN2B.

Recording and Playback

Handling Cassettes

This unit can use standard-size and mini-size DVCAM cassettes listed below.

Model name	Size
PDV-64ME/94ME/124ME/184ME	Standard size
PDVM-12ME/22ME/32ME/40ME	Mini size

The numbers in each model name indicate the maximum recording/playback time (in minutes) for each model. For example, the PDV-184ME has a maximum recording/playback time of 184 minutes.

Cassettes usable for playback only

All consumer DV cassettes and L- and M-size DVCPRO (25M) cassettes are usable for playback only.

Notes

- If you insert an incorrect type of cassette, it will be automatically ejected.
- When operating this unit as a player, you can also use DV cassettes on the unit. However, it is the best choice to always use DVCAM cassettes because they are more reliable than DV cassettes whatever your purpose may be: playback, editing, or long-period storage of recordings.
- Cassettes that have been recorded by a DV-format recorder can be played back on this unit, but you cannot use them to carry out recording by editing. If you insert such a cassette into this unit, the NO EDIT indication lights up in the sub LCD menu home page.

Handling Cassettes

DVCAM cassettes

The following figure illustrates the DVCAM cassette's appearance.

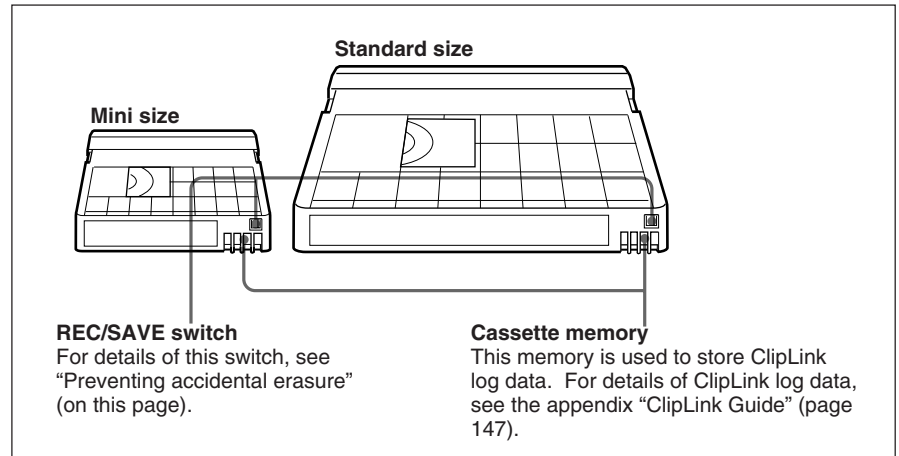

Notes on using cassettes

- Before storing the cassette, rewind the tape to the beginning and be sure to put the cassette in its storage case, preferably on end instead of flat on its side. The storage case of a DVCAM cassette is specially designed to ensure a long-period storage of the tape. Storing a cassette in any other condition (not rewound, out of its case, etc.) may cause the video and audio contents to become damaged over time.
- If the cassette memory connector (contact point) becomes dirty, connection problems may occur and cause a loss of functions. Remove away any dust or dirt from this area before using the cassette.
- If the cassette is dropped on the floor or otherwise receives a hard impact, the tape may become slackened and may not record and/or play back correctly.

For instructions on removing tape slack, see page 39.

Preventing accidental erasure

Set the REC/SAVE switch on the cassette to SAVE to prevent accidental erasure of recorded contents.

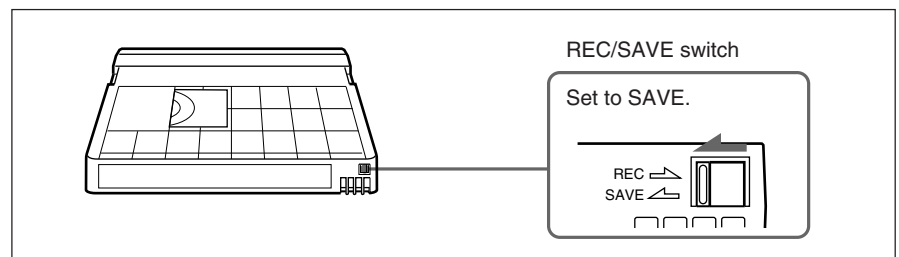

To enable re-recording

Set the cassette's REC/SAVE switch to REC.

If you insert a cassette into the unit when this switch is set to SAVE, the unit will not record when you press the PLAY button while holding down the REC/SEQ button.

Checking the tape for slack

Using a paper clip or a similar object, turn the reel gently in the direction shown by the arrow. If the reel does not move, there is no slack. Insert the cassette into the cassette compartment, and after about 10 seconds take it out.

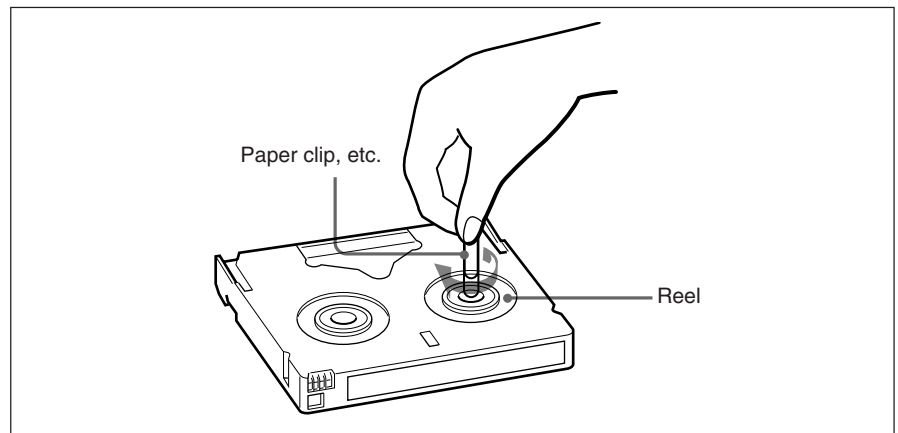

Handling Cassettes

Loading/Ejecting Cassettes

To load a cassette

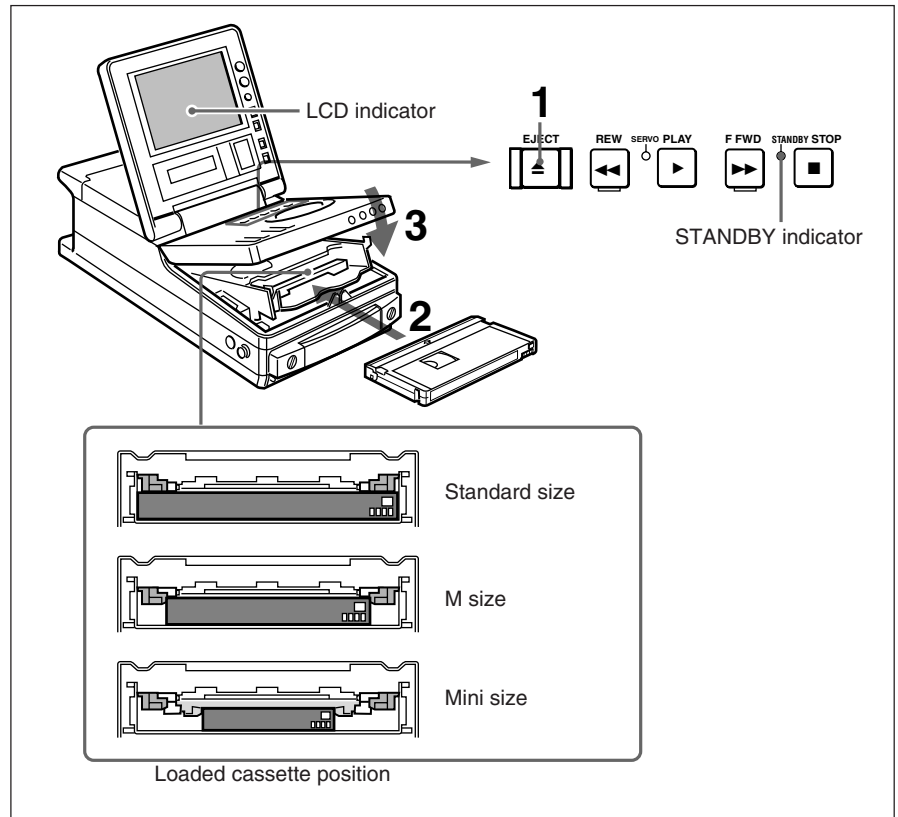

- 1** With the unit powered on, press the EJECT button.

The control panel lifts up and the cassette compartment opens.

- 2** Load a cassette in the direction shown in the figure.

The message “CASSETTE OUT” displayed on the LCD monitor changes to “TAPE UNTHREAD.”

Note

If the message on the LCD monitor does not change to “TAPE UNTHREAD,” redo the cassette insertion procedure.

- 3** Close the control panel. (You should hear a click.)

The STANDBY indicator lights.

To eject the cassette

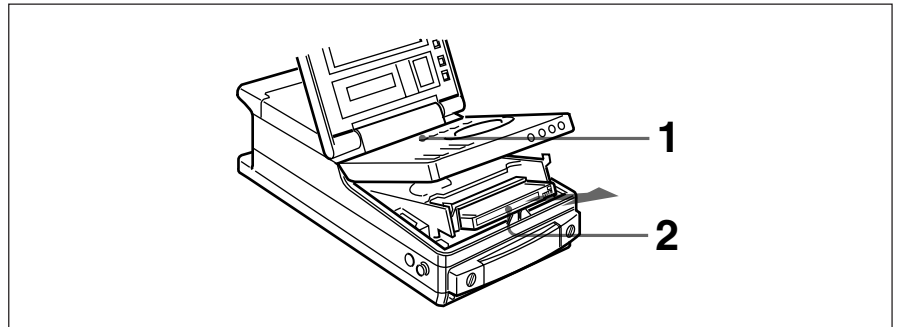

- 1** With the unit powered on, press the EJECT button.

The control panel lifts up and the cassette compartment opens.

- 2** Remove the cassette and close the control panel.

Notes

- Do not shut the display panel while the control panel is still open. Doing so may damage the lock mechanism of the display panel.
- The EJECT button cannot be used to eject a cassette when battery power falls to below about 9 V. Connect an external power supply.

Recording

This section describes recording of external input signals using this unit as a recorder.

Notes

- When two DSR-70A/70AP units are combined, set both REMOTE/LOCAL switches to LOCAL.
- When controlling this unit from the editing control unit connected to the REMOTE connector, set the REMOTE/LOCAL switch to REMOTE.

Preparations for Recording

Perform the following procedure.

- 1** Connect the source signals.
- 2** Select video and audio signals which you want to record (*see step 5 on page 74*).
- 3** Make settings for time data (*see page 59*).

To adjust audio input levels

Set the AUDIO INPUT PRESET/VARIABLE switch on the control panel to VARIABLE. Turn the AUDIO INPUT CH-1 and CH-2 knobs, monitoring the input levels indicated by audio level meter.

Recording Operation

Confirm that the REC INHI indicator on the control panel is not lit. Then, follow the procedure below.

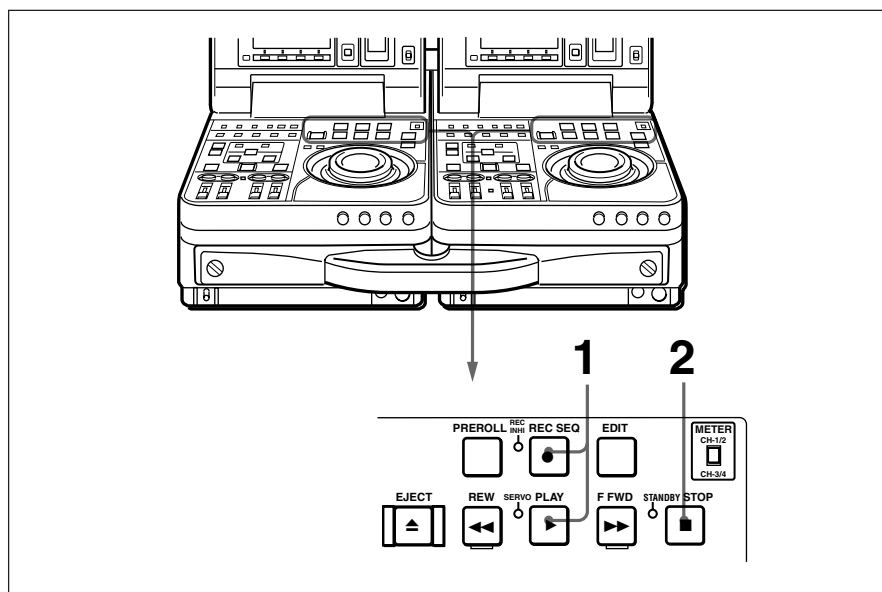

- 1 Press the REC/SEQ and PLAY buttons at the same time.

Recording starts and the POWER indicator turns to red.

- 2 Press the STOP button to stop recording.

If recording continues to the end of the tape, the tape automatically rewinds to the beginning and stops.

Sequential Recording Using Two Units

When you combine two DSR-70A/70AP units, you can perform sequential recording from one unit to another. (In the following explanation of two-unit sequential recording, the controlling unit is referred to as the recorder and the controlled unit as the player.)

For overwriting recording using only two cassettes, the last 6 hours of recording is always available.

By replacing the cassette approximately every 3 hours, indefinite continuous recording is possible.

Sequential recording using two DSR-70A/70AP units can be performed in the following two ways.

- Inputting external video and audio signals to both the player and recorder.
- Inputting external video and audio signals to the player and inputting the video and audio signals output from the player to the recorder.

In either case, you can use the same operating procedure, but there are some differences in equipment/signal connections and basic settings between the two cases.

For more information about equipment/signal connections and basic settings for two-unit sequential recording, see “Connections for Sequential Recording Using Two Units” (page 125).

Use the following procedure. You can do control panel operations on the recorder during sequential recording. Rewind the tape to the beginning beforehand.

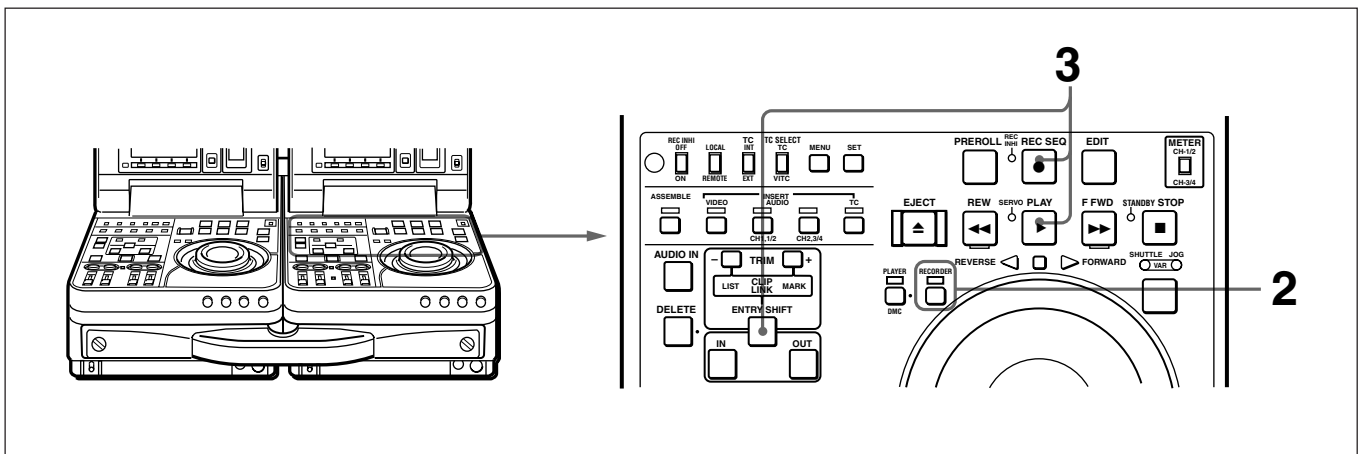

- 1** Insert the cassettes into the recorder and player.
- 2** Press the recorder side RECORDER button to light the RECORDER indicator on the recorder.
- 3** Simultaneously press the recorder side ENTRY/SHIFT button, REC/SEQ button, and PLAY button.

The recorder side begins recording.

The STANDBY indicator of the player goes out. The POWER indicator turns to orange.

The player starts recording automatically when the remaining time of the recorder side tape reaches 2 minutes.

The setting of setup menu item 014 affects what happens when a tape ends.

When AUTOMATIC OVERWRITE is selected

Endless recording on the same cassette continues, overwriting on the previous contents.

When MANUAL CASSETTE REPLACE is selected

When the tape end is reached, the tape is rewound and the EJECT button begins to flash.

To continue recording, insert a new cassette into the recorder. The recorder will start recording automatically when the remaining time of the player side tape reaches 2 minutes.

To stop sequential recording

Sequential recording stops in the following cases.

- When a tape transport button (PLAY, STOP, F FWD, REW) or a search button is pressed during recording.
- If the cassette is not exchanged when the EJECT button flashes though setup menu item 014 is set to MANUAL CASSETTE REPLACE.

Parallel Recording Using Two Units

You can connect two DSR-70A/70AP units and carry out parallel recording between them.

Parallel recording using two DSR-70A/70AP units can be performed in the following two ways.

(In the following explanation of two-unit parallel recording, the controlling unit is referred to as the recorder and the controlled unit as the player.)

- Inputting an external timecode to both the player and recorder.
- Inputting the timecode generated by the recorder to the player.

There are some differences in equipment/signal connections and basic settings between these two cases.

For more information about equipment/signal connections and basic settings for two-unit parallel recording, see “Connections for Parallel Recording Using Two Units” (page 127).

Perform the following procedure.

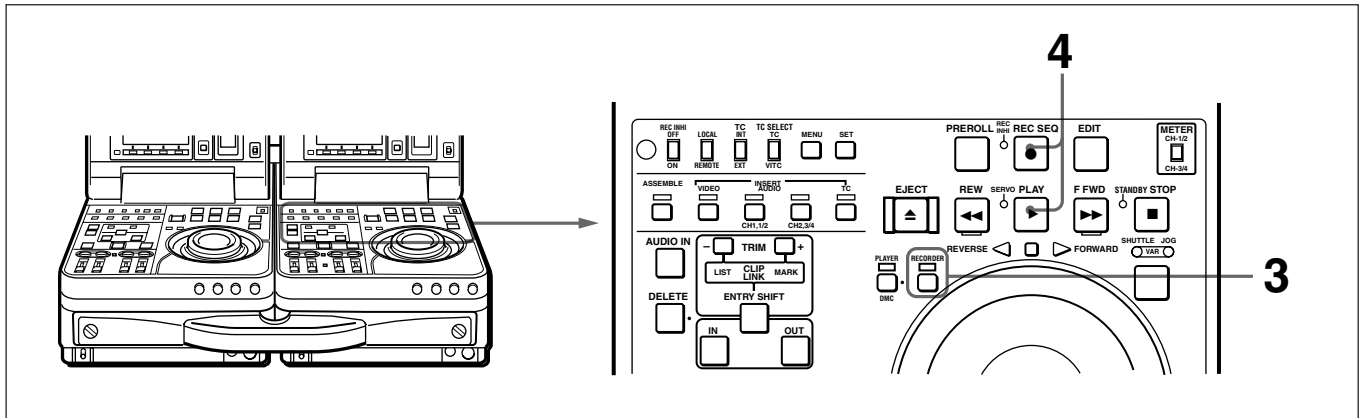

- 1 Insert two recording tapes in the recorder and player.
- 2 When inputting the timecode generated in the recorder to the player, make the required settings for timecode on the recorder.

For more information about timecode settings, see “Setting an Initial Value and Recording Timecode” (page 61).

- 3 Press the RECORDER button or PLAYER/DMC button on the recorder, lighting both the RECORDER and PLAYER/DMC indicators on the recorder.

When both the RECORDER indicator and PLAYER/DMC indicator are lit, the unit is in parallel running mode.

- 4 Holding down the REC/SEQ button, press the PLAY button on the recorder.

The recorder and player start recording at the same time.

To stop parallel recording

Press a tape transport button (PLAY, STOP, F FWD, or REW) or the search button on the recorder.

Two-Input Switched Video Recording (Optional DSBK-180/180P Required)

With the optional DSBK-180/180P Dual Video Input Board installed, you can record, switching between the video signals output by two cameras. (Audio signals are not switched.)

For equipment/signal connections and basic settings, see “Connections for Two-Input Switched Video Recording” (page 130).

To select display mode

In the video settings page (*see page 70*) of the sub LCD menu, select how to display the pictures from the two cameras on the LCD monitor of this unit.

Selections to be made	Corresponding sub LCD menu items (in the video settings page)
Whether to display two input pictures at the same time and, if to display two pictures, how to arrange them.	PP MODE
If picture-in-picture display is selected with the menu item PP MODE, size and position of the smaller picture.	PP SIZE and PP POSI.

For information about sub LCD menu operations, see “Sub LCD Menu Basic Operations” (page 66).

Picture to be recorded

When two-picture display mode is selected, the picture to be recorded is determined as follows.

- When picture-in-picture display is selected:
The larger picture is recorded.
- When two-picture display other than picture-in-picture is selected:
The picture displayed on the left (shown in a red frame) is recorded.

Recording procedure

Perform the following procedure.

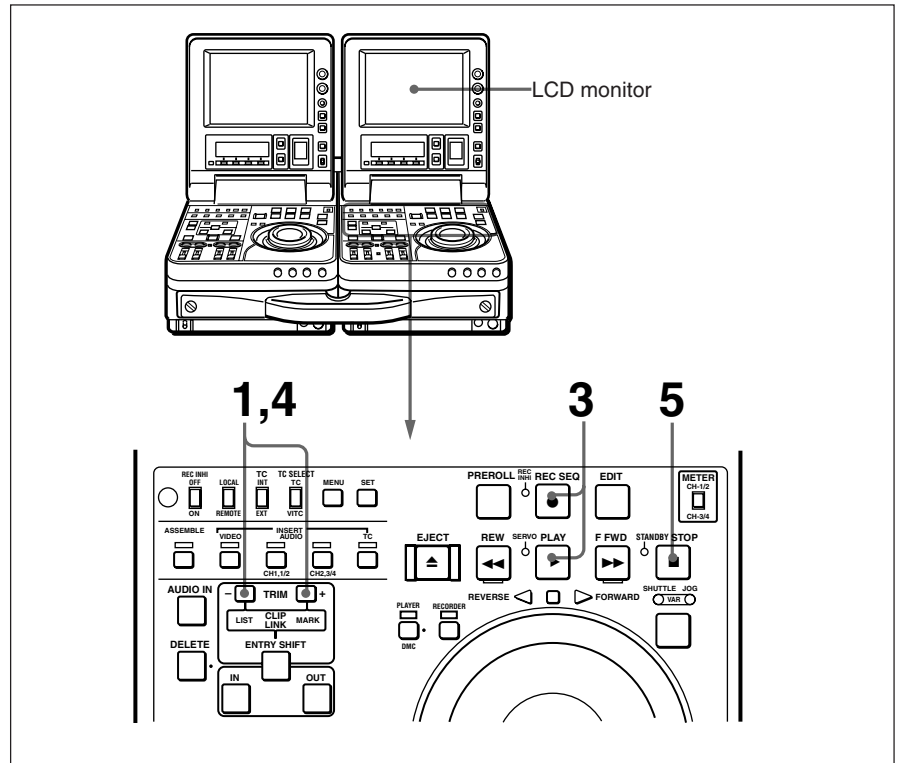

- 1 Holding down the TRIM+/MARK button, press the TRIM-/LIST button.

Each press of the TRIM-/LIST button switches the display on the LCD monitor.

- 2 Make sure that there is no picture discontinuity when the display is switched.

If the picture is deformed at the switching of display

Adjust the output video signal phases between the two cameras.

For the phase adjustment procedure, see the next section.

- 3 When the picture to start recording with is displayed, hold down the REC/SEQ button and press the PLAY button.

Recording starts.

- 4 While watching the LCD monitor display, when you wish to switch the display, hold down the TRIM+/MARK button and press the TRIM-/LIST button.

The display on the LCD monitor as well as the picture being recorded is switched.

(Continued)

- 5 To stop recording, press the STOP button.

Recording stops.

To adjust the output video signal phases

When long cables are used to connect two cameras to this unit, a slight shift in phase between the video signals input from the two cameras may result. When the phase shift is of a significant magnitude, you can detect it as a picture discontinuity on the LCD monitor at the switch between the signals from the two cameras.

To align the phases of the video signals from the two cameras, adjust the phase of the output video signal from one of the two cameras as follows.

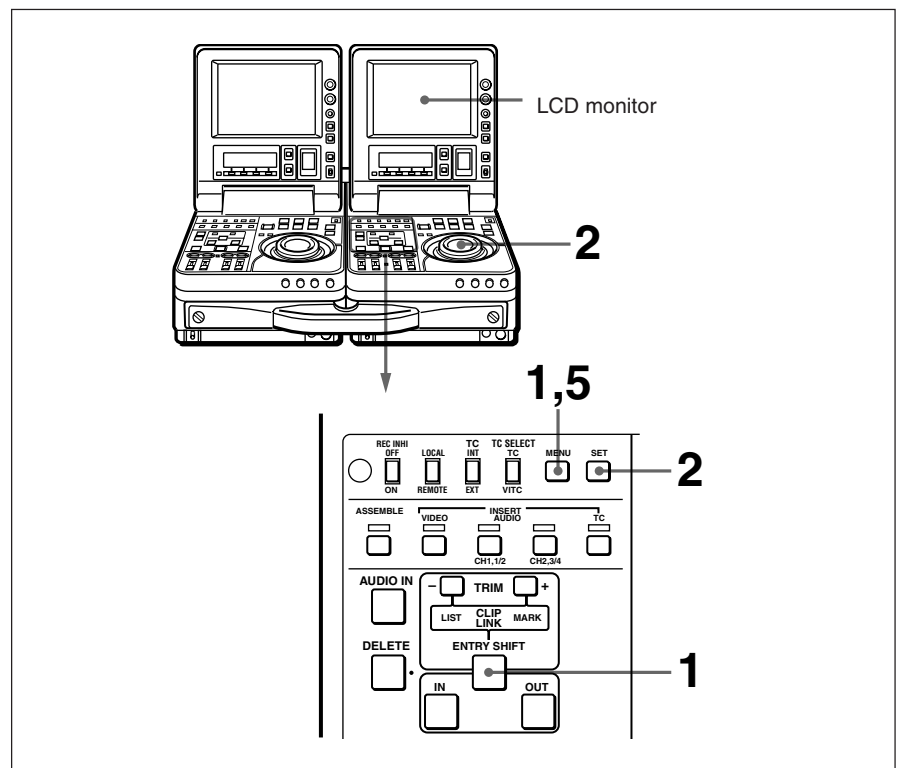

- 1 Holding down the ENTRY/SHIFT button, press the MENU button.

The SYSTEM MENU screen appears on the LCD monitor.



- Using the jog/shuttle dial, select the VIDEO PHASE CHECK item on the SYSTEM MENU screen, then press the SET button.

The pictures from the two cameras are alternately displayed on the LCD monitor (switched 30 times per second (DSR-70A)/24 times per second (DSR-70AP)).

- If the text displayed on the LCD monitor jitters, adjust the H PHASE (horizontal phase) of one of the two cameras until the text stops jittering. (Luminance signal phase adjustment)
- If “NG” is displayed on the LCD monitor, adjust the SC PHASE (subcarrier phase) of the camera to shorten the horizontal bar (representing the magnitude of SC PHASE difference between the two cameras) appearing by the “NG” indication.

When the horizontal bar is appropriately shortened, the “NG” changes to “OK.”

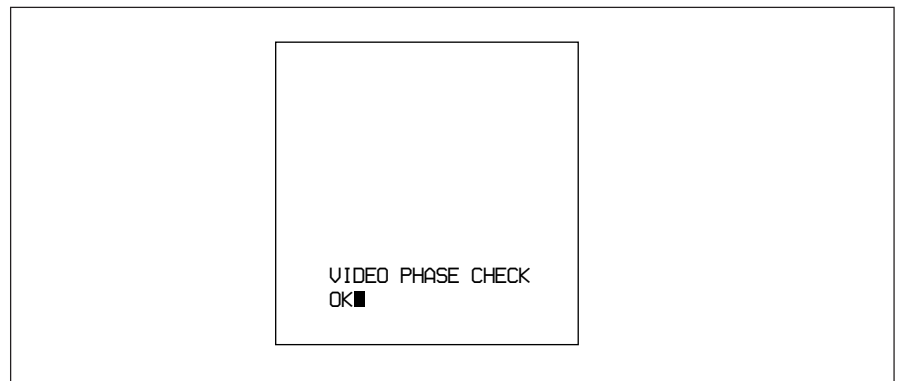

- When the adjustment is completed, press the MENU button to exit from the VIDEO PHASE CHECK menu.

Digitally Dubbing Signals in DVCAM Format (Optional DSBK-140/150/160A Required)

In addition to straightforward tape dubbing, you can also use this unit to digitally dub signals in DVCAM format automatically from the beginning of the tape to the end, through an i.LINK or SDTI(QSDI) interface. When a tape recorded on a DSR-1/1P Digital Videocassette Recorder or DSR-300/300P Digital Camcorder is dubbed, the ClipLink log data held in the cassette memory is also copied.

To use an i.LINK interface requires the optional DSBK-140 or DSBK-160A board, and to use an SDTI(QSDI) interface requires the optional DSBK-150.

For information about connections and basic settings, see “Connections for Digitally Dubbing Signals in DVCAM Format” (page 131).

Notes

- Use a tape which is recorded in the DVCAM format. A tape recorded in DV format cannot be used as a source tape for dubbing through an SDTI(QSDI) or i.LINK interface.
- Regardless of the audio recording mode setting of this unit, dubbing is performed with the original audio recording mode unchanged (two-channel mode (48 kHz) or four-channel mode (32 kHz)).
- Approximately the last 2 minutes of the tape may not be copied because of differences in tape lengths. (If an Index Picture is recorded in this portion, it may also not be copied.)
- A continuous recorded section of approximately 5 seconds is required before the recording start point. It is recommended to record beforehand color bars or a similar signal at the start point of the source tape to be dubbed on this unit.

Perform the following procedure.

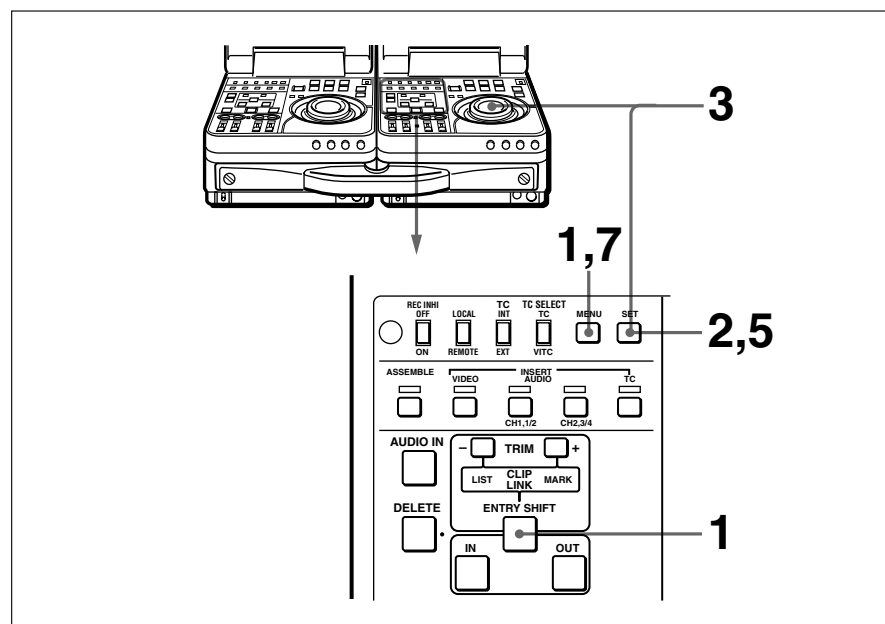

- 1 On the recorder, hold down the ENTRY/SHIFT button and press the MENU button.

The SYSTEM MENU screen appears on the LCD monitor.

- **SYSTEM MENU screen displayed when using the i.LINK interface (DSBK-140/160A)**

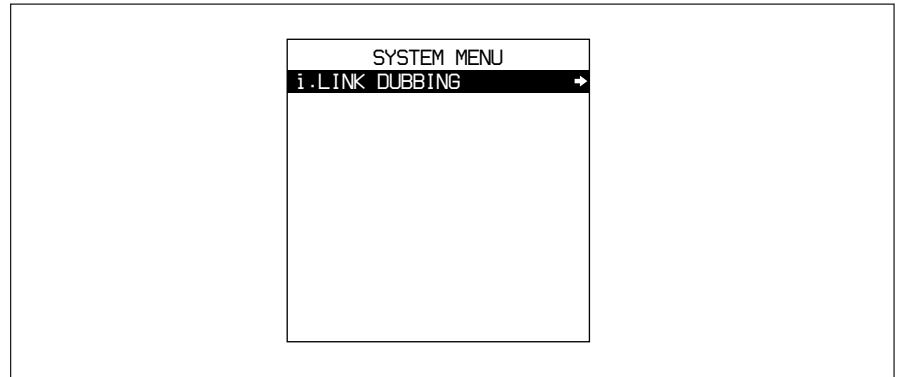

- **SYSTEM MENU screen displayed when using the SDTI(QSDI) interface (DSBK-150)**

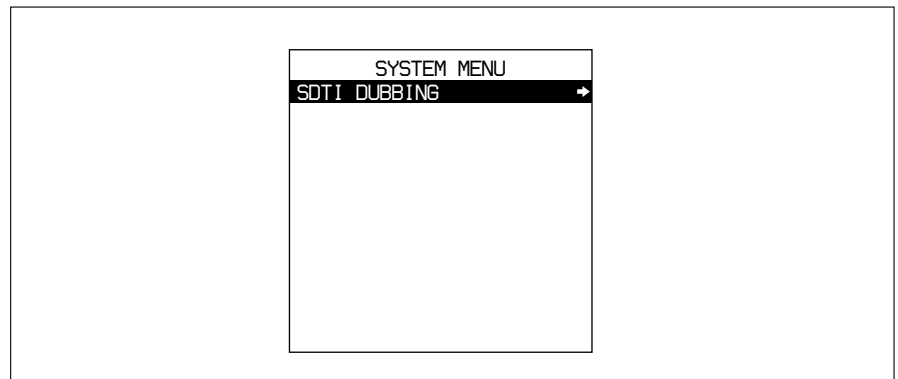

Note

When none of the DSBK-140, DSBK-150 and DSBK-160A is installed in the unit, the setup menu appears instead of the system menu.

In explaining the subsequent steps of this operating procedure, illustrations of screens shown when using the i.LINK interface are used. You can apply the same operating procedure also when using the SDTI(QSDI) interface.

(Continued)

Digitally Dubbing Signals in DVCAM Format (Optional DSBK-140/150/160A Required)

2 Press the SET button.

The screen changes as follows, allowing you to select a desired group of items for dubbing.

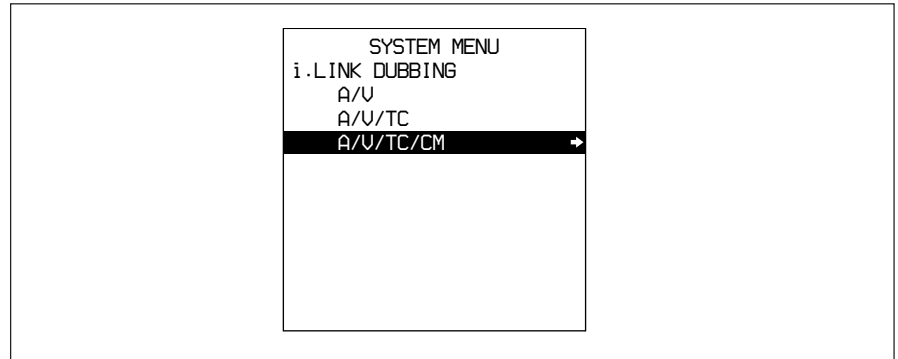

- **A/V:** Audio and video
- **A/V/TC:** Audio, video and timecode
- **A/V/TC/CM:** Audio, video, timecode, and cassette memory (ClipLink log data)

3 Using the jog/shuttle dial, select a desired group of items for dubbing, then press the SET button.

The menu screen changes as follows.
(Example: The screen displayed when A/V/TC/CM is selected.)

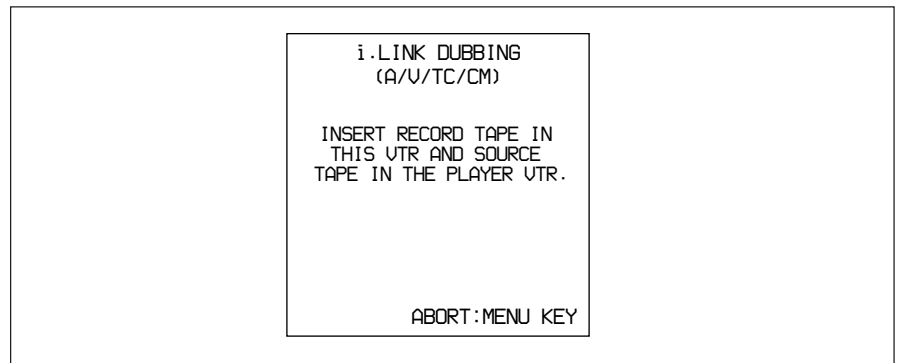

4 Insert the source tape in the player and the recording tape in this unit.

A message to make sure dubbing may be started appears.

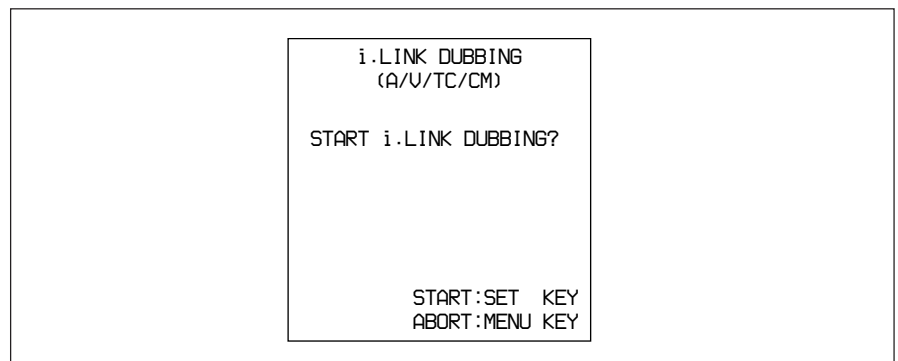

If the cassette memory capacity of the recording tape is not sufficient

A message urging you to replace the recording tape by a tape with a larger cassette memory capacity appears.

For more information about this, see the next section “If the cassette memory of the recording tape is not large enough.”

To cancel the dubbing operation

Press the MENU button.

5 Press the SET button.

The recording tape and source tape are both automatically rewound to the beginning, and dubbing starts. At the same time, the screen changes as follows.

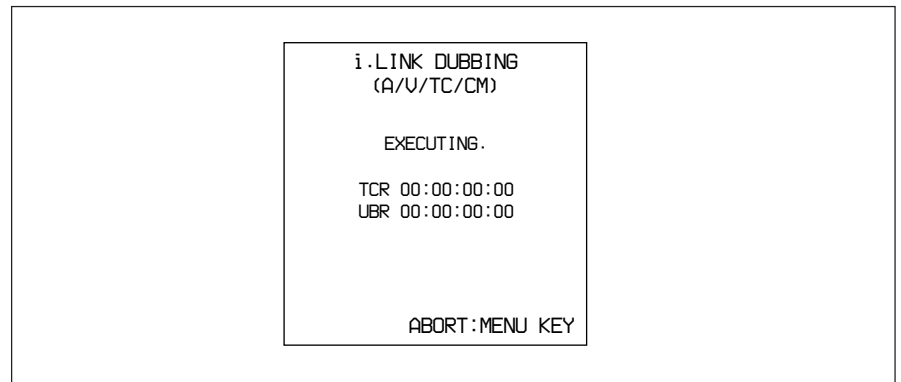

To end the dubbing operation while it is in progress

Press the STOP button.

The dubbing operation stops and a message asking whether to copy the contents of the cassette memory appears.

For more information about this, see “If you end dubbing while it is in progress” (page 54).

When dubbing is completed

- ① A message “COMPLETED” appears on the LCD monitor.
- ② The source tape and recording tape are both automatically rewound to the beginning, and the cassettes ejected.
- ③ The unit returns to the state in step 3.

6 To continue by dubbing another tape, repeat steps 4 and 5.

7 To end the dubbing operation and exit from the menu, press the MENU button.

If the cassette memory of the recording tape is not large enough

When you insert the recording tape and source tape in this unit and the player, respectively, whereas A/V/TC/CM has been selected as the items for dubbing, their cassette memory contents are checked automatically. If, as a result, the cassette memory capacity of the recording tape is found inadequate, the following message appears.

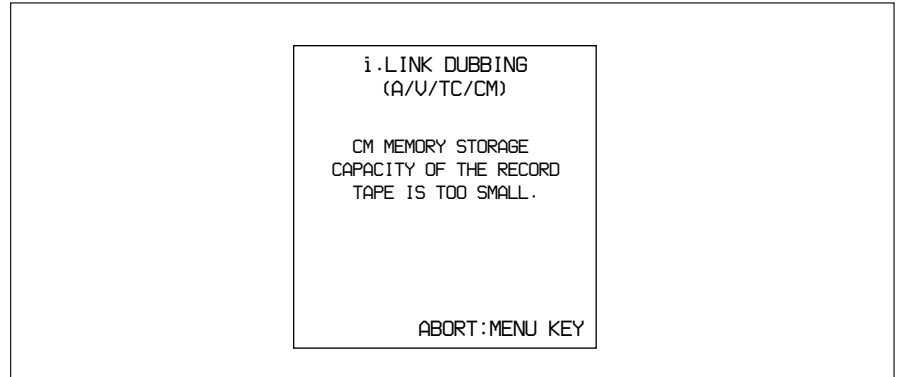

If this message appears, replace the recording tape by a tape with a larger cassette memory capacity.

If you end dubbing while it is in progress

If you end dubbing while it is in progress with A/V/TC/CM selected as the items for dubbing, the following message appears.

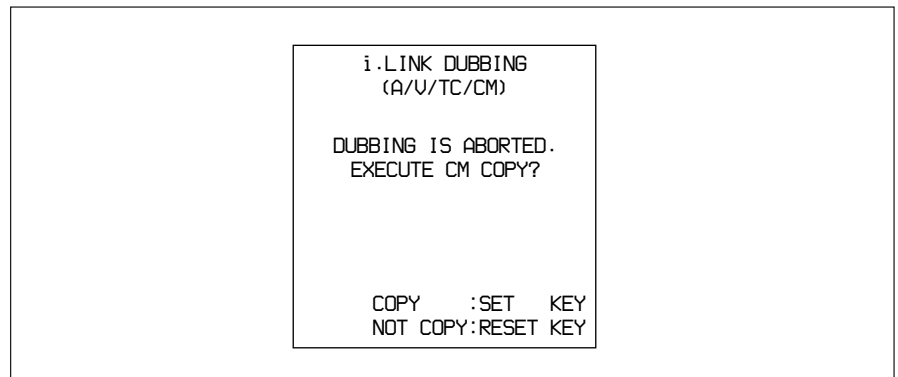

To copy the contents of the cassette memory, press the SET button. If you do not wish to copy the contents of the cassette memory, press the RESET button. If you press the RESET button, however, the contents of the cassette memory may not agree with the material recorded on the tape.

This section describes playback of tapes performed using this unit as a player.

Notes

- When two DSR-70A/70AP units are combined, set both REMOTE/LOCAL switches to LOCAL.
- When controlling this unit from the editing control unit connected to the REMOTE connector, set the REMOTE/LOCAL switch to REMOTE.

For playback using the jog/shuttle dials, see “Finding Edit Points — Search” (page 79).

Preparations for Playback

Perform the following procedure.

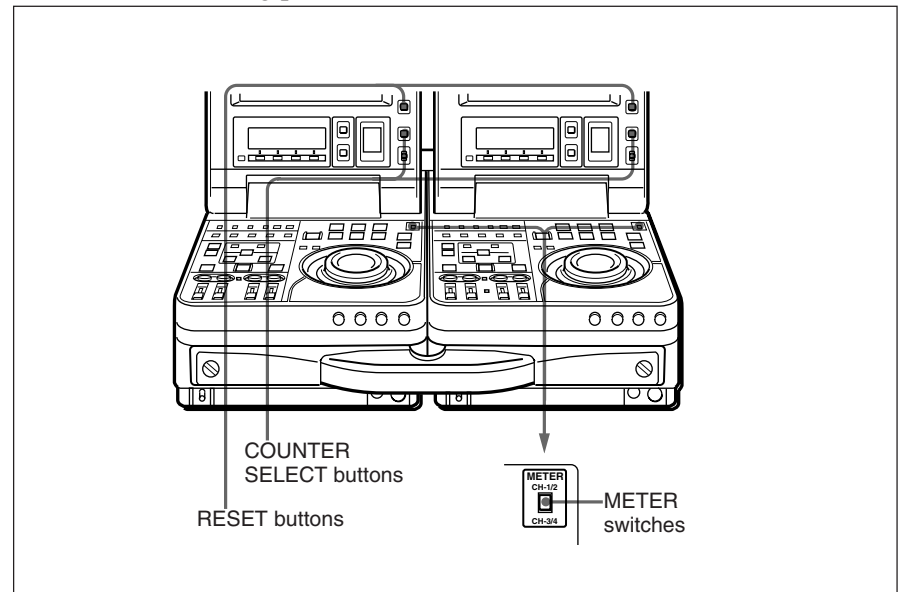

- 1** Connect video/audio signal output connectors to external equipment if necessary.
- 2** Select output audio signals (see “Audio settings page 1-3” (page 69)).
- 3** Press the COUNTER SELECT button to select the time data.

When using COUNTER

Press the RESET button to set the value to “0:00:00:00.”

- 4** Set the METER switch to CH-1/2 or CH-3/4 to select the channels indicated by audio level meter.

Playback Operation

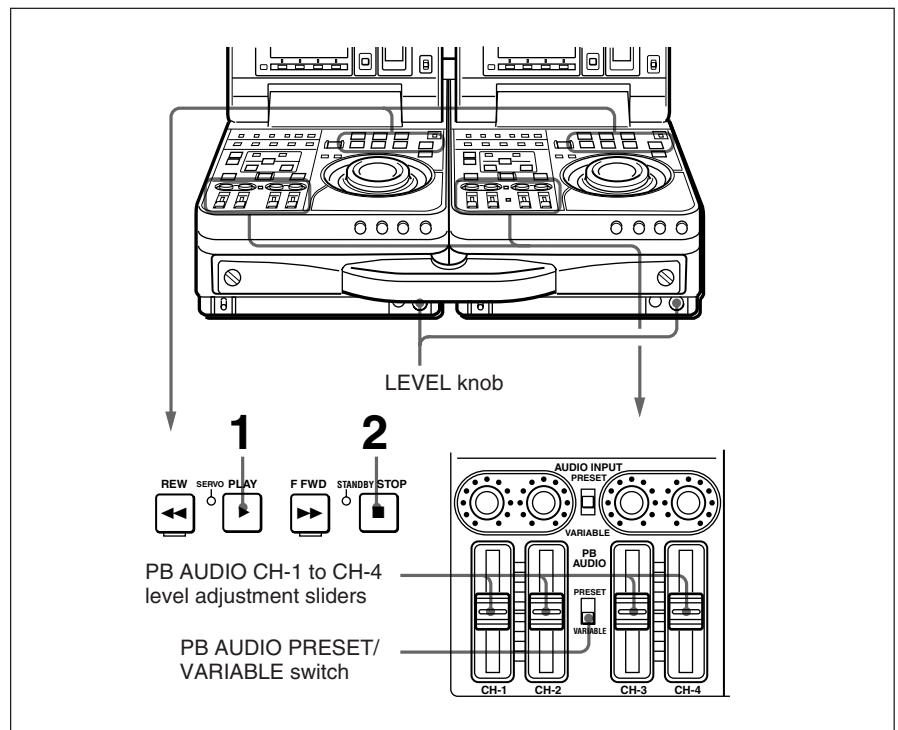

- 1** Press the PLAY button.

Playback starts.

To adjust speaker/headphones audio level

Rotate the LEVEL knob on the front control section.

To adjust audio playback level

Set the PB AUDIO PRESET/VARIABLE switch to VARIABLE, and adjust using the PB AUDIO CH-1 to CH-4 level adjustment sliders.

- 2** Press the STOP button to stop playback.

If playback continues to the end of the tape, the tape automatically rewinds to the beginning and stops.

Two-Unit Synchronous Playback

Connecting two DSR-70A/70AP units and synchronizing their tape transport, you can carry out two-unit synchronous playback with an accuracy of ± 0 frame.

For equipment/signal connections and basic settings, see “Connections for Two-Unit Synchronous Playback” (page 129).

Perform the following procedure.

(In the following, the controlling unit is referred to as the recorder and the controlled unit as the player.)

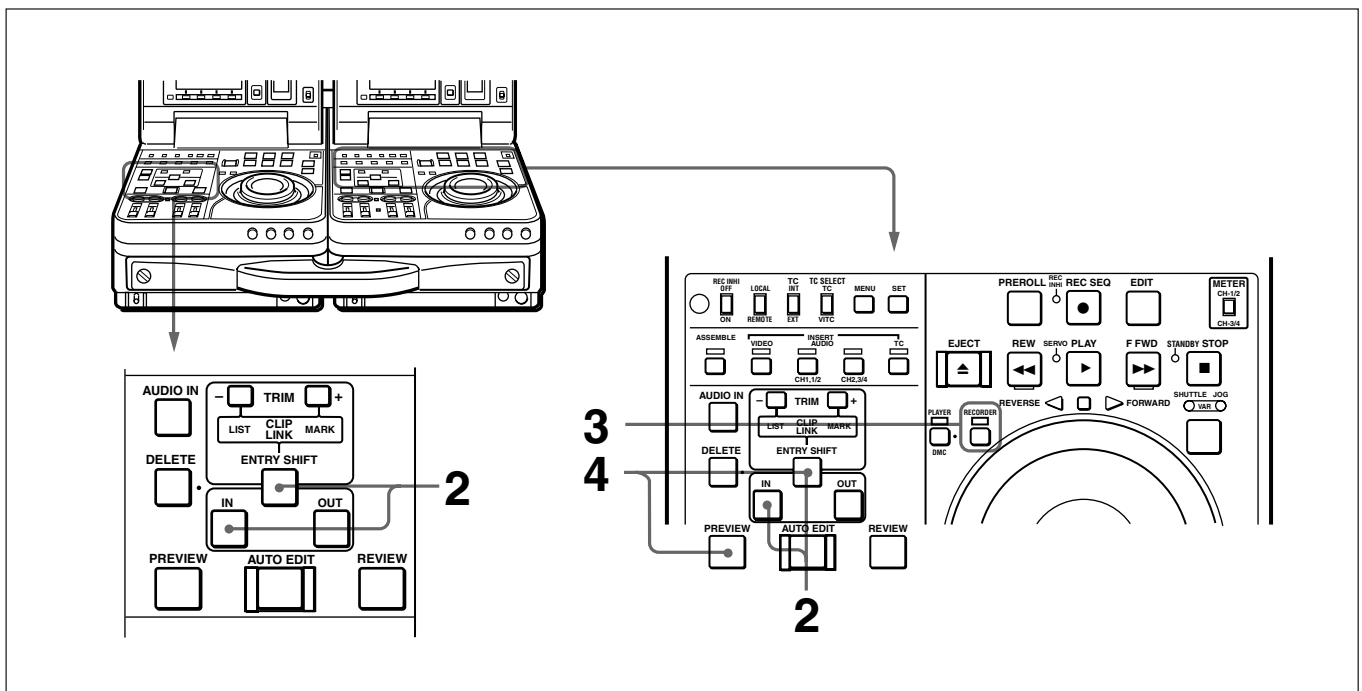

- 1** Insert two source tapes in the recorder and player.
- 2** Cue up to the tape position where to start playback on each of the recorder and the player, then, holding down the ENTRY/SHIFT button, press the IN button.

On each unit, the cued-up tape position is set as the IN point and the IN button lights.

- 3** Press the RECORDER button, lighting the RECORDER indicator.

(Continued)

- 4** On the recorder, holding down the ENTRY/SHIFT button, press the PREVIEW button.

Both the recorder and the player start preroll followed by playback by the two units.

When the setup menu item 004 is set to ON and 305 set to ACCUR on the recorder side, the recorder and player tape transports are synchronized during the preroll allowing two-unit synchronous playback with ± 0 frame accuracy to start at the player and recorder IN points.

To end synchronous playback while it is in progress

Press the STOP button on the recorder.

Time Data and Sub LCD Menu

Setting Time Data

This unit provides the following timecode functions:

- Setting, displaying, recording, and playing back timecode and user bit values
- Outputting the timecode read from the tape as an analog timecode (LTC) signal during playback
- Inputting an external analog timecode (LTC) signal

Information Displayed on the LCD Monitor

The LCD monitor displays setup menus, error messages, alarm messages, time data, and information about the unit's operating status.

For more information about the setup menus, see Chapter 7 "Setup Menu" (page 103).

To adjust the screen

Use the BRIGHT and CONTRAST knobs to adjust the brightness and contrast of the LCD monitor screen. To make the backlight brighter, set the sub LCD menu item BACKLGT to HIGH (*see page 72*).

To display superimposed text information

To display superimposed time data and text information about the operating status of the unit in the LCD monitor, set the sub LCD menu item CHARACTER to ON (*see page 71*). The setup menu and error messages are displayed regardless of the setting of CHARACTER.

When CHARACTER is set to ON, the text information is also superimposed on the output of the VIDEO OUTPUT 2 (SUPER) connector .

To adjust the displayed text

You can adjust the position, size, and type of superimposed information using setup menu items 002, 003, 009, and 011.

For details, see pages 104 and 105.

Setting Time Data

Information displayed

The figure below shows the time data and operation status that can be superimposed.

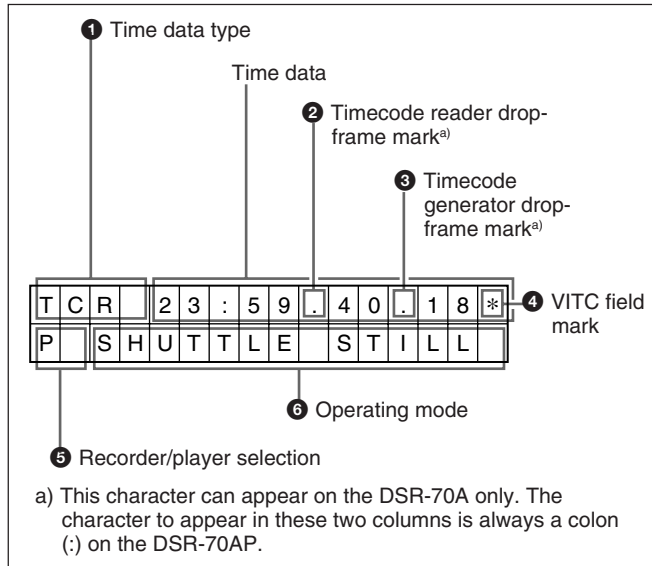

Note

The example above shows the factory default configuration.

You can use setup menu item 005 to display a different type of time data in the second line as well.

For details, see page 104.

1 Time data type

Display	Meaning
CNT	Count value of the time counter (COUNTER)
TCR	Timecode reader timecode data
UBR	Timecode reader user bits data
TCR.	VITC reader timecode data
UBR.	VITC reader user bits data
TCG	Timecode generator timecode data
UBG	Timecode generator user bits data
IN	IN point time data
OUT	OUT point time data
AI	Audio IN point time data
DUR	The duration between any two of the four edit points (IN, OUT, AUDIO IN, AUDIO OUT)
T*R ^{a)}	Time code data from time code reader. The asterisk indicates an interpolation by the time code reader to make up for the time code data not correctly read from the tape.
U*R ^{a)}	User bit data from the time code reader. The asterisk indicates that last data is retained by the time code reader, as the new data has not been read correctly from the tape.

a) “*” appears when data has not been correctly read from tape.

2 Timecode reader drop-frame mark (for DSR-70A only)

.	Drop frame mode (factory default setting)
:	Non-drop frame mode

3 Timecode generator drop-frame mark (for DSR-70A only)

.	Drop frame mode (factory default setting)
:	Non-drop frame mode

4 VITC field mark

“ ” (blank): Fields 1 and 3

“*”: Fields 2 and 4

5 Recorder/player selection

The indication changes depending on the status of the PLAYER/DMC and RECORDER indicators.

No display: When the PLAYER/DMC and RECORDER indicators are both not lit.

P: The PLAYER/DMC indicator is lit.

R: The RECORDER indicator is lit.

6 Operating mode

The field is divided into three blocks, A, B and C.

- Block A displays the operating mode.
- Block B displays the servo lock status or tape speed.
- Block C displays a ■ mark to indicate an edit section during automatic editing.

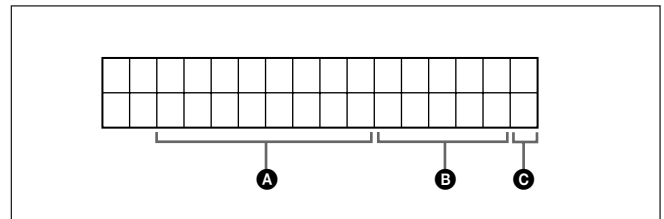

Display		Operating mode
Block A	Block B	
CASSETTE OUT		Cassette is not loaded
TAPE UNTHREAD		Tape has not been threaded
STANDBY OFF		Standby off mode
T.RELEASE		Tape tension released
STOP		Stop mode
F.FWD		Fast forward mode
REW		Rewind mode
PREROLL		Preroll mode
PLAY		Playback mode (servo unlocked)
PLAY	LOCK	Playback mode (servo locked)
REC		Record mode (servo unlocked)
REC	LOCK	Record mode (servo locked)
SEQ-REC		Sequential recording mode (servo unlocked)
SEQ-REC	LOCK	Sequential recording mode (servo locked)
EDIT		Edit mode (servo unlocked)
EDIT	LOCK	Edit mode (servo locked)
JOG	STILL	A still picture in jog mode
JOG	FWD	Jog mode in forward direction
JOG	REV	Jog mode in reverse direction
SHUTTLE	(Speed)	Shuttle mode
VAR	(Speed)	Variable speed mode
AUTO EDIT		Automatic editing mode
PREVIEW		Preview mode
REVIEW		Review mode
D-PREV	(Speed) ^{a)}	DMC editing preview mode
D-EDIT	(Speed) ^{a)}	DMC editing mode
DMC-SPD	(Speed)	DMC initial speed setting

a) Initial speed settings or stored speed settings

Setting an Initial Value and Recording Timecode

Set the switches and sub LCD menu items as shown below.

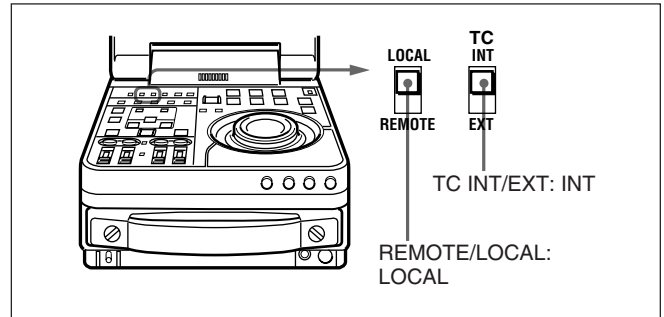

Sub LCD menu settings

Item	Setting
F-RUN/R-RUN	Desired setting
DF/NDF (general settings page)	Desired setting (for DSR-70A)

To set an initial timecode value

Perform the following procedure.

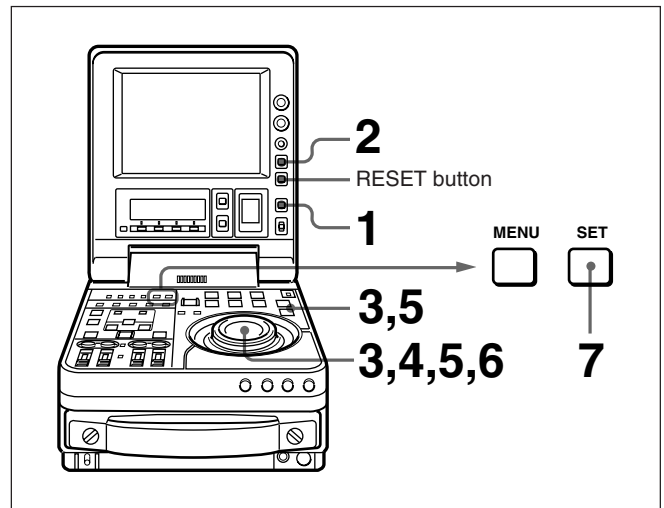

- 1 Press the COUNTER SELECT button and select TC.

(Continued)

Setting Time Data

2 Press the HOLD button.

The first digit of the time data (hours:minutes:seconds:frames) in the sub LCD begins to flash.

To set all digits to 0

Press the RESET button.

3 Confirm the JOG indicator lights, and select jog mode if not. (Shuttle mode is not recommendable.)

4 Select the digit to set by rotating the jog dial.

The flashing digit changes to the digit on the right when you rotate the jog dial clockwise, and to the digit on the left when you rotate it counterclockwise.

5 Set the value for the flashing digit by rotating the jog dial while pressing the search button.

6 Repeat steps 4 and 5 until you finish setting all digits.

7 Press the SET button.

If the sub LCD menu item F-RUN/R-RUN is set to F-RUN, the timecode starts to advance immediately.

To set timecode to the current time

1 Set the sub LCD menu item F-RUN/R-RUN to F-RUN and DF/NDF to DF (for DSR-70A) (see page 71).

2 Carry out steps 1 to 6 of “To set an initial timecode value” (page 61) to set the timecode to a time slightly ahead of the current time.

3 Press the SET button at the instant when the current time matches the displayed timecode.

To set user bits

You can record up to 8 hexadecimal digits of information (date, time, event number, etc.) in the timecode track.

Proceed as follows.

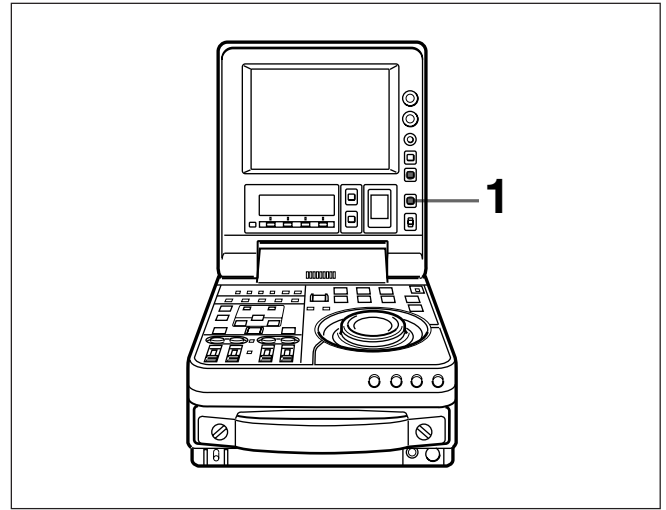

1 Press the COUNTER SELECT button and select UB.

2 Carry out steps 2 to 7 of “To set an initial timecode value.”

Settings are made in hexadecimal (0, 1, 2,... 8, 9, A, B,... E, F).

Synchronizing the Internal Timecode Generator With an External Signal — External Lock

You can synchronize the internal time code generator to an external time code signal (TC) input to this unit. Use this method to synchronize the time code generators of a number of VCRs, or to carry out recording maintaining the synchronization between the source video and time code.

In this case, the settings of the sub LCD menu items F-RUN/R-RUN and DF/NDF are ignored.

You can synchronize the internal time code generator to one of the following external time codes.

- The time code (TC) output of an external time code generator or external VCR connected to the TC IN connector
- The time code (VITC) present in a video signal input to the unit
- The time code (TC/VITC) input to the SDTI(QSDI) INPUT connector (when fitted with the optional DSBK-150) or i.LINK connector (when fitted with the optional DSBK-140/160A) of the unit

To synchronize to an external time code signal

Proceed as follows.

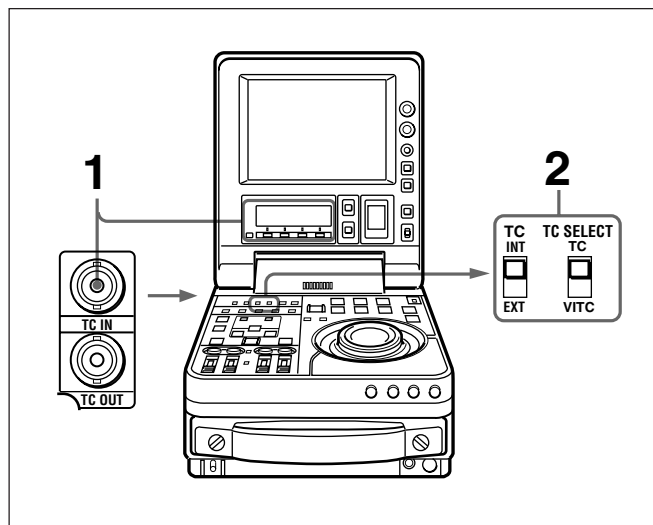

- 1 • When synchronizing to an external time code Connect the time code output of the external time code generator or external VCR to the TC IN connector.

- When synchronizing to the time code (VITC) in an input video signal
In the input selection section, select an input video signal containing VITC, then select TC or VITC with extended menu item 613.

- 2 Set switches on the control panel and the sub LCD menu as follows.

TC SELECT switch: TC or VITC according as you are synchronizing to TC or VITC

TC INT/EXT switch: EXT

Sub LCD menu item VITC:

- To record the time code (VITC) in the input video signal as VITC, set to OFF.
- To record the time code generated by the internal time code generator as VITC, set to ON.

This starts the internal time code generator running in synchronization with the external time code generator. Once the internal time code generator is synchronized with the external time code generator, even if the external time code generator connection is removed, the internal time code generator continues to run.

Note

When the input mode is SDTI or i.LINK (the SDTI or i.LINK indicator is present in the subsidiary LCD), then setting the TC INT/EXT switch to the EXT position automatically synchronizes the internal timecode generator to the timecode transferred through the SDTI (DSBK-150) or i.LINK (DSBK-140/160A) interface.

Note that when the TC INT/EXT switch is set to EXT, the advance mode and frame count mode (DSR-70A only) are automatically set as follows.

Advance mode: free running

Frame count mode (DSR-70A only): the same as the external timecode signal (drop frame or non-drop frame)

Checking the synchronization to the external signal

Press the STOP button to stop this unit, then press the REC/SEQ button.

Watch the time data display, and check that the values displayed coincide with the external timecode values.

Sub LCD Menu Display and Settings — Making Operating Mode and Video/Audio Signal Settings

The sub LCD menu displayed in the sub LCD allows you to make operating mode and video/audio signal settings for the unit.

Sub LCD Menu Home Page and Sub LCD Operation Buttons

The home page of the sub LCD menu is displayed when you power the unit on.

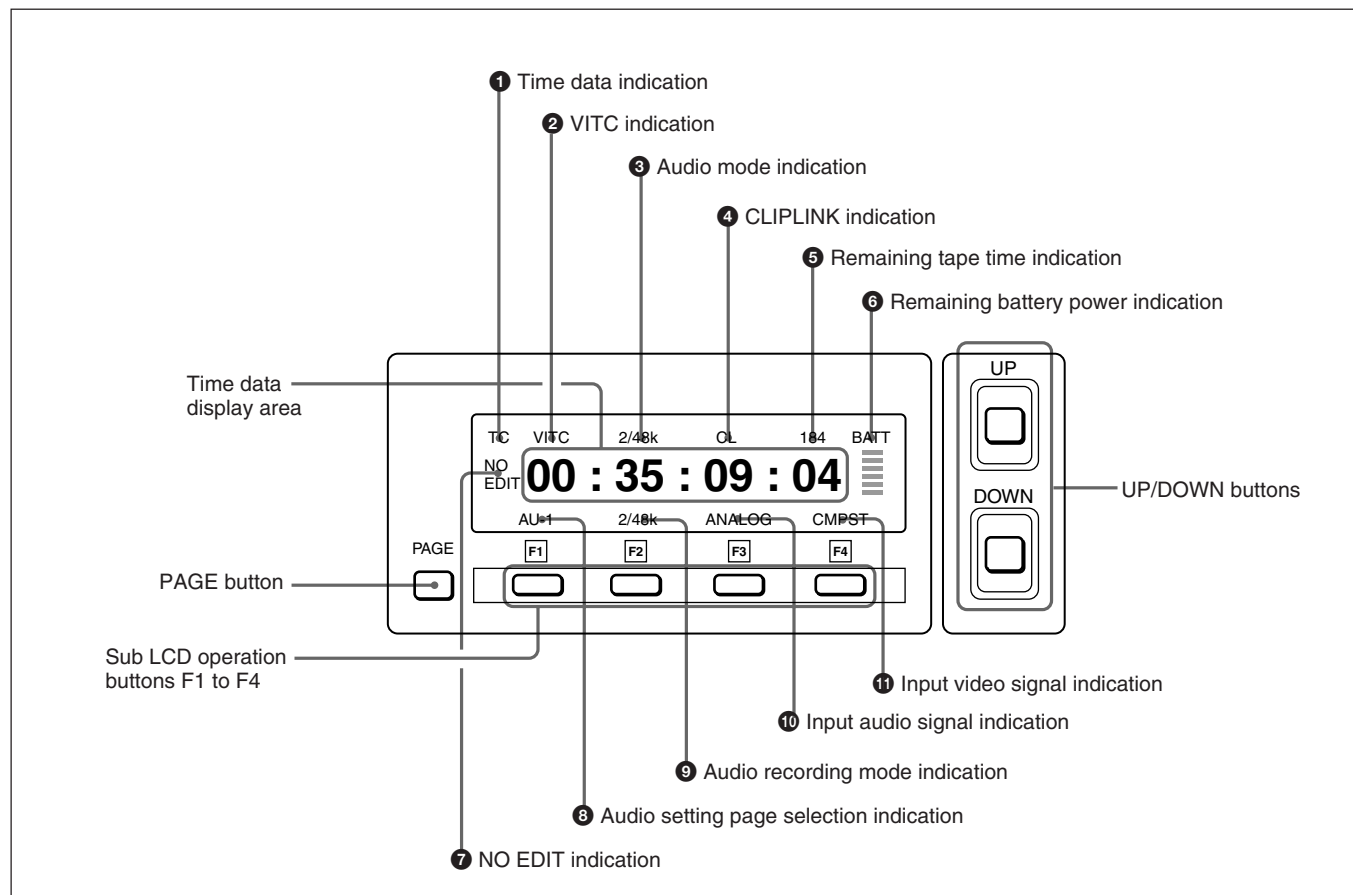

1 Time data indication

Shows the type of time data being displayed.

- TC:** Timecode
- UB:** User bits
- CNT:** Counter count

2 VITC indication

Lights when VITC timecode is being read or recorded, regardless of the time data indication.

3 Audio mode indication

This shows the mode in which audio is recorded.

- 2/48k:** two-channel, 48 kHz mode
- 4/32k:** four-channel, 32 kHz mode
- :** recording mode cannot be determined

4 CLIPLINK indication

These show whether or not cassette memory is present and whether there is CLIPLINK log data.

- CM:** appears when there is cassette memory
- CL:** appears when the cassette memory includes CLIPLINK log data.
- No indication:** when there is no cassette memory

5 Remaining tape time indication

Displays the remaining tape time (in 2-minute increments).

–: No cassette is loaded.

When the remaining time falls to 2 minutes or less, the indication becomes 0 and flashes.

When a tape recorded in DV format (SP mode) is played back, indication “SP” appears. When a tape recorded in DVCPRO (25M) format is played back, indication “MP” appears.

6 Remaining battery power indication

Displays the remaining battery power on a scale of seven levels. When the power is nearly exhausted, the BATT display flashes. When the power is completely exhausted, a flashing E (End) appears.

Regarding the remaining battery power indication, also see “**3** BAT-END (battery end) setting” and “**4** BAT-NE (battery near end) setting” (page 72).

7 NO EDIT indication

Appears when a tape recorded in DV or DVCPRO (25M) format is played back.

You may play back a tape recorded in DV or DVCPRO (25M) format, but you cannot record the results of editing on the tape.

This indication appears also when the audio recording mode set on the unit is different from the audio recording mode used on the tape.

8 Audio settings page selection indication

To select one of the groups of the audio settings pages (AU-1 to AU-4) or MIX/SWP, press F1 to highlight this display, then press the UP or DOWN button. The selected page in the group or the audio settings sub page appears when you press the PAGE button.

For details, see “To switch between menu pages” (page 66).

9 Audio recording mode indication

When changing the audio recording mode selection, use F2 to highlight this indication, then press the UP button or the DOWN button so that the indication for the desired mode appears in the sub LCD.

2/48k: Two-channel, 48-kHz mode

4/32k: Four-channel, 32-kHz mode

Pressing first F2 to highlight this indication, then the PAGE button displays the general settings page (1) (see page 71).

10 Input audio signal indication

When changing the input audio signal selection, use F3 to highlight this indication, then press the UP button or the DOWN button repeatedly so that the indication for the desired signal appears in the sub LCD.

ANALOG: Analog signals

SG: Test audio signal

i.LINK: i.LINK(DV) signals (DSBK-140/160A)

SDTI: SDTI(QSDI) signals (DSBK-150)

SDI: SDI signals (DSBK-160A)

Pressing F3 to highlight this indication, then pressing the PAGE button displays the general settings page (1) (see page 71).

11 Input video signal indication

You can select CMPST (composite) or SDI as the input video signal by pressing F4 to highlight this display and then pressing the UP or DOWN button.

CMPST: Composite signal

SDI: SDI signal (DSBK-160A)

S VIDEO: S-video signal

SG: Test video signal

i.LINK: i.LINK (DV) signal (DSBK-140/160A)

CMPNT: Component signal (DSBK-170)

SDTI: SDTI (QSDI) signal (DSBK-150)

If you press the PAGE button after highlighting this display, the video settings page appears, allowing you to make advanced video settings.

For details, see “To switch between menu pages” (page 66).

Note

Selecting the i.LINK or SDTI (QSDI) signals for input audio causes the same to be automatically selected also for input video.

Selecting the i.LINK or SDTI (QSDI) signals for input video causes the same to be automatically selected also for input audio.

Sub LCD Menu Basic Operations

To switch between menu pages

In addition to the home page, the sub LCD menu has pages that allow you to make settings for input and output of video and audio signals, and other general settings.

You can switch between pages by pressing the buttons shown in the figure below.

For more information about the video and audio settings pages, see “Input and Output Settings for Video and Audio Signals” (page 68).

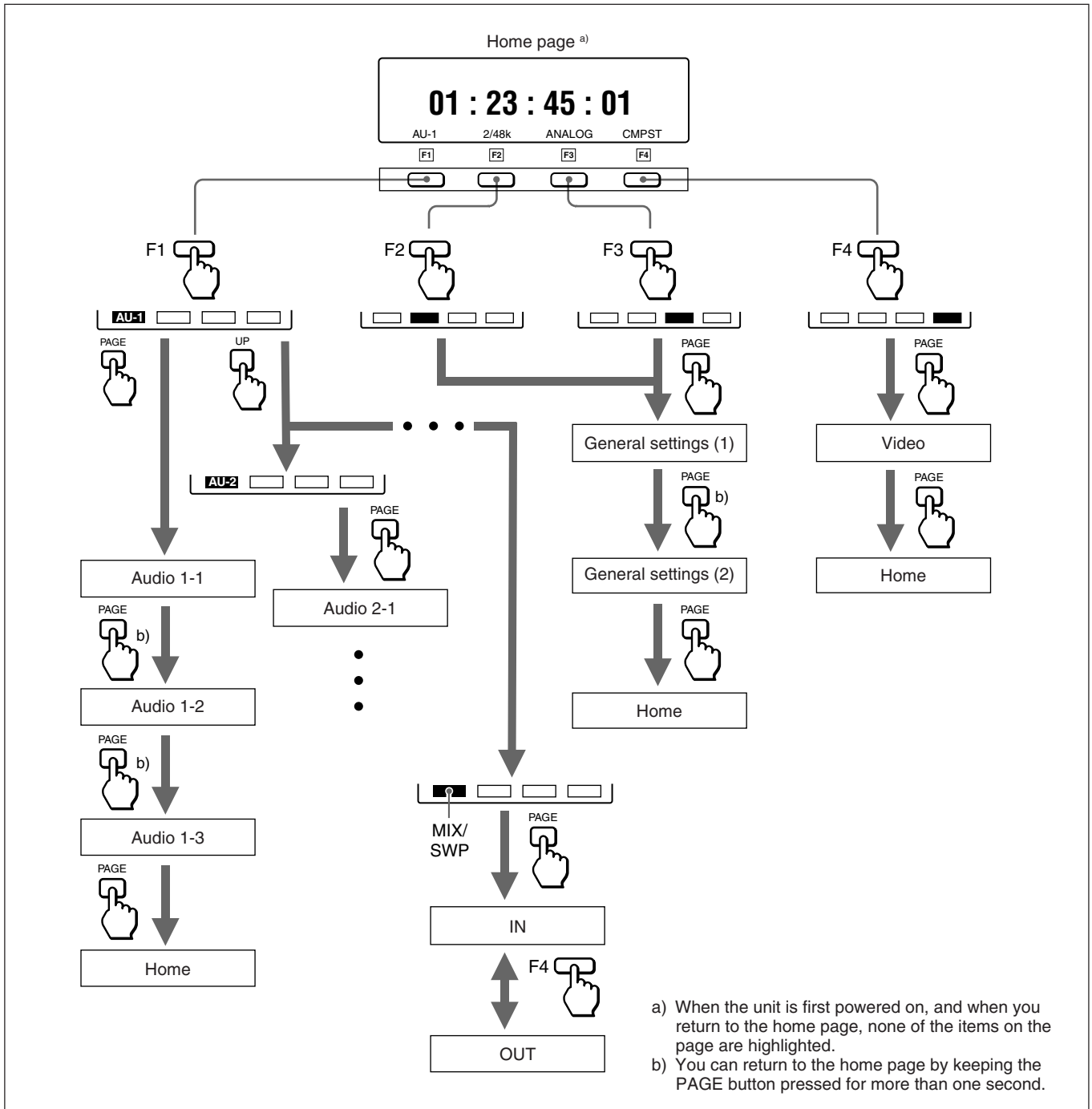

To select an item

Display the page that contains the item you want to select, then press F1 to F4, that is located in the same column as the item.

The selected item is highlighted.

Press the button repeatedly until the item that you want to select is highlighted.

To change a setting

With the item that you want to change highlighted, press the UP or DOWN button repeatedly until the item is set to the value that you want.



Input and Output Settings for Video and Audio Signals — Sub LCD Menu

Using the sub LCD menu, you can make settings related to the input and output of video and audio signals.

For more information about basic sub LCD menu operations, see “Sub LCD Menu Basic Operations (page 66).”

Making Settings in the Audio Settings Pages

For audio settings, use the audio settings pages of the sub LCD menu.

The audio settings pages are divided into four groups, AU-1 to AU-4. Using these four groups of audio settings pages, you can make four different sets of audio settings. To call up one of the settings pages in a group, select the group from the home page.

Each settings page has a number that indicates its group and its position within the group. For example, audio settings page 1-1 is the first page in group AU-1.

Audio settings page 1-1

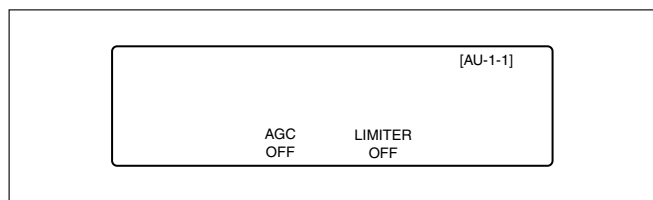

Item	Setting
AGC	Turn the audio input AGC circuits ON and OFF (enabled when the AUDIO INPUT PRESET/VARIABLE switch of the control panel is set to PRESET).
LIMITER	Turn the audio input limiter circuits ON and OFF (enabled when the AUDIO INPUT PRESET/VARIABLE switch of the control panel is set to VARIABLE).

To switch to audio settings page 1-2

Press the PAGE button.

Audio settings page 1-2

Audio settings page 1-2 displayed differs between when the optional DSBK-140/150/160A board is installed and when it is not installed.

Display when the optional DSBK-140/150/160A board is installed

CH	MIX/SWAP		[AU-1-2]
1*IN-1	2 IN-1	3 IN-1	4 IN-1
IN-2	*IN-2	IN-2	IN-2
IN-3	IN-3	*IN-3	IN-3
IN-4	IN-4	IN-4	*IN-4

Display when the optional DSBK-140/150/160A board is not installed

CH	MIX/SWAP		[AU-1-2]
1*IN-1	2 IN-1	3*IN-1	4 IN-1
IN-2	*IN-2	IN-2	*IN-2

Item	Setting
MIX/SWAP CH 1 to 4	<p>Select up to two audio input signals (IN-1 to IN-4) to be assigned to channels 1 to 4. When two signals are selected, they are mixed.</p> <p>To select</p> <ol style="list-style-type: none"> 1 Select the desired channel using operation buttons F1 to F4. 2 Press the same operation button as used in 1 repeatedly until the input signal indication (IN-1/IN-2/IN-3/IN-4) corresponding to the desired signal is highlighted. 3 With the input signal indication for the selected signal highlighted, press either the UP button or the DOWN button so that an asterisk (*) is added to the highlighted input signal indication. 4 To select the second input signal for the same channel, repeat steps 2 and 3. <p>To cancel the selection</p> <p>Proceed as above to highlight the desired input signal indication, then press either the UP button or the DOWN button so that the asterisk preceding the highlighted input signal indication disappears.</p> <p>Note</p> <p>When analog audio (ANALOG) has been selected for input, selecting IN-3 or IN-4 as the audio input signal results in mute audio.</p>

To switch to audio settings page 1-3

Press the PAGE button.

Audio settings page 1-3

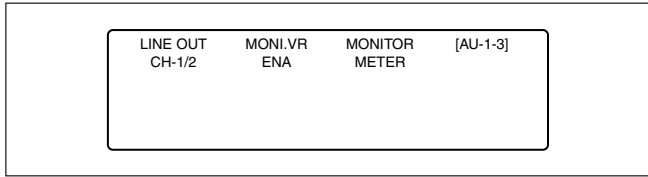

Item	Setting
LINE OUT	Select channels 1/2 or 3/4 as the line out channels.
MONI.VR	Select ENA for an output level determined according to the setting of the PB AUDIO PRESET/VARIABLE switch of the control panel, or DIS for a fixed output level.
MONITOR	Select the monitor audio output signal. <ul style="list-style-type: none"> • Select METER to linking the monitor audio output selection to the setting of the METER switch for the display panel. Either channels 1 and 2 mixed or channels 3 and 4 mixed will be output. • When not linking the monitor audio output selection to the setting of the METER switch, select the desired channel (CH-1/CH-2/CH-3/CH-4).

Audio settings pages 2-1 to 4-3

Make settings in the same way as pages AU-2 to AU-4.

Making Settings in the Audio Settings Subpages

Use the audio settings subpages to make mix and swap input and output settings for channels 1 and 2.

To display the audio settings subpages

- 1 Press F1 to highlight the audio settings item in the home page.
- 2 If the item displayed is not “MIX/SWP,” press the UP button until “MIX/SWP” appears.

- 3 Press the PAGE button.

An audio settings subpage (input mixing page) appears as shown below.

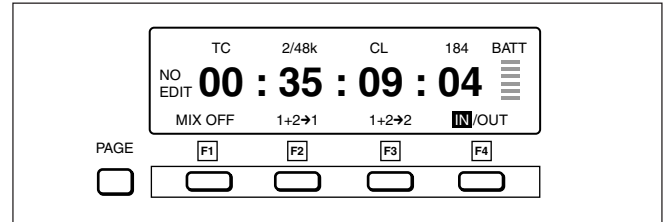

To switch pages

Press the F4 button.

An output monitor settings page like the one below appears.

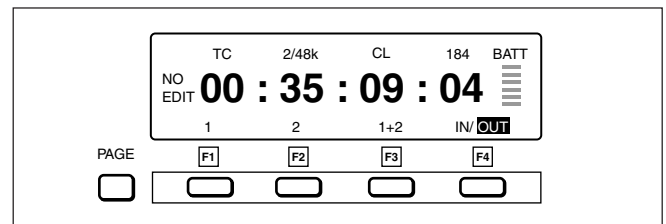

Each press of the F4 button switches between the input mixing settings page and the output monitor settings page.

To return to the home page

Press the PAGE button.

Contents of the audio settings subpages

When you change the settings of the audio settings subpages, the settings of the AU-1 page change as well, and vice versa.

However, when there is no item in the subpages corresponding to a setting made in the AU-1 page, the setting is not reflected in the subpages.

Input and Output Settings for Video and Audio Signals — Sub LCD Menu

Input mixing settings page

By pressing F1 to F3, you can make the following three settings for mixing of input signals in audio channels 1 and 2. The selected setting is highlighted. To select input signals, use audio settings page 1-2.

MIX OFF: Assign IN-1 to channel 1, and assign IN-2 to channel 2.

1+2 → 1: Assign mixed signals of IN-1 and IN-2 to channel 1, and assign IN-2 to channel 2.

1+2 → 2: Assign IN-1 to channel 1, and assign mixed signals of IN-1 and IN-2 to channel 2.

Output monitor settings page

By pressing F1 to F3, you can make the following three settings for monitor output signals. The selected setting is highlighted.

1: Assign channel 1 to monitor output.

2: Assign channel 2 to monitor output.

1+2: Assign mixed signals from channels 1 and 2 to monitor output. (This corresponds to the MONITOR item setting “METER” in audio settings page 1-3.)

Making Settings in the Video Settings Page

The following tables show the items that can be set in the video settings page.

Video settings page

MONITOR OUTPUT	PP MODE OFF	PP SIZE 1/9	PP POSI. 4
PROCESS CONTROL PANEL	WIDE AUTO	ZEBRA OFF	

Item	Setting
MONITOR ^{a)}	When composite video (CMPST) has been selected for input, select the E-E signal for output to the LCD monitor of the unit. INPUT: Input video E-E with no digital process delay is output. OUTPUT: Output video E-E with a digital process delay is output
PP MODE ^{a)}	Select how to display two input pictures on the LCD monitor. OFF: Not displaying two pictures. 1: Picture-in-picture display 2: Two pictures reduced and displayed side by side 3: Side-by-side display reduced in horizontal direction only
PP SIZE ^{a)}	Select the size of the smaller picture to be inset for picture-in-picture display on the LCD monitor. 1/16: 1/16 the normal size 1/9: 1/9 the normal size 1/4: 1/4 the normal size
PP POSI. ^{a)}	Select the position of the smaller picture to be inset for picture-in picture display on the LCD monitor. 1: Upper left position 2: Upper right position 3: Lower left position 4: Lower right position
PROCESS CONTROL	Select what to use to control the following items: SETUP (when using the setup menu) or PANEL (when using the front control section). • Video output level • Chroma signal output level • Setup level (DSR-70A)/black level (DSR-70AP) • Chroma phase
WIDE	Select whether to record/play back video with wide-screen aspect ratio information requiring the LCD monitor to switch to 16:9 mode. AUTO: The LCD monitor automatically switches to 16:9 mode when wide screen video is input or played back. ON: The LCD monitor is always in 16:9 mode. OFF: The LCD monitor does not switch to 16:9 mode.
ZEBRA	Set the zebra pattern to be displayed in the LCD monitor. OFF: Do not display. 50%: Display zebra pattern with 50% or more video level. 80%: Display zebra pattern with 80% or more video level. 100%: Display zebra pattern with 100% or more video level.

a) Displayed only when the DSBK-180/180P Dual Video Input Board is installed

General Settings Pages of the Sub LCD Menu

There are general settings pages (1) and (2).

General settings page (1)

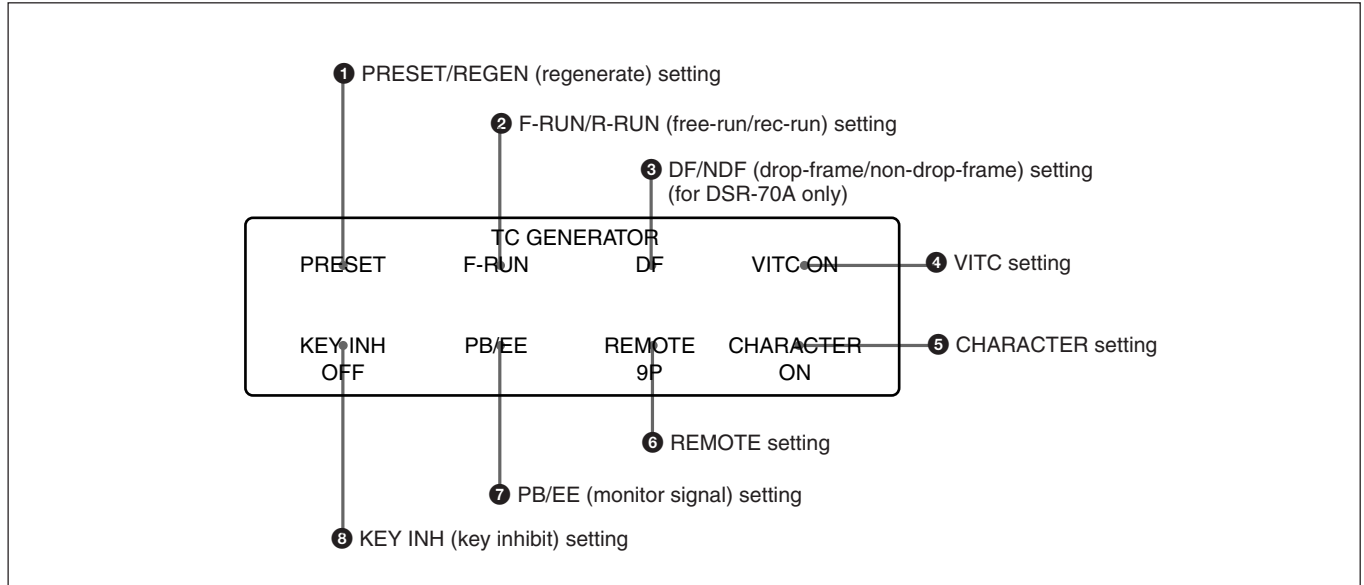

1 PRESET/REGEN (regenerate) setting

Select the value set in the internal timecode generator.

PRESET: Preset the initial value of the timecode generated by the internal timecode generator, either by a control panel operation or by remote control from the device connected to the REMOTE connector.

REGEN: Synchronize the internal timecode generator with the timecode read by the internal timecode reader.

2 F-RUN/R-RUN (free-run/rec-run) setting

Select the progression method for the timecode generated by the internal timecode generator.

F-RUN: Timecode progresses continuously from the time when this unit is powered on, regardless of the unit's operating status.

R-RUN: Timecode progresses only during recording.

3 DF/NDF (drop-frame/non-drop-frame) setting (for DSR-70A only)

Select DF to advance timecode in drop-frame mode, and NDF to advance timecode in non-drop-frame mode.

4 VITC setting

Set to ON to record the VITC timecode generated by the internal timecode generator.

When this is set to OFF, the internally generated VITC timecode is not recorded, but the VITC timecode inserted in the input video signal is recorded as it is.

5 CHARACTER setting

Set to ON to superimpose text information such as timecode, menu settings and alarm messages on the video signal output from the VIDEO OUTPUT 2 (SUPER) connector.

6 REMOTE setting

When the REMOTE/LOCAL switch is set to REMOTE, select the source for control of this unit.

9P: The unit is controlled from the device connected to the REMOTE connector (D-sub9-pin).

i.LINK: The unit is controlled from the device connected to the DV IN/OUT connector (DSBK-140/160A).

7 PB/EE (monitor signal) setting

Select the video/audio signal output when the tape is being fast forwarded or rewound, or when the unit is stopped or on standby.

PB: Playback signal

PB/EE: Input signal in E-E mode

General Settings Pages of the Sub LCD Menu

⑧ KEY INH (key inhibit) setting

Set to ON to disable the buttons on the control panel. (Sub LCD menu operations can still be performed even when this item is set to ON.)

You can select the buttons that are disabled under setup menu item 118.

If you try to operate the disabled buttons, the message “!!KEY INH.!” appears in the time data display area on the sub LCD.

To switch to general settings page (2)

Press the PAGE button.

General settings page (2)

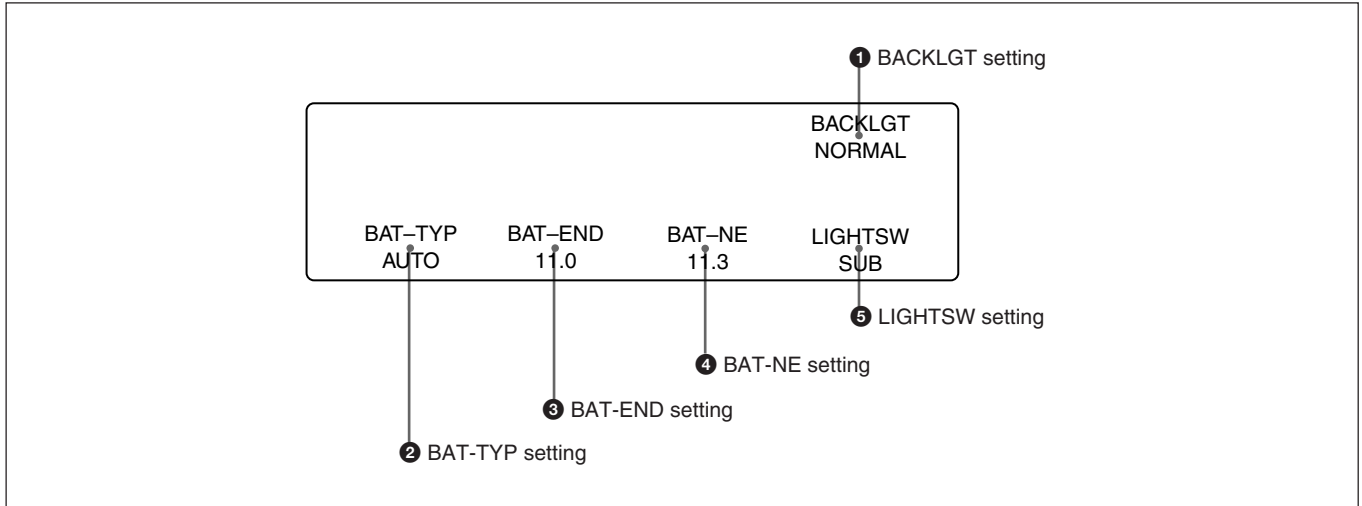

① BACKLGT (back light) setting

Set to HIGH to increase the brightness of the LCD monitor back light.

② BAT-TYP (battery type) setting

Set the type of the battery used.

AUTO: The battery type is automatically checked.

Ni: BP-90/90A

Li: BP-L60/L60A/L90/L90A

ANTON: Anton Bauer Magnum battery

Note

To use the Anton Bauer Magnum battery, you require a special battery mount to be attached to this unit.

For more information about the special battery mount, contact an Anton Bauer agent or your Sony dealer.

③ BAT-END (battery end) setting

Set a voltage value to indicate the shutdown voltage of this unit.

④ BAT-NE (battery near end) setting

For alarms that alert you when the end of power as specified in the battery end setting ③ is near, specify a voltage that at which to begin the alarm display.

⑤ LIGHTSW (backlight control switch) setting

Control the light power of the LCD monitor and sub LCD.

SUBMAIN: The both are controlled by the LIGHT switch.

MAIN: The LCD monitor backlight power is controlled by the LIGHT switch. The sub LCD backlight power is continually on.

SUB: The sub LCD backlight power is controlled by the LIGHT switch. The LCD monitor backlight power is continually on.

Editing

Sequence of Editing Operations

The following is a typical sequence of cut editing operations carried out using two DSR-70A/70AP units as a pair of player and recorder.

Sequence of Operations

Making necessary settings



Insert cassettes.

- Insert a cassette for recording the results of editing in the recorder.
- Insert the cassette on which material to be edited has been recorded in the player.



Select an edit mode.



Determine edit points.

- Preview edit results.
- Modify edit points, if necessary.



Execute an edit.

- Review the edit results.
- Redo the edit, if necessary.

See

“Settings for Editing” (page 74)

“Handling Cassettes” (page 37)

“Selecting an Edit Mode”
(page 77)

- “Finding Edit Points —Search” (page 79)
- “Setting Edit Points” (page 80)

“Executing an Edit” (page 84)

Settings for Editing

When using two units of the DSR-70A/70AP as a pair of recorder and player in an editing system, set the recorder and player as follows. Basically, the same recorder settings and player settings apply when you use a DSR 70A/70AP unit as a stand-alone recorder or player.

Recorder Settings

Make settings as follows.

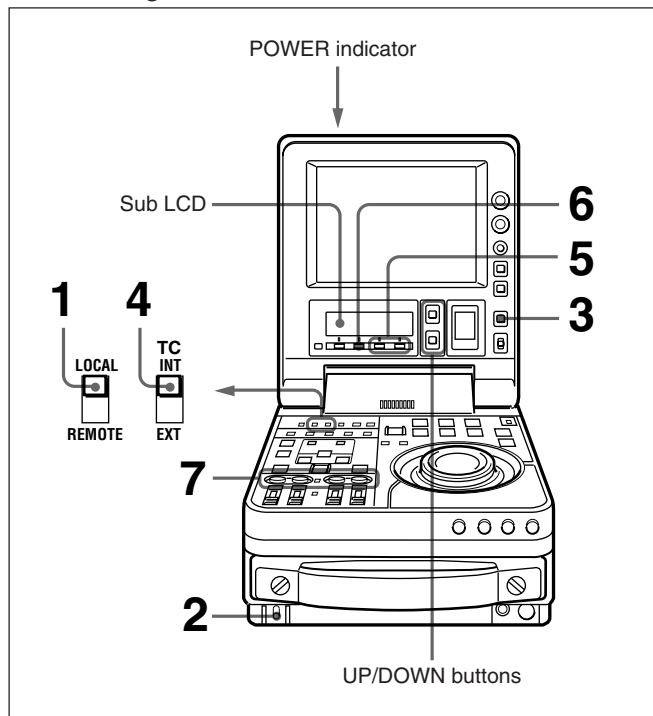

1 Set the REMOTE/LOCAL switch to LOCAL.

2 Set the POWER switch to ON, then make the following checks.

When the unit is powered, the POWER indicator lights and the sub LCD home page appears in the sub LCD.

Check	Indication/What to do	See for details
Enough battery power remaining?	Check the remaining battery power indication. If "BATT" is flashing Replace the battery.	" 6 Remaining battery power indication" (page 65)
No condensation in the unit?	If "HUMID!" is displayed Leaving the unit powered, wait until the message disappears. (In this case, the alarm message "MOISTURE HAS BEEN DETECTED" also appears on the LCD monitor.)	"Condensation" (page 135)

3 Use the COUNTER SELECT button to select the type of time data to be used.

Each press of the button cycles through three options in the sub LCD: CNT, TC, and UB.

Selectable time data	Time data indication in the sub LCD
Count in the counter	CNT
Timecode	TC
User bit data	UB

4 When the time data selected in step **3** is timecode (TC), use the TC INT/EXT switch to select the type of timecode.

Selectable timecode	TC INT/EXT switch setting
Timecode generated by the internal timecode generator	INT
External timecode input to the TC IN connector	EXT

5 Select the formats of video and audio input signals to be used.

If any signal not connected to the unit is selected, the corresponding signal indication in the sub LCD flashes.

To select an input video signal format

Press the sub LCD operation button F4, highlighting the input video signal indication, then press the UP button or the DOWN button repeatedly until the input video signal indication corresponding to the desired video signal appears in the sub LCD.

Selectable video signals (Input connectors)	Input video signal indication in the sub LCD
Composite signals (VIDEO INPUT)	CMPST
S-video signal (S VIDEO IN)	S VIDEO
i.LINK (DV) signals (DV IN/OUT (optional DSBK-140/160A))	i.LINK
SDTI (QSDI) signals (SDTI(QSDI) IN (optional DSBK-150))	SDTI
SDI signals (SDI IN (optional DSBK-160A))	SDI
Component signals (Y, R-Y, B-Y (optional DSBK-170))	CMPNT ^{a)}
Test video signal	SG

a) When using the component signals (CMPNT), set the IN/OUT switch of the DSBK-170 to IN.

Selecting the i.LINK (DV) or SDTI (QSDI) signals for input video causes the same to be automatically selected also for input audio.

To select an input audio signal format

Press the sub LCD operation button F3, highlighting the input audio signal indication, then press the UP button or the DOWN button repeatedly until the input audio signal indication corresponding to the desired audio signal appears in the sub LCD.

Selectable audio signals (Input connectors)	Input audio signal indication in the sub LCD
Analog signals (AUDIO INPUT CH-1/CH-2)	ANALOG
i.LINK (DV) signals (DV IN/OUT (optional DSBK-140/160A))	i.LINK
SDTI (QSDI) signals (SDTI(QSDI) IN (optional DSBK-150))	SDTI
SDI signals (SDI IN (optional DSBK-160A))	SDI
Test audio signal	SG

Selecting the i.LINK (DV) or SDTI (QSDI) signals for input audio causes the same to be automatically selected also for input video.

- 6** Select the audio recording mode. Press the sub LCD operation button F2, highlighting the audio recording mode indication, then press the UP button or the DOWN button so that the audio recording mode indication corresponding to the selected mode appears in the sub LCD.

Selectable audio recording mode	Indication in the sub LCD
Two-channel, 48-kHz recording mode	2/48k
Four-channel, 32-kHz recording mode	4/32k

Notes

- In the DVCAM format, there are two audio recording modes, that is, two channel, 48-kHz mode and four-channel, 32-kHz mode. It is not possible to select other modes (for example, four-channel, 48-kHz mode).
- If an audio signal in a different mode than the base tape is used in assemble or insert editing, the signals will be discontinuous at the edit points and correct editing will not be obtained. For this reason, audio editing between different modes is inhibited on this unit.
For smooth editing operations, check the audio recording mode of the base tape beforehand. If on a tape there is a point where the audio mode is switched, you cannot perform an insert editing on that point.
- Once you have started recording, you cannot change the audio mode selection.

- 7** Use the AUDIO INPUT PRESET/VARIABLE switch and the AUDIO INPUT CH 1 to CH-4 level adjustment knobs to adjust the audio input levels. Watching the audio level meter, adjust the levels so that the meter does not indicate higher values than 0 dB when the audio signals are at their maximum.

AUDIO INPUT PRESET/VARIABLE switch setting	Audio input level adjustment
PRESET	Preset to fixed levels. Levels cannot be adjusted with the level adjustment knobs.
VARIABLE	Levels adjustable with the level adjustment knobs. Adjust the levels while viewing the audio level meter in E-E mode.

Settings for Editing

Player Settings

Make settings as follows.

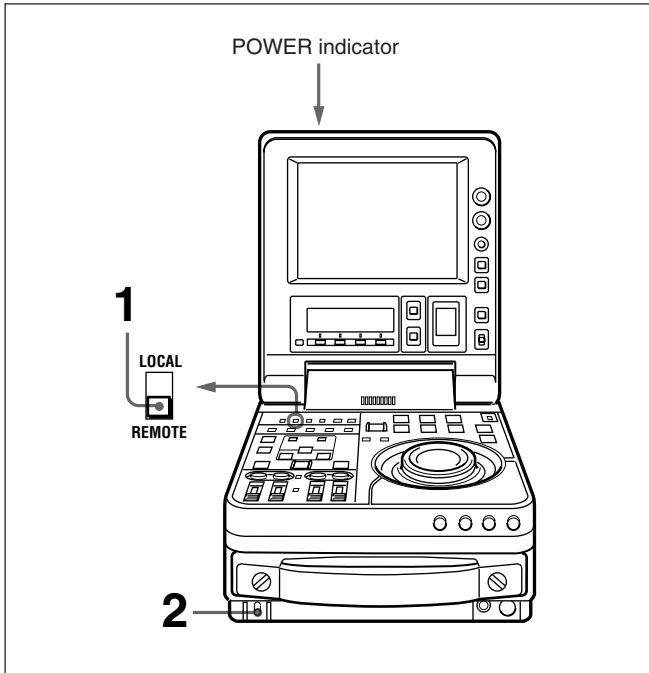

- 1 Set the REMOTE/LOCAL switch to REMOTE.
- 2 Set the POWER switch to ON, then make the following checks.

When the unit is powered, the POWER indicator lights and the sub LCD home page appears in the sub LCD.

Check	Indication/What to do	See for details
Enough battery power remaining?	<p>Check the remaining battery power indication.</p> <p>If “BATT” is flashing Replace the battery.</p>	<p>“6 Remaining battery power indication” (page 65)</p>
No condensation in the unit?	<p>If “HUMID!” is displayed Leaving the unit powered, wait until the message disappears. (In this case, the alarm message “MOISTURE HAS BEEN DETECTED” also appears on the LCD monitor.)</p>	<p>“Condensation” (page 135)</p>

Selecting an Edit Mode

When you use two DSR-70A/70AP units, you can do two types of editing: assemble editing and insert editing. This section provides an outline of each type and explains how to select an edit mode.

In the subsequent explanation of editing operations in this chapter, illustrations of a pair of DSR-70A/70AP units (player and recorder) combined using the optional BKNW-225 Docking Kit are used (*see page 132*). In each illustration, as viewed from the front, the unit on the left is the player and the unit on the right is the recorder.

Assemble Editing

In assemble editing, you record video and audio materials in order from the start of the tape. In addition to video and audio, timecode is also recorded. If timecode is already recorded on the tape, the new timecode is recorded so as to form a continuous sequence with the existing timecode.

Assemble editing is convenient when you are recording on a new tape.

Note

Before you begin assemble editing for the first time with a new tape, video signal such as black signal and timecode must be recorded on the tape in advance of the recorder IN point for a length equal to or greater than the preroll time.

Selecting assemble mode

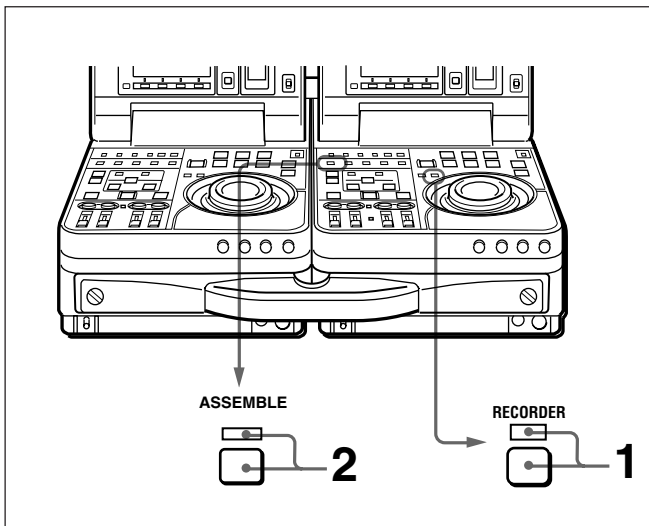

- 1 Press the RECORDER button on the recorder control panel.

The RECORDER indicator lights.

- 2 Press the ASSEMBLE button on the recorder control panel.

The ASSEMBLE indicator lights.

To cancel assemble mode

Press the ASSEMBLE button again to turn the ASSEMBLE indicator off.

Insert Editing

In insert editing, you insert video, audio, and timecode at desired positions on an already recorded tape. You can insert all three types of data at the same time, or insert one of the types separately.

Note

Before you use an unrecorded tape in insert editing, video signal such as black signal and timecode must be recorded on all over the tape.

Selecting insert mode

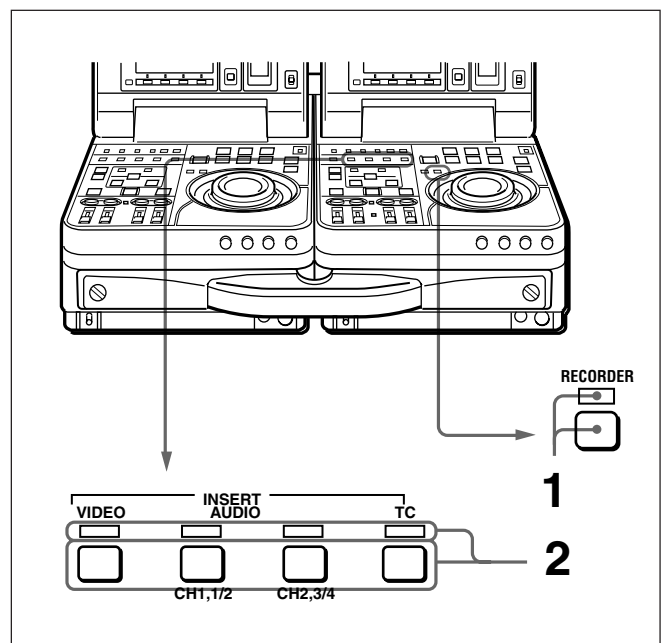

Selecting an Edit Mode

- 1** Press the RECORDER button on the recorder control panel.

The RECORDER indicator lights.

- 2** Press one or more of the INSERT buttons on the recorder control panel to select the signals you want to insert.

The corresponding INSERT indicators light.

To cancel the selection of a signal

Press the corresponding INSERT button again to turn the corresponding indicator off. Selection of a signal is canceled when its indicator goes out.



Finding Edit Points —Search

Playback in search mode using the jog and shuttle dials allows finding edit points quickly.

Jog mode

Playback speed is determined by the rotation speed of the jog dial between ± 1 times normal speed. Rotate the dial in the clockwise direction to search in the forward direction, and rotate the dial in the counterclockwise direction to search in the reverse direction.

Shuttle mode

Playback speed is determined by the rotation angle of the shuttle dial between ± 32 times normal speed (23 steps) (the setting can be changed using setup menu item 102). Click points allow playback at ± 5 times normal speed.

Rotate the dial in the clockwise direction to search in the forward direction, and rotate the dial in the counterclockwise direction to search in the reverse direction.

Variable speed mode

Playback speed is determined by the rotation angle of the shuttle dial in the range of -1 to $+2$ times normal speed (54 steps). Rotate the dial in the clockwise direction to search in the forward direction, and rotate the dial in the counterclockwise direction to search in the reverse direction.

In the range of $\pm 1/2$ times normal speed, you can carry out noiseless playback.

Switching between each mode

Lighting the JOG or SHUTTLE indicator shows the corresponding mode is selected. Lighting both the JOG and SHUTTLE indicators shows the variable speed mode is selected.

Switching from jog to shuttle mode

Rotate the shuttle dial.

Switching from shuttle or variable speed to jog mode

Press the jog dial or rotate the jog dial while setting the shuttle dial at still position.

Switching from shuttle or jog to variable speed mode

Press the search button for 1 or more seconds.

Switching from variable speed to shuttle mode

Press the search button for 1 or more seconds.

To switch between normal playback and search modes

Press the PLAY and search buttons alternately.

As factory default setting, rotating the jog or shuttle dial switches to search mode at any time except during recording and editing.

If you change the setting of setup menu item 101, the above function will be disabled and switching to search mode will be possible only when the search button is pressed.

For details about setting, see item 101 (page 109).

Setting Edit Points

In editing operations, there are four edit points: an IN point and an OUT point on the recorder side, and an IN point and an OUT point on the player side. As soon as you set three of the edit points, the fourth edit point is calculated automatically.

In insert editing, you can set IN points for audio separately from the IN points for video (audio split editing).

For details, see “To set audio IN points separately from video IN points (audio split editing)” (page 81).

Note

If it is necessary to operate the buttons or dial on the player, set setup menu item 006 “LOCAL FUNCTION ENABLE” to ENA beforehand (see page 104).

Setting Edit Points

Proceed as follows to set edit points.

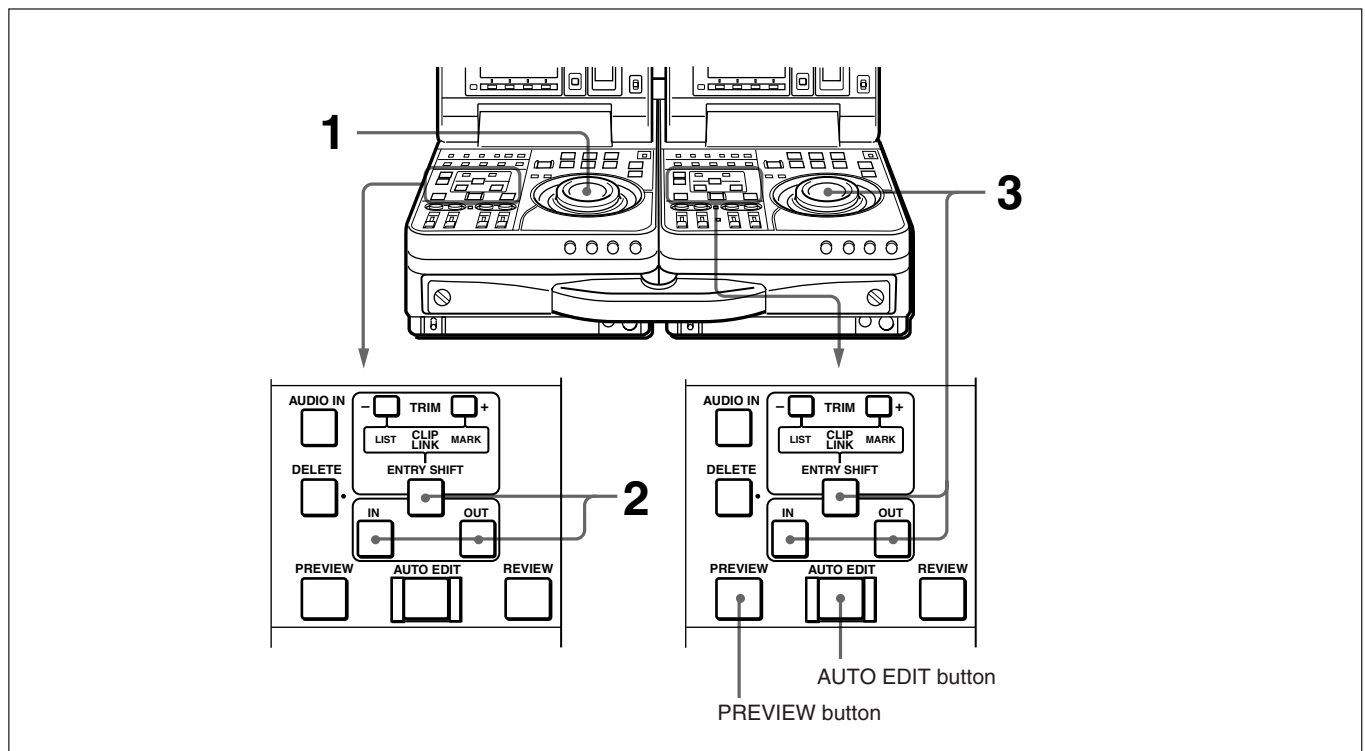

- 1 Rotate the player side jog or shuttle dial to find the player edit points.

For details about jog/shuttle dial operations, see “Finding Edit Points — Search” (page 79).

- 2 Press the IN button together with the ENTRY/SHIFT button at the point you want to set as the IN point. Press the OUT button together with the ENTRY/SHIFT button at the point you want to set as the OUT point.

The IN and OUT points are set, and the IN and OUT buttons light.

- 3 Repeat steps 1 and 2 on the recorder side to set the recorder IN or OUT point.

As soon as you set three edit points on the player and recorder, the PREVIEW button and the AUTO EDIT button light to indicate that you can conduct a preview or edit.

Note

If you set four or more edit points on the player and recorder, the DELETE button flashes. You cannot conduct an edit when the unit is in this state. Delete the unneeded edit points.

For details, see “Modifying Edit Points” (page 83).

To set audio IN points separately from video IN points (audio split editing)

In insert editing, press the AUDIO IN button together with the ENTRY/SHIFT button at the point you want to set as the audio IN point. The audio IN point is set and the AUDIO IN button lights.

Checking Edit Points

You can check the time data of edit points and the duration between two edit points by displaying them in the sub LCD.

To display the time data of edit points

Press the recorder side or player side IN or OUT button.

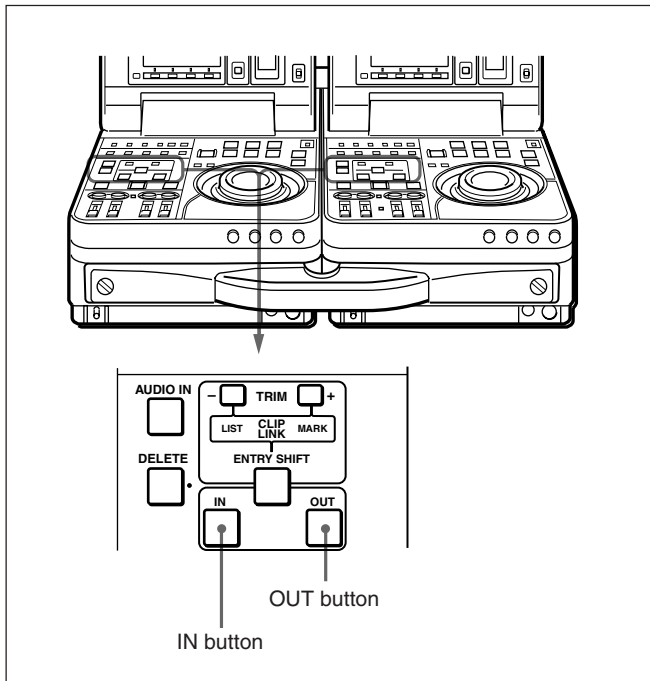

While the button remains pressed, the time data for the corresponding edit point is displayed in the sub LCD.

To display the duration between two edit points

From among the recorder side and player side IN buttons (or AUDIO IN buttons) and OUT buttons, press two of the buttons together. The duration appears in the sub LCD while the buttons are kept pressed. In some cases, negative durations preceded by a minus sign (-) may be displayed.

The displayed durations are calculated as follows.

When two edit points are set: The duration between the two edit points

When only one edit point is set: The duration between the edit point and the current tape position

When no edit points are set: The duration of the most recently set edit points

Cuing Up Edit Points

You can cue up any edit point, or cue up a position located a specified amount of time before the edit start point (preroll).

To set the preroll time

Using the setup menu item 001, specify how many seconds (the preroll time) in advance of the edit start point to set the preroll point. The factory default preroll time is 5 seconds.

For details, see page 104.

Use the following procedures to cue up an edit point or preroll the tape.

Setting Edit Points

To cue up an edit point

Press and hold the recorder side or player side IN or OUT button, and press the recorder or player PREROLL button while holding the IN or OUT button.

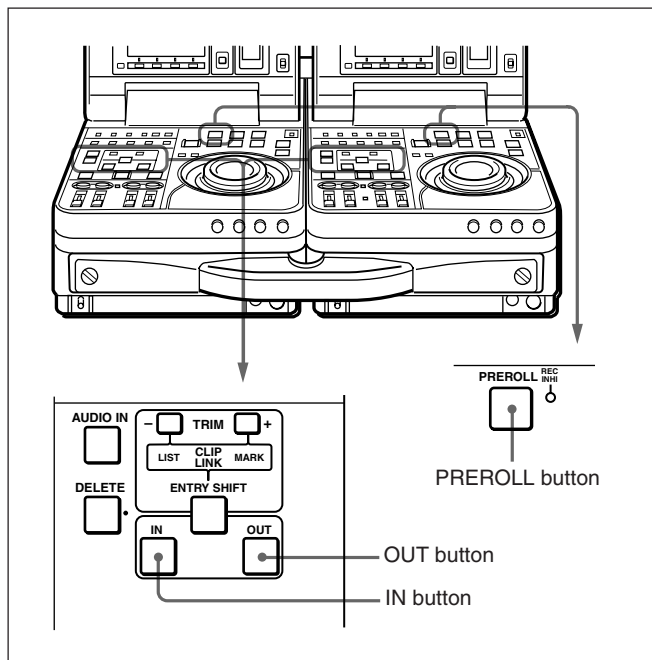

The tape runs to the IN point or OUT point and stops.

To preroll the tape

Press the recorder side or player side PREROLL button.

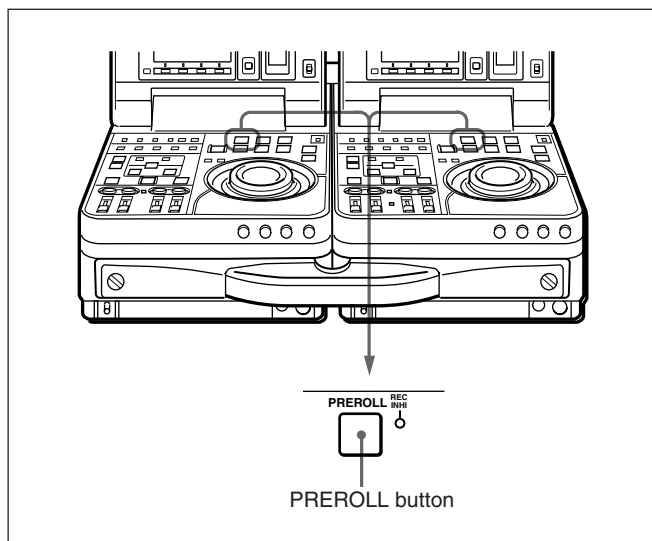

The tape runs to the preroll point, located in advance of the edit start point by the specified amount of time, and then stops.

Previewing Edit Results

When you finish setting the edit points, the PREVIEW button flashes to indicate that you can conduct a preview.

To conduct a preview, press the recorder side PREVIEW button, turning it on.

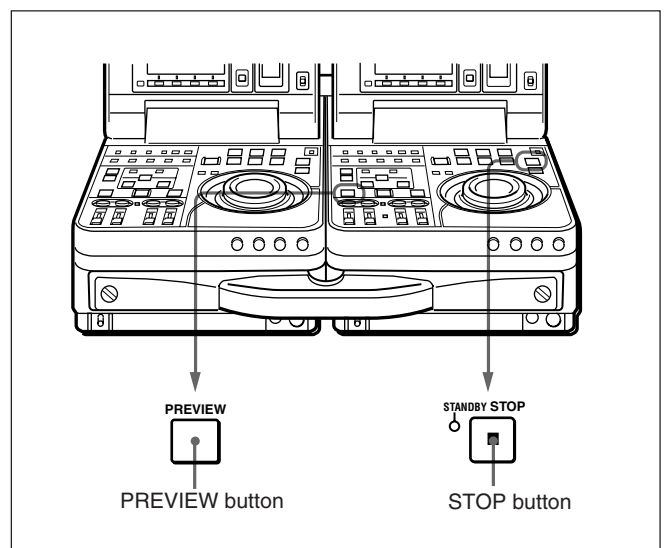

During the preview, you can see the video in the recorder side LCD monitor and listen to the audio through the recorder side speaker. The figure below shows the video and audio signals which can be monitored.

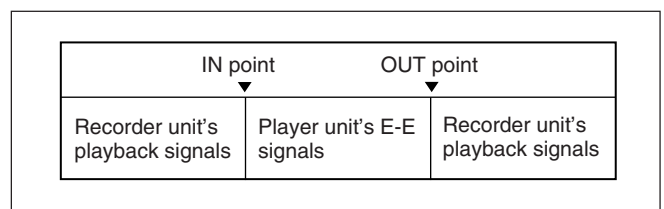

After the preview, modify, delete, or reset edit points as required.

For more information about modifying edit points, see "Modifying Edit Points" (page 83).

To stop a preview

Press the STOP button on the recorder. The tape stops when the button was pressed.

Modifying Edit Points

Once you set edit points, you can delete them or modify them as required in units of one frame. When edit points have been set incorrectly, for example when an OUT point is located before an IN point or when the durations of editing segments on the player and recorder do not match, the DELETE buttons flash to alert you that a preview or edit cannot be conducted. Correct the edit points as required.

To delete an edit point

Proceed as follows.

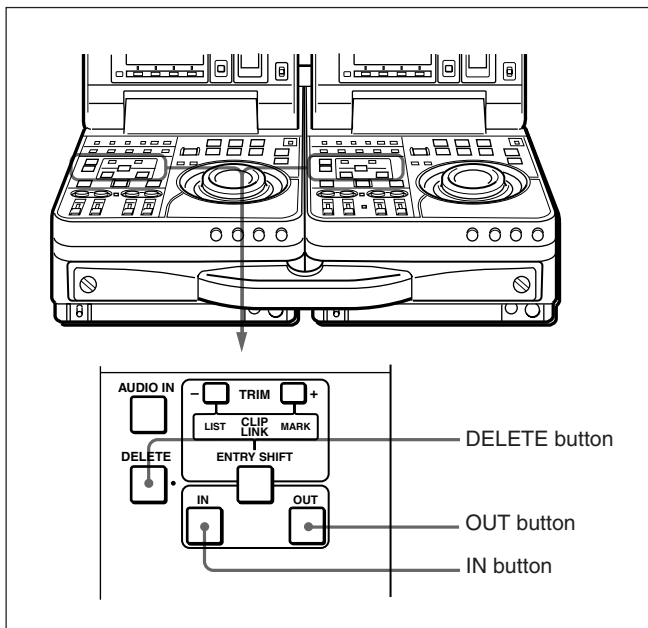

Press the flashing DELETE button together with the IN button or the OUT button. The DELETE button stops flashing, and the edit point is deleted.

To modify edit points slightly

Proceed as follows.

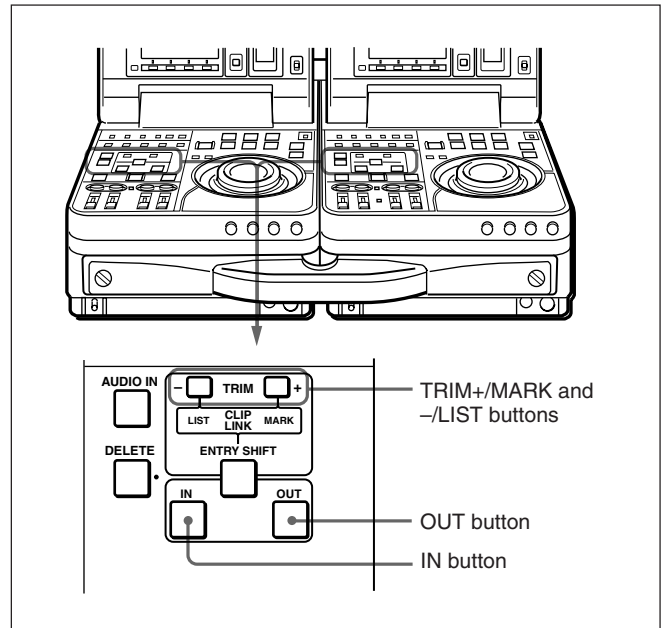

- 1 While pressing the recorder side or player side IN or OUT button, depending on the edit point that you want to modify, press a TRIM button (+/MARK or -/LIST) on the same side of the control panel.

The edit point time data is displayed. Each time you press the +/MARK button, you advance one frame, and each time you press the -/LIST button you return one frame.

- 2 After making the modifications, press the IN or OUT button that you pressed in step 1.

Setting Edit Points Using the Recorder Only

If you press the PLAYER/DMC button to light the PLAYER/DMC indicator on the control panel, you can operate the player or an external VCR with the recorder side buttons, and set edit points. In this case, it is recommended that you set setup menu item 006 “LOCAL FUNCTION ENABLE” to ST&EJ (default setting) on the player beforehand (see page 104).

Executing an Edit

Outline of Editing Operations

The figure below shows how the recorder and player operate during edit.

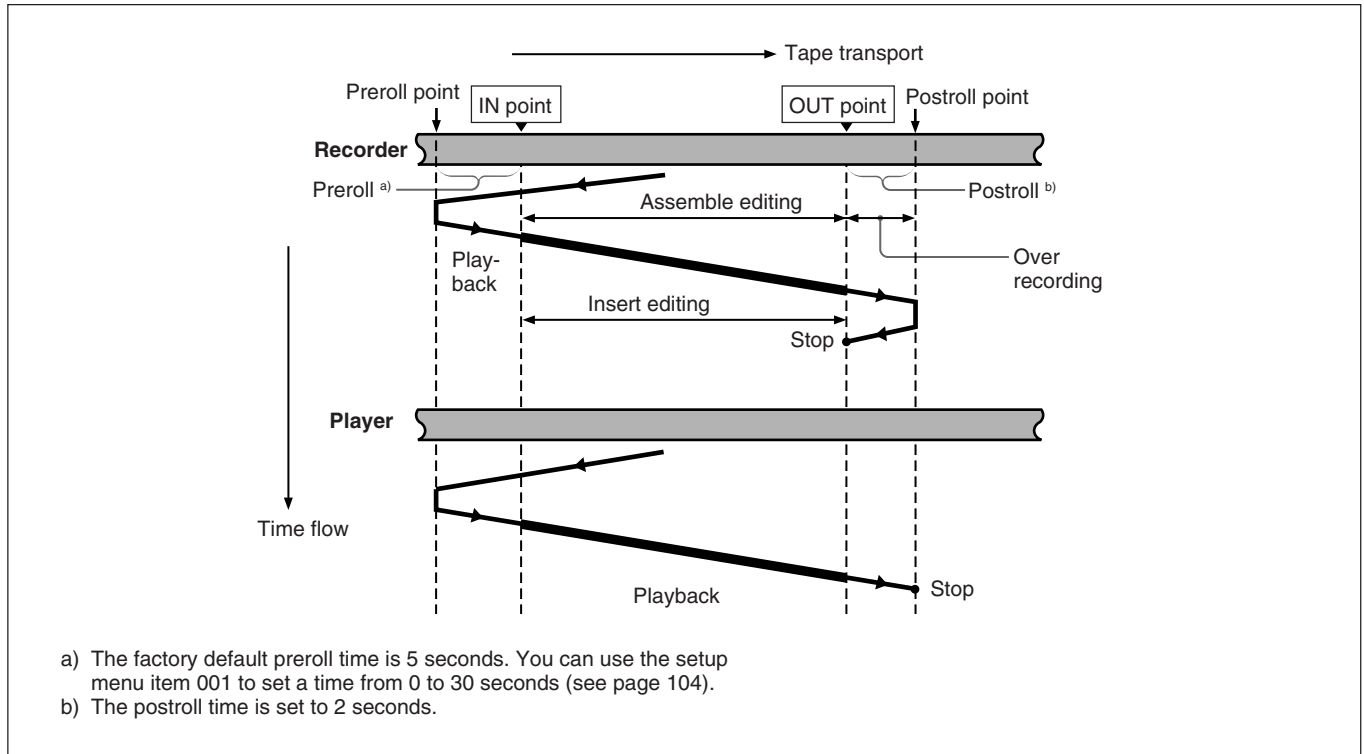

Monitoring signals during an edit

Just as during a preview, you can see the video in the recorder side LCD monitor and listen to the audio through the recorder side speaker.

The figure below shows the video and audio signals which can be monitored.

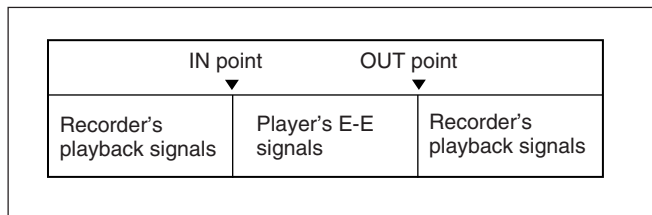

Note

For insert editing, the tape set on the recorder must be a recorded one. You cannot perform insert editing on a blank tape.

Starting an Edit

To start an edit, press the AUTO EDIT button.

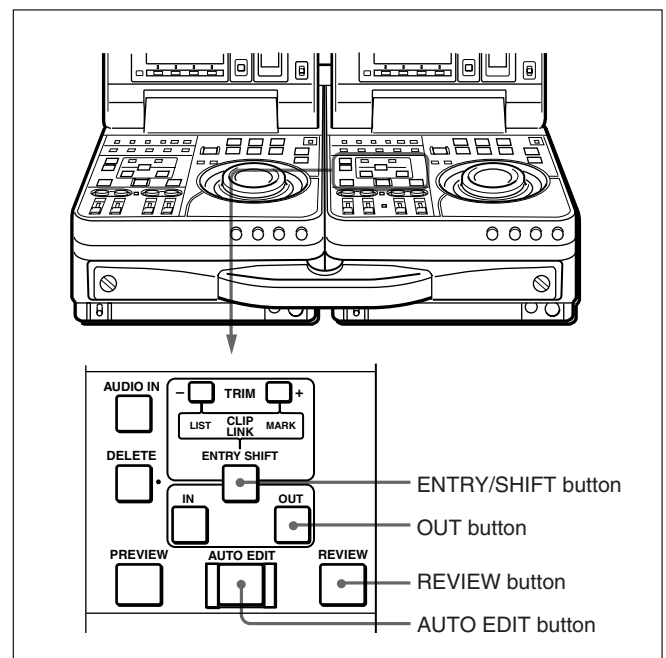

The AUTO EDIT button is lit during an edit. It goes out when the edit finishes.

To stop an edit

Press the ENTRY/SHIFT button together with the OUT button.

The edit ends, and the point where you pressed the buttons becomes the OUT point.

To abort an edit

Press the STOP button on the recorder.

To review the edit results

Press the REVIEW button.

When the review ends, the tape returns to the OUT point and stops.

Redoing an Edit

Edit point data used in up to the last ten edit executions are retained. You can modify the retained edit point data and redo the edits.

To modify the edit point data for the last edit executed and redo the edit

Perform the following procedure.

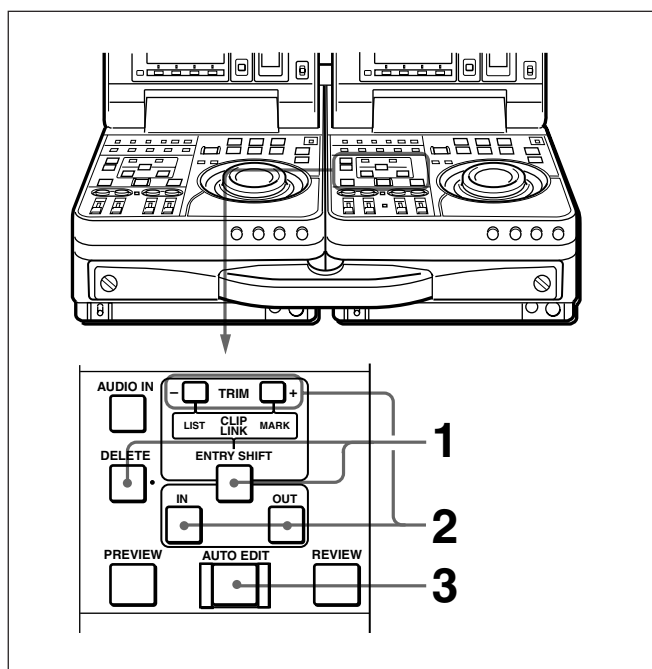

1 Press the recorder side DELETE button together with the ENTRY/SHIFT button.

2 Modify the edit points.

See "To Modify edit points slightly" (page 83) for the procedure.

3 Press the AUTO EDIT button.

The edit is redone.

To modify the edit point data for any of the last ten edits executed and redo the edit

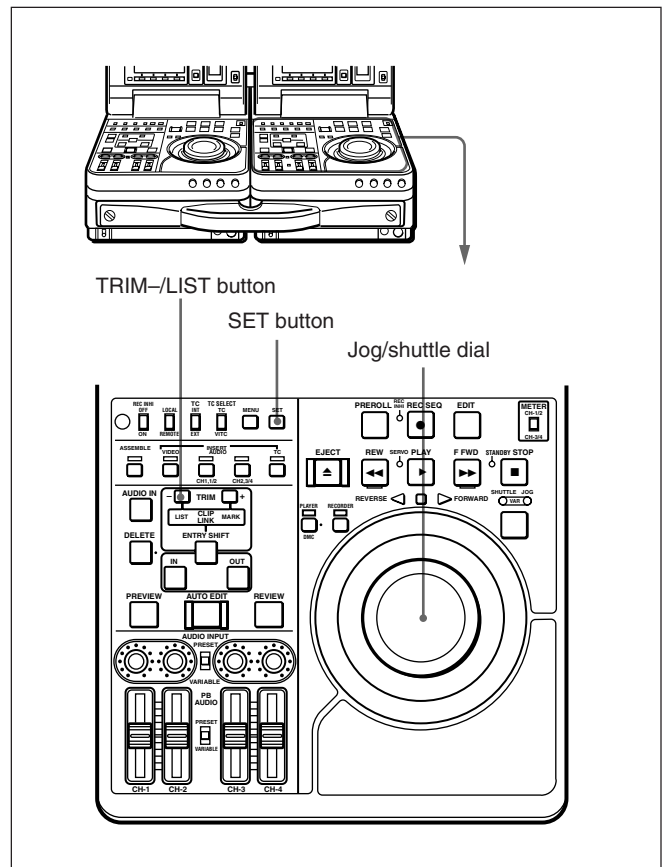

You can display the list of edit point data (edit list) for up to the last ten edits executed to modify the data and redo the edits as required.

Executing an Edit

To display the edit list

Press the TRIM-/LIST button.

The edit list appears on the LCD monitor.

You can scroll the edit list by rotating the jog/shuttle dial.

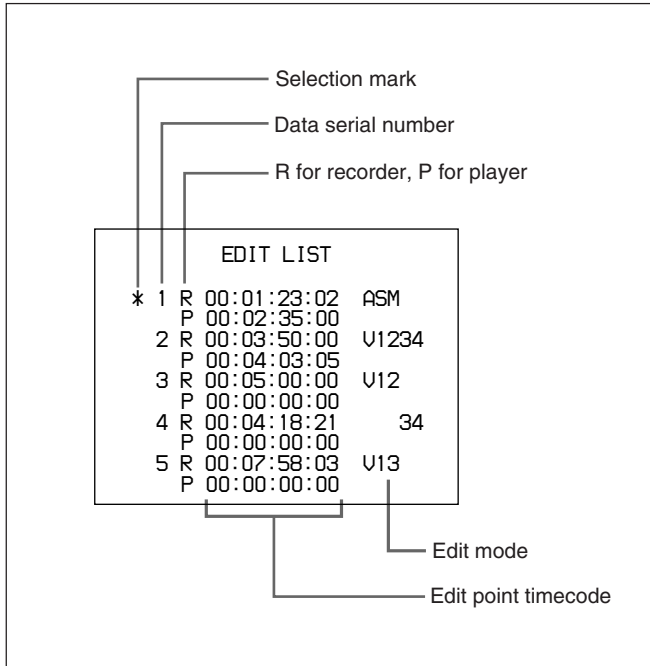

To exit from the edit list and return to the original LCD monitor display, press the TRIM-/LIST button again.

To display detailed data

To display detailed data relevant to the data serial number selected on the edit list, press the search button.

A detailed data list as shown in the following is displayed while the search button is held.

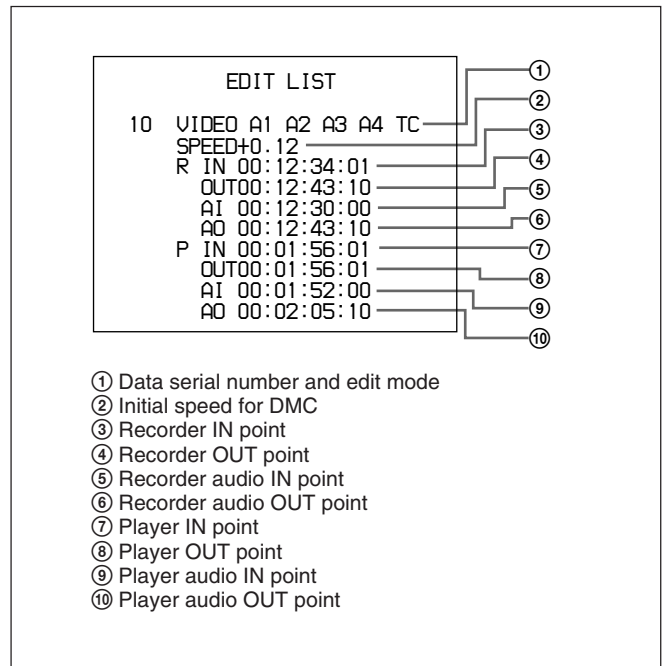

- ① Data serial number and edit mode
- ② Initial speed for DMC
- ③ Recorder IN point
- ④ Recorder OUT point
- ⑤ Recorder audio IN point
- ⑥ Recorder audio OUT point
- ⑦ Player IN point
- ⑧ Player OUT point
- ⑨ Player audio IN point
- ⑩ Player audio OUT point

Notes

- The initial speed for DMC is displayed only when DMC editing is carried out.
- The audio IN and OUT points are not displayed unless they are set.
- The player edit points are displayed only when two units (recorder and player) are used.

To modify the data selected on the edit list and redo the edit

After displaying the edit list, proceed as follows.

- 1 Turn the jog/shuttle dial to move the selection mark (*) on the edit list to the line displaying the data to be modified.
- 2 Press the SET button.

The edit mode, edit points and, if the edit involves DMC, the initial speed for DMC of the edit selected in step 1 are recalled allowing them to be modified.

- 3 Modify the data as required.
- 4 Redo the edit.

The data on the edit redone is added to the end of the edit list.

Setting Edit Points and Playback Speeds

Perform the following procedure.

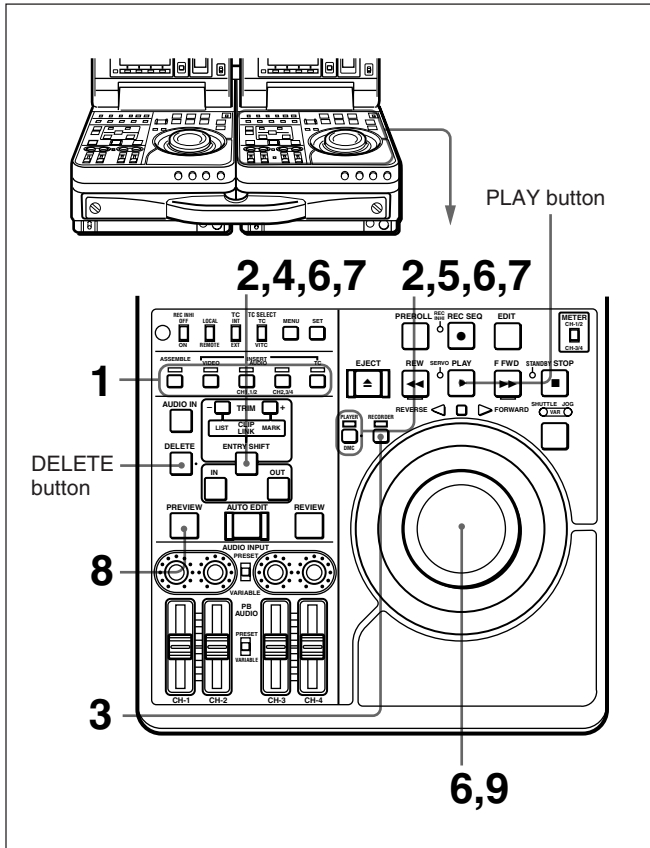

- 1** Press the ASSEMBLE or INSERT button to select edit mode.
- 2** Press the PLAYER/DMC button together with the ENTRY/SHIFT button.
The PLAYER/DMC indicator flashes and the unit enters DMC edit mode.
When the playback speed is stored in memory, the indicator flashes one time per second. When not, it flashes four times per second.

To exit DMC edit mode

Press the PLAYER/DMC button together with the DELETE button.

- 3** Press the RECORDER button.

The RECORDER indicator flashes.

- 4** To set edit points, press the ENTRY/SHIFT button together with the IN or OUT button.

- 5** Press the PLAYER/DMC button and set the IN point for the player.

Note

You cannot set an OUT point for the player.

- 6** Set the initial playback speed by rotating the shuttle dial while holding down the PLAYER/DMC button together with the ENTRY/SHIFT button.
If you wish to set the initial speed to normal speed, press the PLAY button.

The set speed is shown in the sub LCD.

- 7** Once the initial speed has been set, release the PLAYER/DMC button and ENTRY/SHIFT button.

- 8** Press the PREVIEW button.

The tape is prerolled. The recorder tape runs at normal speed and the player tape runs at its initial speed.

- 9** When the search button starts to flash, indicating that the tape has reached the IN point, rotate the shuttle dial to the position corresponding to the desired playback speed.

The variations in playback speed are stored into memory while the search button is flashing. When the tape passes the OUT point, the search button goes out.

If the JOG/SHUTTLE indicator goes out before the tape passes the OUT point

The unit cannot store any more variations in playback speed. The capacity of the playback speed memory is 120 seconds.

To amend the stored speed variation

Press the PREVIEW button.

The interval between the speed variation start and end points is automatically played back at the stored speed. Operate the search dial as required to adjust the playback speed.

To redo the storing of speed variation

Holding down the ENTRY/SHIFT button and PLAYER/DMC button, press the PREVIEW button. This erases the speed variation data stored in step **9** of the foregoing procedure. You can then redo step **9** of the procedure.

Executing DMC editing

Press the AUTO EDIT button.

DMC editing is executed at the playback speed(s) stored in memory.

Once the DMC edit has been completed, the playback speed(s) in memory are cleared.

To confirm the results of the edit

Press the REVIEW button.

Special Editing

This section explains the following kinds of editing.

- Quick editing
- Continuous editing
- Manual editing

In the subsequent explanation of operations in this

chapter, illustrations of a pair of DSR-70A/70AP units (player and recorder) combined using the optional BKNW-225 Docking Kit are used (*see page 132*). In each illustration, as viewed from the front, the unit on the left is the player and the unit on the right is the recorder.

Quick Editing

After selecting the edit mode, you can work more efficiently by using quick editing, which allows you to

set edit points and preview at the same time. Proceed as follows.

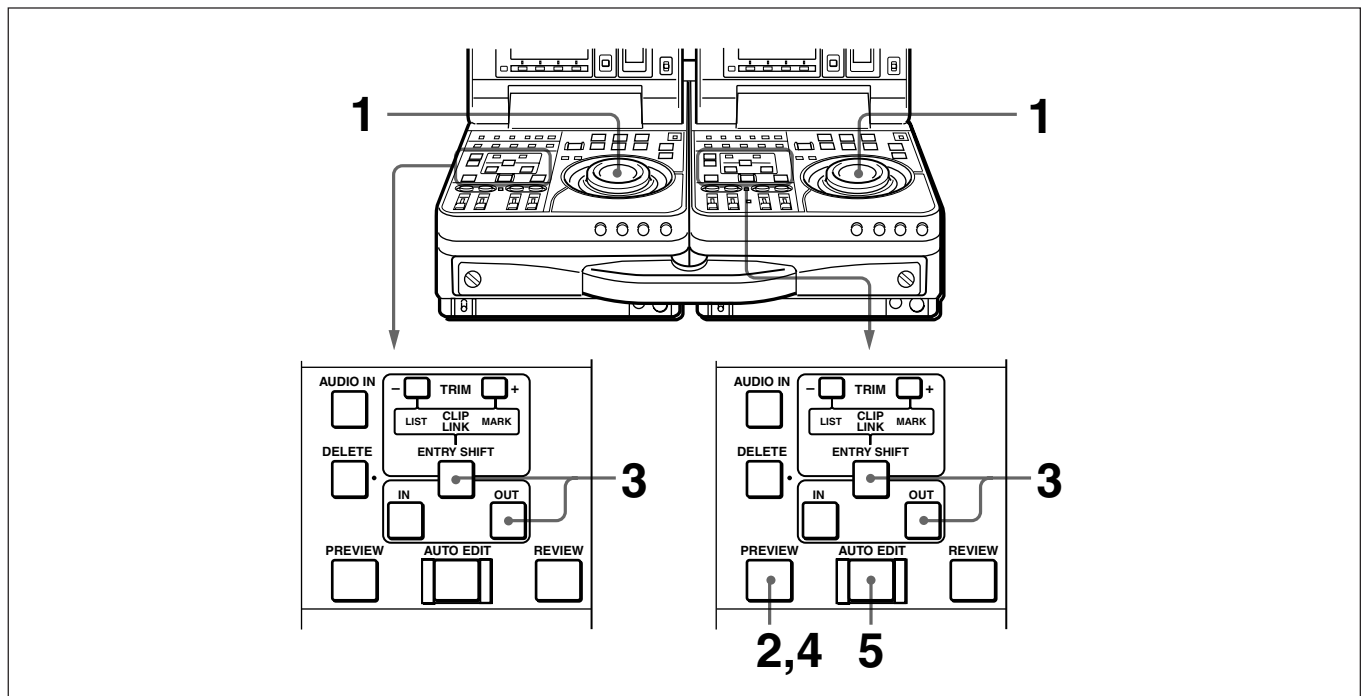

1 Stop the tapes at the points where you want to set the recorder side and player side IN points.

2 Press the recorder side PREVIEW button.

A preview starts. The points selected in step **1** are set as the IN points, and the IN buttons of the recorder and player light.

3 While monitoring the player video and audio, at the point where you want to set the OUT point, press the recorder side or player side OUT button together with the ENTRY/SHIFT button.

The OUT point is set, and the OUT button that you pressed lights.

Note

Setting an OUT point while viewing the recorder video and audio will shift the OUT point due to the time taken by digital processing (process delay) carried out on the recorder side.

4 Conduct another preview and modify the edit points as required.

5 Press the AUTO EDIT button.

The edit starts.

When the edit finishes, the recorder stops at the OUT point and player stops about 2 seconds after the OUT point.

To edit even more quickly

- 1 Stop the tapes at the points where you want to set the recorder side and player side IN points.
- 2 Press the AUTO EDIT button.

The edit starts.

- 3 While monitoring the player video and audio, when you reach the point you want to set as the OUT point, press the player side or recorder side OUT button together with the ENTRY/SHIFT button.

The point where the edit started is set as the IN point, and the point where the pressed the OUT and ENTRY/SHIFT buttons is set as the OUT point.

Continuous Editing

When you execute multiple edits in succession, you can edit from the second time on by setting the IN and OUT points of the player side only.

After execution of an edit, the recorder returns automatically to the OUT point. Therefore, the recorder side OUT point of the current edit becomes the IN point of the next edit.

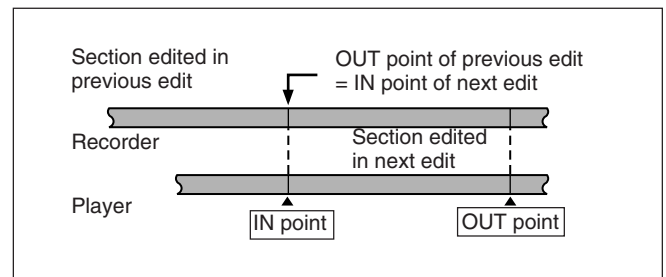

Use the following procedure.

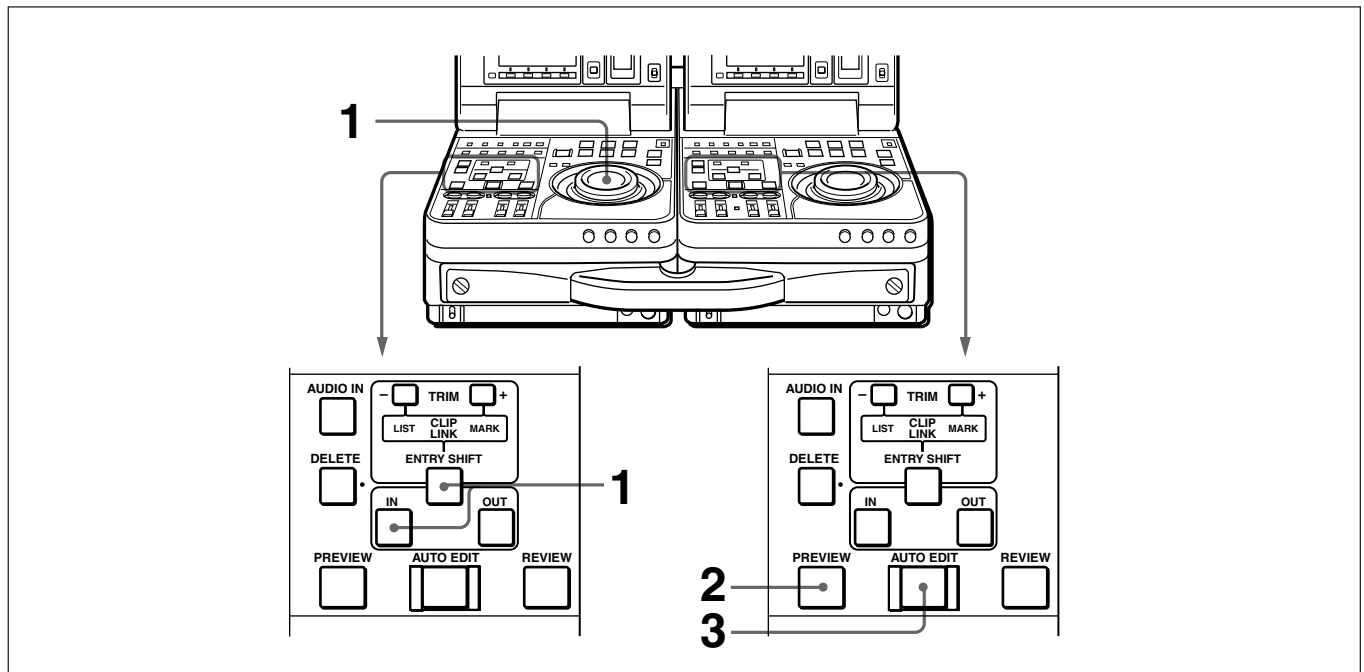

- 1 Set the player side IN point.
- 2 Press the recorder side PREVIEW button to conduct a preview.

- 3 Press the AUTO EDIT button.

The edit starts.

When the edit ends, the recorder stops at the OUT point and player stops 2 seconds after the OUT point.

Special Editing

To stop an edit

Press the ENTRY/SHIFT button together with the OUT button.

The edit ends, and the point where you pressed the buttons becomes the OUT point.

To abort an edit

Press the STOP button on the recorder.

Manual Editing

Perform manual editing using the recorder.

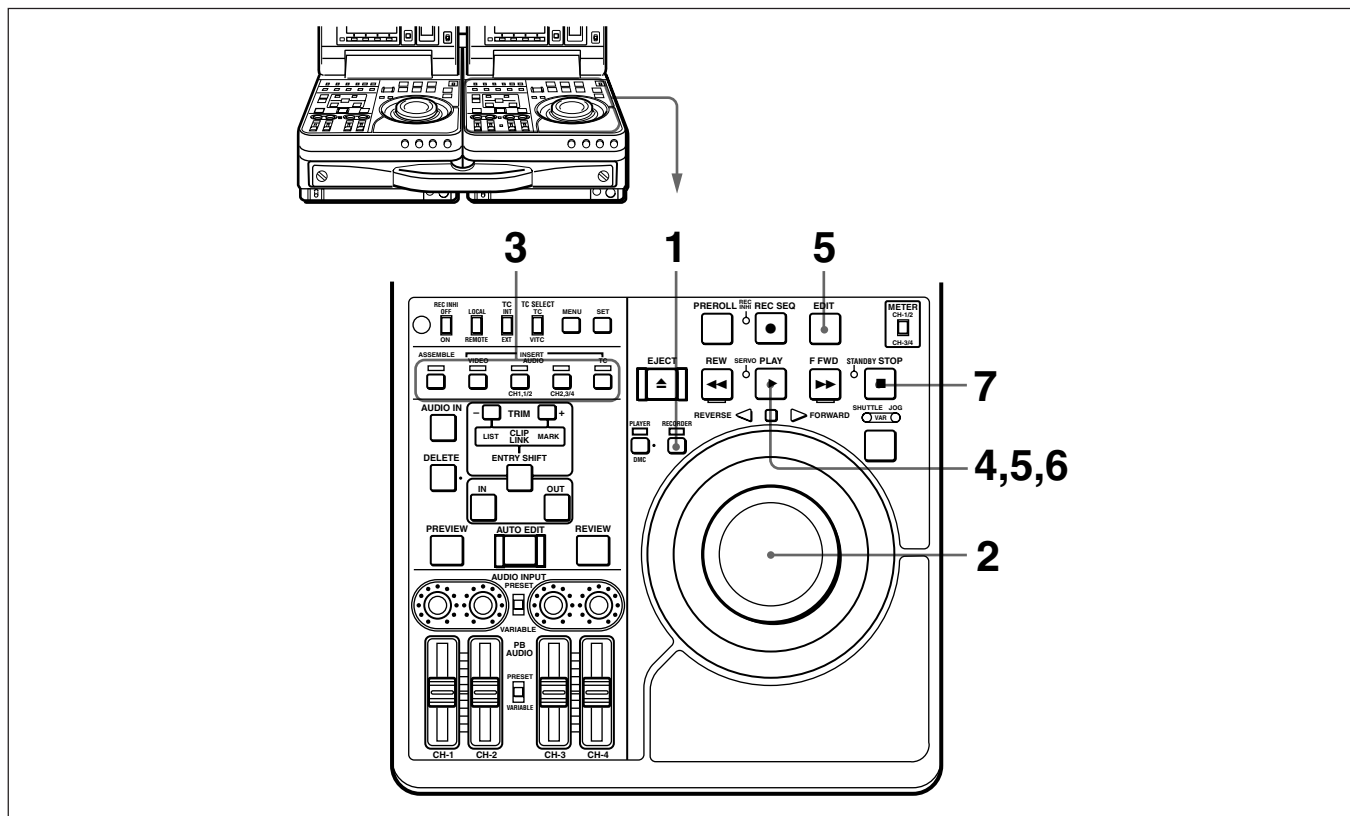

1 Press the RECORDER button, lighting the indicator.

2 Use the jog or shuttle dial to find the point where the edit will start (the recorder IN point), and stop the tape slightly in advance of this point.

3 Select the edit mode.

4 Press the PLAY button.

Recorder playback starts.

Note

About 2 seconds are required for the picture to stabilize. You should begin playback at a point on the tape more than 2 seconds in advance of the section you will use in the edit.

5 Press the EDIT button together with the PLAY button at the point where you want to start the edit (the recorder IN point).

The edit starts.

6 Press the PLAY button at the point where you want to end the edit (the recorder OUT point).

The edit ends but recorder playback continues.

7 Press the STOP button to stop recorder playback.

ClipLink Operation

Overview of ClipLink Operation

The ClipLink function provides the following.

- Displaying ClipLink log data
- Cueing up to Mark IN/OUT points and cue points
- Rewriting ClipLink log data (reel numbers, Mark IN/OUT points, and OK/NG status only)
- Creating additional ClipLink log data and deleting ClipLink log data (Mark IN/OUT points only)
- Automatically creating new ClipLink log data (Mark IN/OUT points only)

When Mark IN/OUT points are created, the scene number and take number for them are fixed at 000 and 00, respectively.

The above operations other than automatic creation of new ClipLink log data require the ClipLink log data list display.

Notes

- For a tape on which index pictures are already recorded, you cannot change any ClipLink log data other than the reel numbers and OK/NG status. (When index pictures are recorded on a tape, the ClipLink log data list for the tape shows an IP indication.)
- You cannot carry out ClipLink operation such as “Continue” on the DSR-1/IP or DSR-300/300P for a tape whose ClipLink log data has been modified on this unit.

For an overview of the ClipLink function, see the appendix “ClipLink Guide” (page 147).

Displaying ClipLink Log Data

To display ClipLink log data, hold down the ENTRY/SHIFT button and press the TRIM-/LIST button.

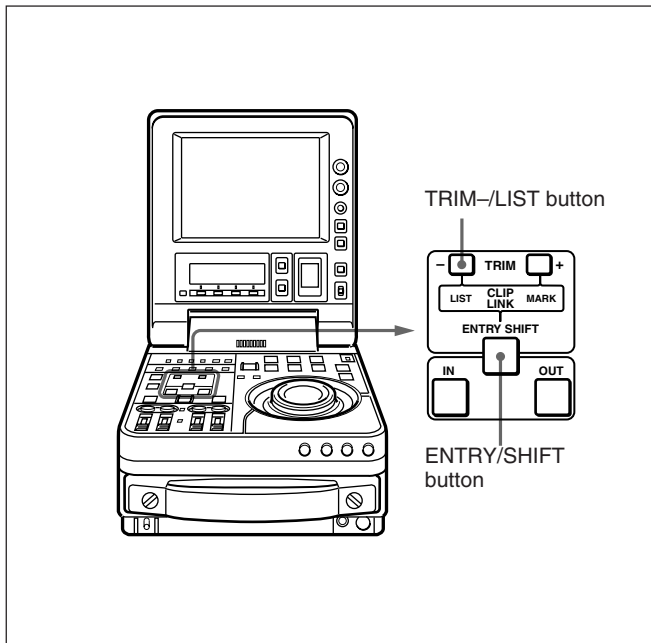

The following ClipLink log data list appears in the monitor.

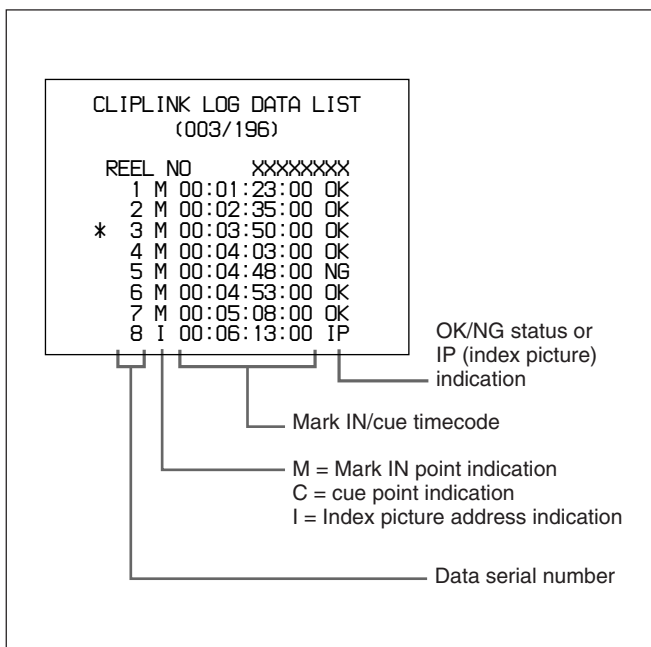

To return to the original monitor display

To exit from the ClipLink log data list and return to the original monitor display, hold down the ENTRY/SHIFT button and press the TRIM-/LIST button.

Detailed Data Display

To check more details related to the data item selected on the ClipLink log data list, proceed as follows.

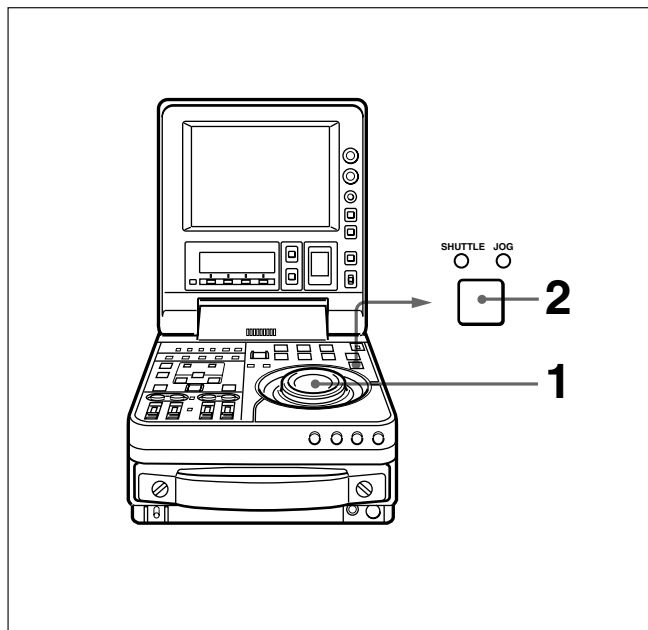

1 Using the shuttle/jog dial, move the selection mark (asterisk) to the data item for which you wish to display details.

2 Press the search button.

While you hold the search button down, the detailed data display appears.

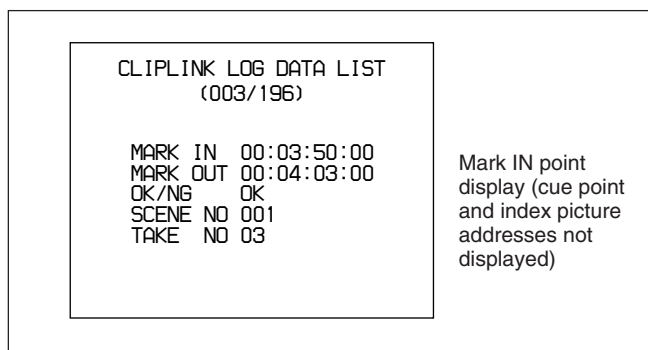

Cuing Up to Mark IN/OUT and Cue Points

Cuing Up to Any Desired Position

To cue up to the point specified by the data item selected on the ClipLink log data list, proceed as follows.

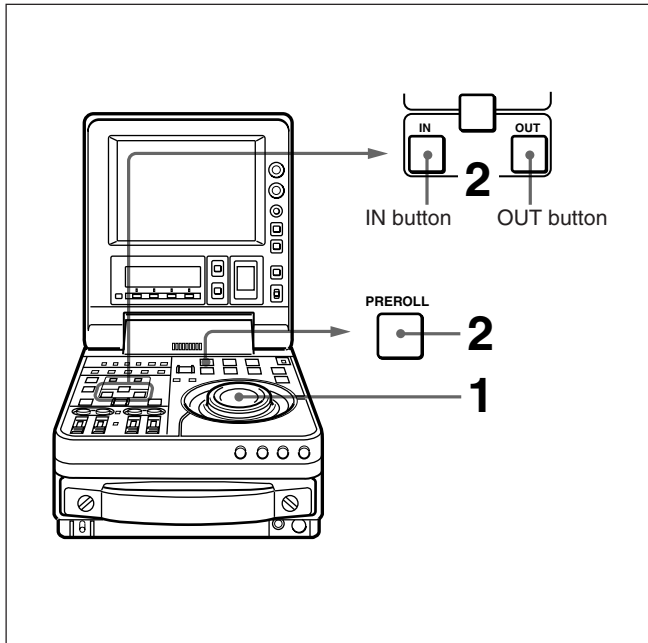

- 1 Using the jog/shuttle dial, move the selection mark (asterisk) to the desired data item on the ClipLink log data list.

When the selected data item display contains “M” mark

The Mark IN point address is stored as the IN point and the Mark OUT point address is stored as the OUT point. At the same time, the IN button and the OUT button on the control panel light.

When the selected data item display contains “C” mark

The cue point address is stored as the IN point and the IN button on the control panel lights.

- 2 Operate as follows.
 - **To cue up to the mark IN point or cue point**
Holding down the IN button, press the PREROLL button.
 - **To cue up to the mark OUT point**
Holding down the OUT button, press the PREROLL button.

This exits from the ClipLink log data list and cues up to the selected position.

Cuing Up to Adjacent Mark IN/ Cue Points

Once you select data on a ClipLink log data list, you can cue up to the point preceding or following the selected data with ease without reverting to the ClipLink log data list.

To cue up to the Mark IN point or cue point preceding the current point selected on the list

Holding down the TRIM+/MARK button, press the REW button.

During the cue-up operation is in progress, the REW button flashes.

To cue up to the Mark IN point or cue point following the current point selected on the list

Holding down the TRIM+/MARK button, press the F FWD button.

During the cue-up operation is in progress, the F FWD button flashes.

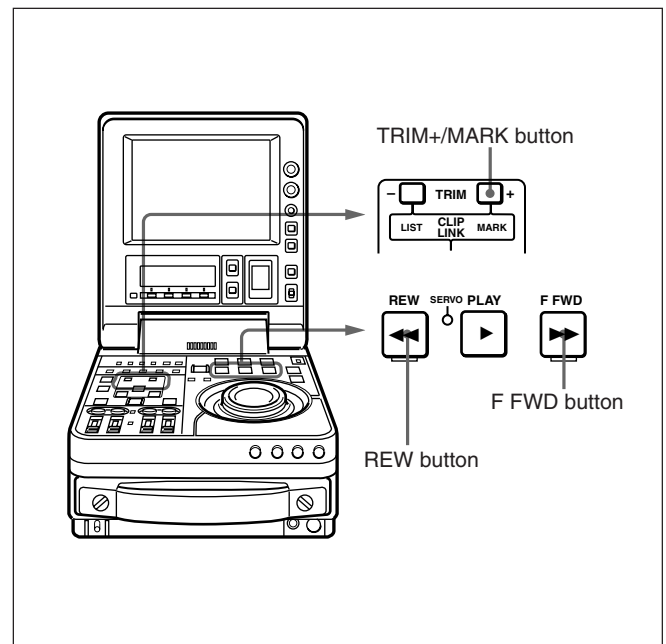

Rewriting ClipLink Log Data

You can rewrite the reel number, Mark IN/OUT points and OK/NG status included in the ClipLink log data.

Changing the Reel Number

To change the reel number of the data item selected on the ClipLink log data list, proceed as follows.

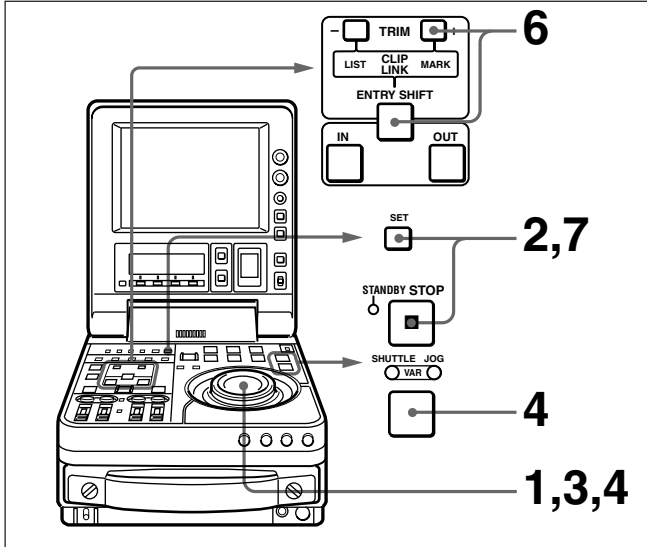

1 Using the jog/shuttle dial, move the selection mark (asterisk) to the desired data item on the ClipLink log data list.

2 Hold down the STOP button and press the SET button.

The following setting screen appears.

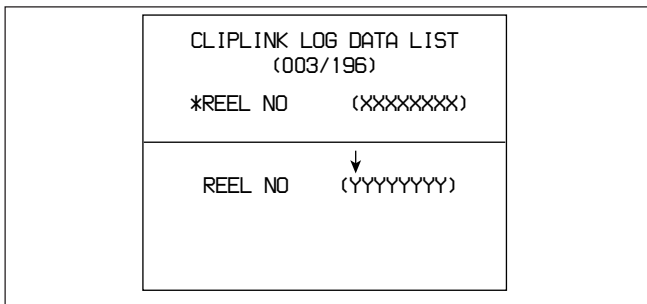

3 Turn the jog/shuttle dial to select the digit to change.

Rotating the jog/shuttle dial clockwise moves the current digit position to the right, and counterclockwise moves it to the left.

4 Hold down the search button and turn the jog/shuttle dial to change the digit indicated by an arrow (↓).

5 Repeat steps **3** and **4** until the settings for all digits are complete.

6 When all digits have been set, hold down the ENTRY/SHIFT button and press the TRIM+/MARK button.

The reel number changes.

7 Hold down the STOP button and press the SET button.

This returns to the original ClipLink log data list.

Note

If you carry out step **7** skipping step **6**, the original ClipLink log data list appears again on the monitor and, in this case, the reel number is not rewritten.

Changing Mark IN/OUT Points

To change Mark IN/OUT points selected on the ClipLink log data list, perform the following procedure.

When Mark IN/OUT points are rewritten to the cassette memory, the frame digits of the address data are processed as follows.

For Mark IN point: Any frame-digits value is counted as 1 second.

For Mark OUT point: Any frame-digits value is ignored.

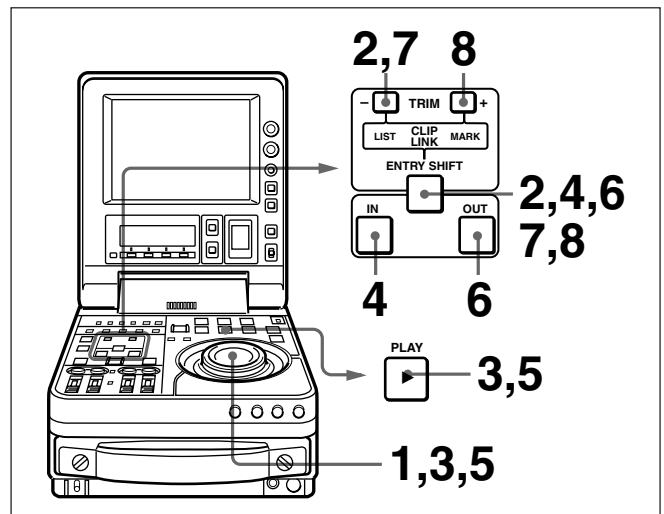

- Using the jog/shuttle dial, move the selection mark (asterisk) to the desired data item on the ClipLink log data list.

The Mark IN point address is stored as the IN point and the Mark OUT point address is stored as the OUT point. At the same time, IN button and the OUT button light.

- Perform either one of the following operations.
 - Hold down the ENTRY/SHIFT button and press the TRIM-/LIST button, exiting from the ClipLink log data list.
 - Cue up to the IN point or OUT point. (See page 95.)
- Cue up to the tape position to be made the new Mark IN point. (See “Finding Edit Points — Search” (page 79).)
- Holding down the IN button, press the ENTRY/SHIFT button.

The ENTRY/SHIFT button lights and the Mark IN point address changes.

- Cue up to the tape position to be made the new Mark OUT point. (See “Finding Edit Points — Search” (page 79).)
- Holding down the OUT button, press the ENTRY/SHIFT button.

The Mark OUT point address changes.

- Holding down the ENTRY/SHIFT button, press the TRIM-/LIST button to display the ClipLink log data list, then make sure the selection mark (asterisk) is kept at the position of the desired data item selected in step 1.

If the selection mark (asterisk) is at a wrong position

Using the jog/shuttle dial, return the selection mark to the desired data item.

- Holding down the ENTRY/SHIFT button, press the TRIM+/MARK button.

The ENTRY/SHIFT button goes out and the Mark IN point and Mark OUT point addresses are rewritten.

Changing the OK/NG Status

To change the OK/NG status of the data item selected on the ClipLink log data list, proceed as follows.

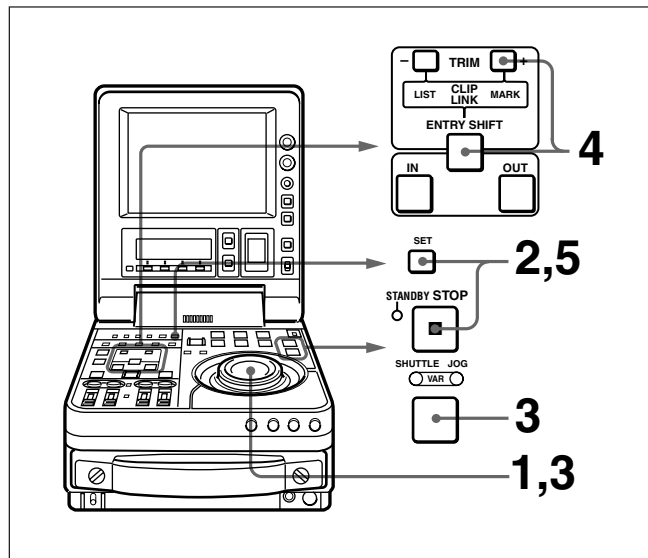

- Using the jog/shuttle dial, move the selection mark (asterisk) to the desired data item on the ClipLink log data list.
- Hold down the STOP button and press the SET button.

The following setting screen appears.

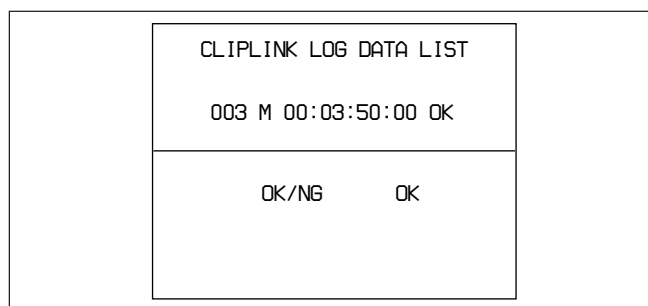

- Hold down the search button and turn the jog/shuttle dial to change the setting to OK or NG as required.
- Holding down the ENTRY/SHIFT button, press the TRIM+/MARK button.

The OK/NG status is rewritten.

(Continued)

Rewriting ClipLink Log Data

- 5** Hold down the STOP button and press the SET button.

This returns to the original ClipLink log data list.

Note

If you carry out step **5** skipping step **4**, the original ClipLink log data list appears again on the monitor and, in this case, the OK/NG status is not rewritten.

Adding to/Deleting From ClipLink Log Data

You can add new Mark IN/OUT point data to the ClipLink log data or delete Mark IN/OUT point data from the ClipLink log data.

Adding Mark IN/OUT Points

Set the setup menu item 129 (CLIPLINK) to ON beforehand, then proceed as follows.

For information about how to operate the setup menu, see Chapter 7 “Setup Menu” (page 103).

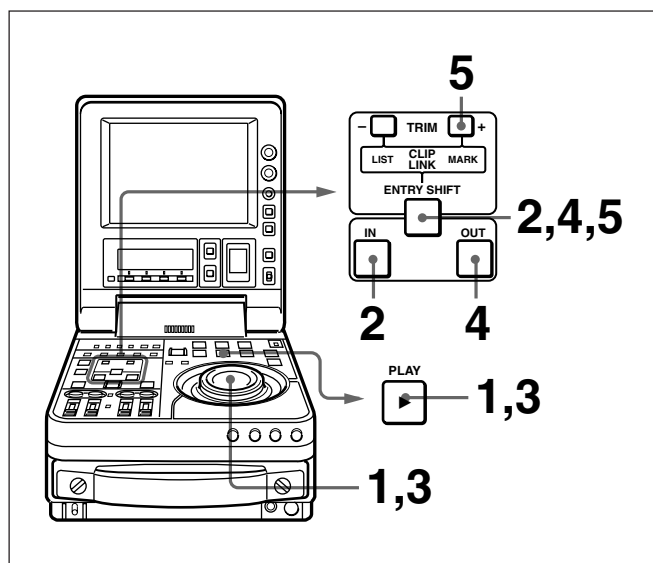

- 1** Cue up to the tape position you wish to make an additional Mark IN point. (See “Finding Edit Points— Search” (page 79).)
- 2** Holding down the IN button, press the ENTRY/SHIFT button.

The IN button and ENTRY/SHIFT button light, and the Mark IN point address is set.
- 3** Cue up to the tape position you wish to make an additional Mark OUT point. (See “Finding Edit Points— Search” (page 79).)
- 4** Holding down the OUT button, press the ENTRY/SHIFT button.

The OUT button lights, and the Mark OUT point address is set.

- 5** Holding down the ENTRY/SHIFT button, press the TRIM+/MARK button.

The ENTRY/SHIFT button goes out, and the Mark IN point and Mark OUT point data is added to the end of the existing ClipLink log data.

Note

The volume of ClipLink log data that can be stored in a cassette memory depends on the cassette memory capacity as follows.

Cassette memory capacity	Storable volume of data
4K bits	45 pairs of Mark IN and Mark OUT points
16K bits	198 pairs of Mark IN and Mark OUT points

When adding to the existing ClipLink log data, carefully watch the ClipLink log data list not to allow the additional data to exceed the available cassette memory capacity.

Deleting Mark IN/OUT Points

After displaying the ClipLink log data, proceed as follows.

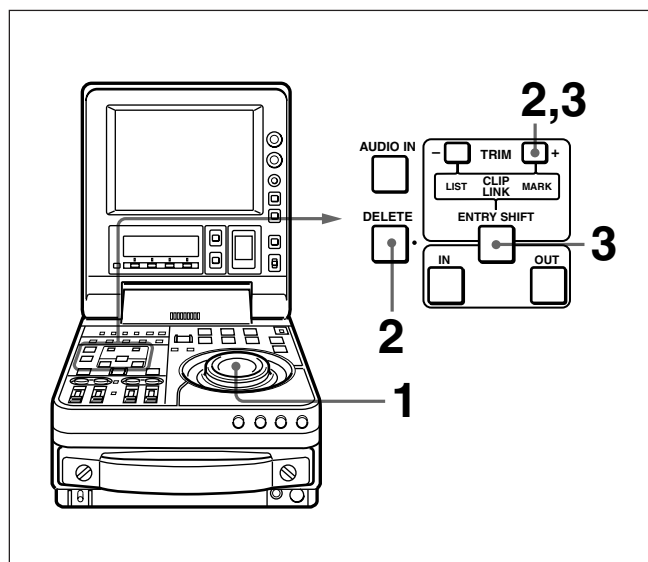

- 1** Using the jog/shuttle dialog, move the selection mark (asterisk) to the desired data item on the ClipLink log data list.

(Continued)

Adding to/Deleting From ClipLink Log Data

- 2** Holding down the DELETE button, press the TRIM+/MARK button.

The specified data disappears from the ClipLink log data list.

- 3** Holding down the ENTRY/SHIFT button, press the TRIM+/MARK button.

Note

If you exit from the ClipLink log data list skipping step **3**, the previous data is restored. The data specified for deletion is not deleted.

Automatically Creating New ClipLink Log Data

When the setup menu item 129 (CLIPLINK) is set to ON, you can automatically create new Mark IN/OUT points during recording or editing operation.

For information about how to operate the setup menu, see Chapter 7 “Setup Menu” (page 103).

New Mark IN/OUT points are created as follows.

Operation	Automatic creation of Mark IN/OUT points
Recording	The recording starting point is made a Mark IN point and the recording ending point is made a Mark OUT point.
Editing	The edit IN point (the video IN point or audio IN point whichever coming first) is made a Mark IN point and the edit OUT point is made a Mark OUT point.

Notes

- If recording or editing is carried out when the setup menu item 129 (CLIPLINK) is set to OFF, the existing ClipLink log data is erased.
- If you carry out recording or editing on a tape on which index pictures are already recorded, the existing ClipLink log data for the tape is lost.
- The Mark IN/OUT point data automatically created during recording or editing operation for a tape on which no index pictures are recorded is added to the end of the existing ClipLink log data for the tape.
- If you carry out recording or editing on a tape position linked to the existing ClipLink log data, the link between them is lost. Therefore, when you start creating new ClipLink log data, where on the tape to start recording or editing must be determined very carefully. If the existing ClipLink log data is no longer required, erase it beforehand.

To erase ClipLink log data

After displaying the ClipLink log data list, proceed as follows.

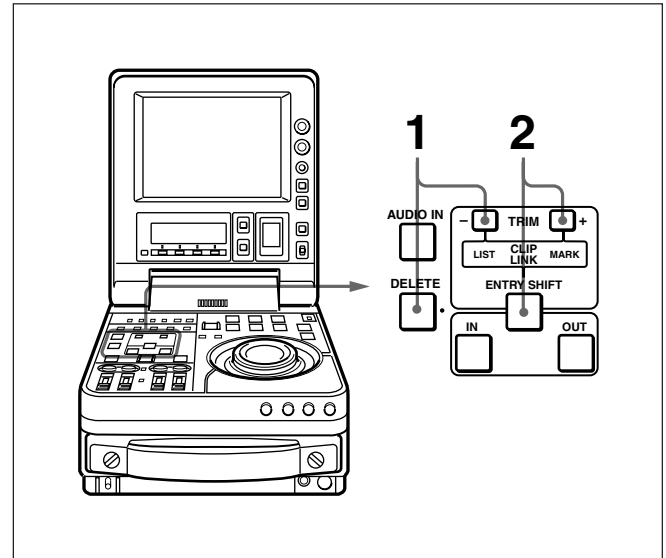

- 1** Holding down the DELETE button, press the TRIM-/LIST button.

The data shown on the ClipLink log data list disappears.

- 2** Holding down the ENTRY/SHIFT button, press the TRIM+/MARK button.

The message “NO CLIPLINK LOG DATA” appears on the screen and the ClipLink log data is completely erased.

Setup Menu

Menu System Configuration

The menu system of this unit comprises the basic menu and extended menu.

- **Basic menu**

This menu is used to make settings relating, for example, to the following.

- the digital hours meter
- the preroll time
- the character information superimposed on the output to the monitor

For detailed information about menu operation relating to the digital hours meter, see “Digital hours meter” (page 136).

- **Extended menu**

This menu is used to make a wide range of settings relating to the functions of this unit, for example, the control panel functions, video and audio control, and digital data processing.

Basic Menu

Items in the Basic Menu

The basic menu items (excluding the items related to the digital hours meter) are listed in the following table.

In the “Settings” column of the table, the factory default settings are underlined.

Basic Menu

Items in the basic menu

Item number	Item name	Settings
001	PREROLL TIME	0S... 5S ...30S: Set the preroll time to between 0 and 30 seconds in steps of 1 second. A preroll time of at least 5 seconds is recommended when using this unit for editing.
002 ^{a)}	CHARACTER H-POSITION	Adjust the horizontal screen position of the character information (as a hexadecimal value) which is superimposed on output from the VIDEO OUTPUT 2 (SUPER) connector and display on the LCD monitor. 00... 08 ...10 (DSR-70A)/00... 09 ...12 (DSR-70AP): The hexadecimal value 00 is for the far left of the screen. Increasing the value moves the position of the characters to the right.
003 ^{a)}	CHARACTER V-POSITION	Adjust the vertical screen position of the first line of the character information (as a hexadecimal value) which is superimposed on output from the VIDEO OUTPUT 2 (SUPER) connector and display on the LCD monitor. 00... 15 ...1A (DSR-70A)/00... 1A ...1E (DSR-70AP): The hexadecimal value 00 is for the top of the screen. Increasing the value lowers the position of the characters.
004	SYNCHRONIZE	When editing using this unit as a controller and an external VTR connected to this unit via a 9-pin remote control cable or i. LINK/DV cable, this item determines whether or not to operate the two units in phase synchronization. ON: Operate in phase synchronization. OFF: Do not operate in phase synchronization.
005	DISPLAY INFORMATION SELECT	Determine the kind of character information which is superimposed on output from the VIDEO OUTPUT 2 (SUPER) connector and display on the LCD monitor when the sub LCD menu item CHARACTER is set to ON. T&STA: Time data and the units status. T&UB: Time data and user bit data. (When UB is selected with the COUNTER SELECT button, the user bit data and time data arranged in that order are displayed.) T&CNT: Time data and counter count. (When CNT is selected with the COUNTER SELECT button, the counter count and time data arranged in that order are displayed.) T&T: Time data and timecode (TC or VITC) TIME: Timecode (LTC or VITC) only. DATE: Recording date and time.
006	LOCAL FUNCTION ENABLE	Determine which tape transport control buttons on the control panel are enabled when this unit is controlled from external equipment. DIS: All buttons and switches are disabled. ST&EJ: Only the STOP button and EJECT button are enabled. ENA: All buttons and switches except the RECORDER button and PLAYER/DMC button are enabled.
007	TAPE TIMER DISPLAY	Determine whether to display the counter in 12-hour mode or 24-hour mode. + -12H: 12-hour mode 24H: 24-hour mode
008	MONITORING SELECTION FOR VTR-TO-VTR EDIT	For editing with two DSR-70A/70AP units, determine whether the recorder unit is forced into E-E mode when the recorder PLAYER/DMC button is pressed to view the player playback signals on the LCD monitor on the recorder. MANU: Do not force the recorder into E-E mode. AUTO: Force the recorder into E-E mode.
009 ^{a)}	CHARACTER TYPE	Determine the type of character information (timecode, etc.) which is superimposed on output from the VIDEO OUTPUT 2 (SUPER) connector and displayed on the LCD monitor. WHITE: White letters on a black background. BLACK: Black letters on a white background. W/OUT: White letters with black outline. B/OUT: Black letters with white outline.

a) When setting items 002, 003, and 009, watch the monitor screen, and adjust to the required state.

(Continued)

Items in the basic menu (continued)

Item number	Item name	Settings
011 ^{a)}	CHARACTER V-SIZE	Determine the vertical size of character information (timecode, etc.) which is superimposed on output from the VIDEO OUTPUT 2 (SUPER) connector and displayed on the LCD monitor. ×1: Standard size ×2: 2 times standard size
014	SEQUENTIAL RECORD MODE	Select the mode for two-unit sequential recording. OFF: No sequential recording. MANUAL CASSETTE REPLACE: Do sequential recording one time. Exchange the cassettes when one sequential recording finishes. AUTOMATIC OVERWRITE: Do sequential recording, overlaying previously recorded contents. (Do not exchange cassettes.)
015 ^{a)}	MENU DISPLAY	Determine the type of characters in menu text superimposed on output from the VIDEO OUTPUT 2 (SUPER) connector and displayed on the LCD monitor. WHITE: White letters on a black background. BLACK: Black letters on a white background. W/OUT: White letters with black outline. B/OUT: Black letters with white outline.
016	ALARM	Select whether or not to display alarm messages. OFF: No alarm messages. LIMIT: Display alarm messages only during recording or editing. ON: Display alarm messages.
099	MENU GRADE	For setup menu operations, select whether to superimpose on output from the VIDEO OUTPUT 2 (SUPER) connector and display on the LCD monitor the basic menu information only or both the basic menu information and the extended menu information. BASIC: Display the basic menu information only. ENHAN: Display both the basic menu information and the extended menu information.

a) When setting items 011 and 015, watch the monitor screen, and adjust to the required state.

Item number	Item name	Settings
B01	RECALL BANK 1	Set to ON to recall menu settings from menu bank 1.
B02	RECALL BANK 2	Set to ON to recall menu settings from menu bank 2.
B03	RECALL BANK 3	Set to ON to recall menu settings from menu bank 3.
B04	RECALL BANK 4	Set to ON to recall menu settings from menu bank 4.
B11	SAVE BANK 1	Set to ON to save current menu settings to menu bank 1.
B12	SAVE BANK 2	Set to ON to save current menu settings to menu bank 2.
B13	SAVE BANK 3	Set to ON to save current menu settings to menu bank 3.
B14	SAVE BANK 4	Set to ON to save current menu settings to menu bank 4.

Basic Menu

Basic Menu Operations

This section describes the basic menu displays and how to change the settings.

Displaying the menus

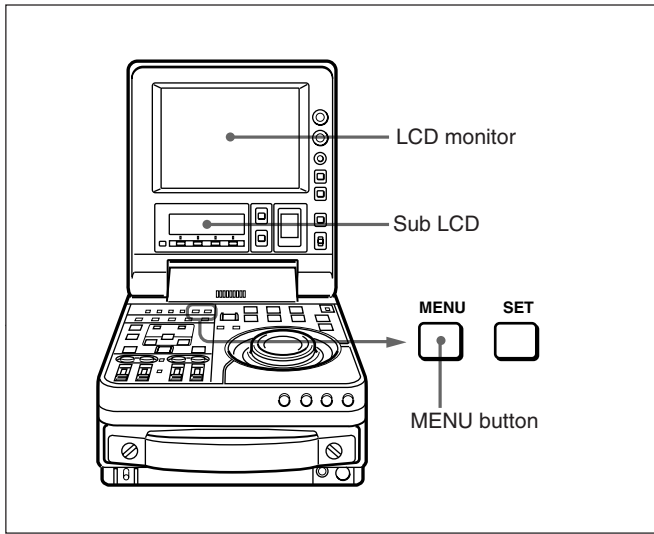

Press the MENU button.
The setting of the currently selected menu item appears in the LCD monitor and sub LCD.

Output from the VIDEO OUTPUT 2 (SUPER) connector

When the sub LCD menu item CHARACTER is set to ON, the same menu screen also appears on a monitor connected to the VIDEO OUTPUT 2 (SUPER) connector as shown in the LCD monitor.

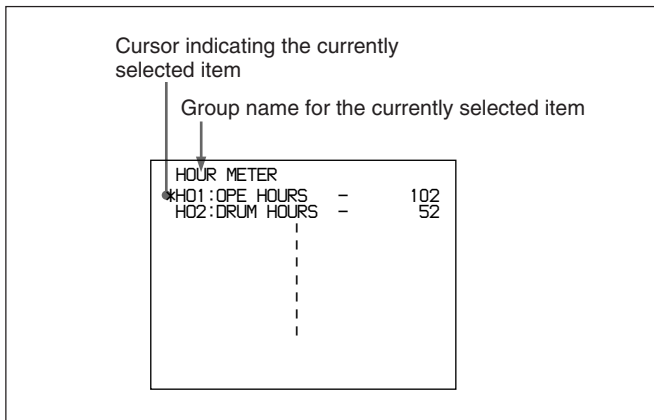

Changing the currently displayed menu item

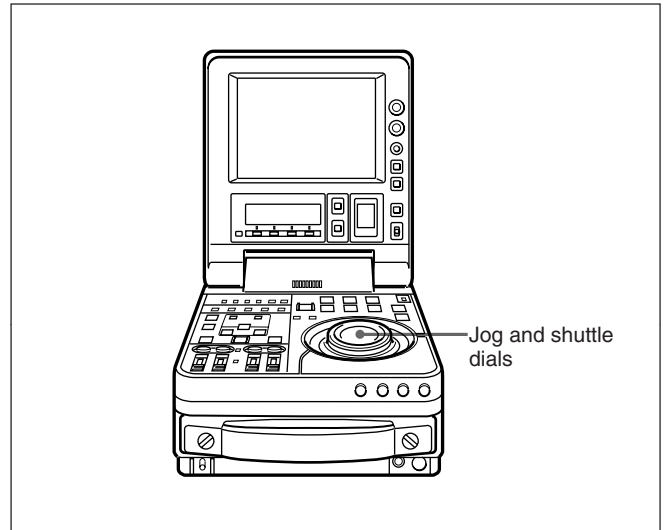

Turn the jog or shuttle dial depending on the current search mode (indicated by JOG/SHUTTLE indicators). Turning the jog or shuttle dial in the clockwise direction increments the item number, and turning it in the counterclockwise direction decrements the item number.
If you turn the shuttle dial, the item number changes at a rate depending on the shuttle dial angle. If you turn the jog dial, the item number changes on the jog dial rotation speed.

Changing a menu item setting value

To change the setting value of the currently displayed menu item use the following procedure.

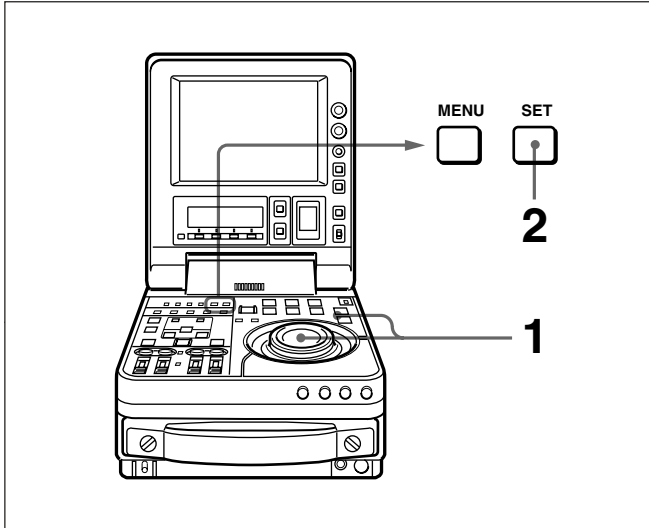

- 1** Holding down the search button, turn the jog or shuttle dial.

The setting value changes at a rate depending on the shuttle dial angle or on the jog dial rotation speed.

- 2** When the desired setting value is displayed, press the SET button.

This saves the new setting value, and the menu display disappears.

To abandon making a change

Press the MENU button before pressing the SET button.

The menu display disappears from the LCD monitor and sub LCD, without the new setting value being saved.

Resetting the menu settings to their factory default values

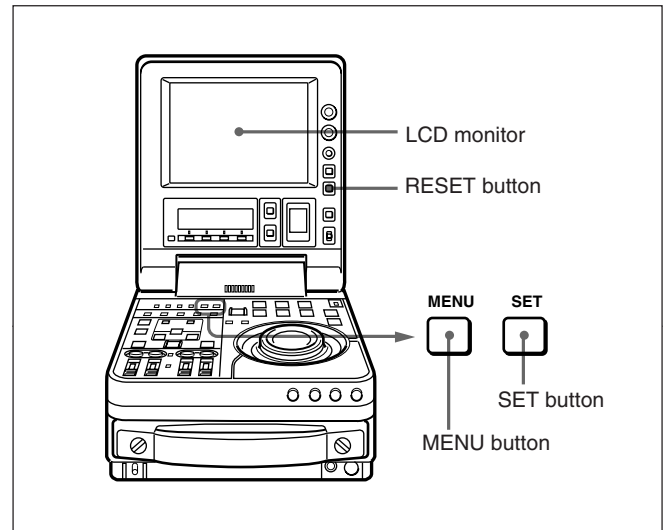

- 1** Set the MENU button.

The menu appears on the LCD monitor.

- 2** Press the RESET button.

- 3** Press the SET button.

The menu settings are reset to their factory default settings.

Basic Menu

Menu bank operations (menu items B01 to B14)

This unit allows four different complete sets of menu settings to be saved in what are termed “menu banks” numbered 1 to 4. Saved sets of menu settings can be recalled for use as required.

To jump to menu item B01

You can recall any required menu by turning the search dial after pressing the MENU button. If you press the MENU button first, then the COUNTER SEL button, you can jump directly to menu item B01 or H01. The recalled menu item toggles between B01 and H01 every time you press the COUNTER SEL button.

Saving the current active menu settings

Set one of menu items B11 SAVE BANK 1 to B14 SAVE BANK 4 to ON, depending on which of the menu banks you wish to save in, then press the SET button.

Recalling settings from a menu bank

Set one of menu items B01 RECALL BANK 1 to B04 RECALL BANK 4 to ON, depending on which of the menu banks you wish to recall from, then press the SET button.

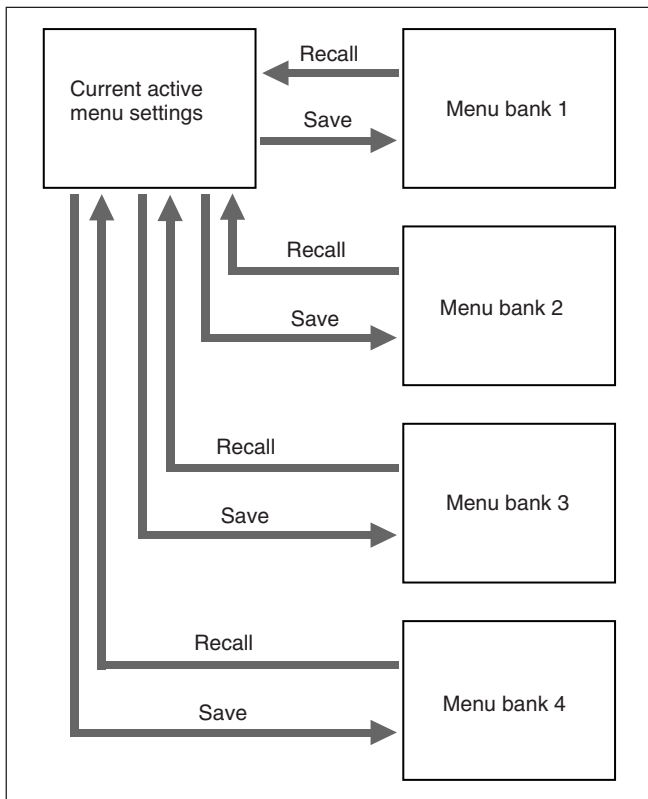

Extended Menu

Items in the Extended Menu

The extended menu contains the following items.
In the Settings column of the table, the factory default settings are underlined.

Menu items in the 100s, relating to the control panels

Item number	Item name	Settings
101	SELECTION FOR SEARCH DIAL ENABLE	Select how the unit enters the search mode. DIAL: Turning the jog or shuttle dial switches to search mode at all times except during recording/editing. KEY: The search button must be pressed to switch to search mode.
102	MAXIMUM TAPE SPEED	Specify the maximum tape speed in REW (rewind) mode.
	Sub-item	
	1 SHUTTLE	Specify the maximum tape speed in search mode (shuttle). X16: Maximum 16 times normal X32 : Maximum 32 times normal X60: Maximum 60 times normal
2	F.FWD/REW	Specify the maximum tape speed in F.FWD/REW mode. X32: Maximum 32 times normal X60: Maximum 60 times normal X85 : Maximum 85 times normal MAX: No maximum tape speed is specified. Note When this item is set to MAX, the playback video signal is muted.
105	REFERENCE SYSTEM ALARM	Select whether or not to display alarm messages concerning the reference video signal. ON: Flash the STOP button and display an alarm message. LIMIT: Flash the STOP button and display an alarm message only either when the unit is in recording mode or E-E mode or when editing operation is being carried out. OFF: No alarm messages.
107	REC INHIBIT LAMP FLASHING	Select whether or not to flash the REC INHI indicator when recording is prevented though the REC INHI switch on the control panel is set to OFF. OFF: Light the REC INHI indicator. ON: Flash the REC INHI indicator.
108	AUTO EE SELECT	When a cassette is inserted and the PB/EE item in the sub LCD menu general settings page is set to PB/EE, select the operation modes in which input video and audio signals are automatically handled in E-E mode. S/F/R: In STOP/F FWD (fast-forward)/REW (rewind) modes STOP: In STOP mode
109	FORCED EE WHEN TAPE UNTHREAD	During tape threading and unthreading, and when no cassette is inserted, select whether the PB/EE item of the sub LCD menu general settings page controls the output signal PB/EE setting. ON: No control (the signal is always an E-E signal). OFF: Control.

(Continued)

Extended Menu

Menu items in the 100s, relating to the control panels (continued)

Item number	Item name	Settings	
118	KEY INHIBIT SWITCH EFFECTIVE AREA	Select which switches and buttons can be operated when the KEY INH in the sub LCD menu is set to ON. The following sub-items control different sets of switches and buttons independently.	
	Sub-item		
	1	REMOTE SELECT	Select whether the REMOTE/LOCAL switch on the control panel is enabled. DIS: Disabled. ENA: Enabled.
	2	CONTROL PANEL	Select which switches and buttons operations on the control panel are enabled. DIS: All switches and buttons are disabled. EDIT: All switches and buttons for editing operations are disabled. ENA: All switches and buttons are enabled.
119	VARIABLE SPEED LIMIT IN KEY PANEL CONTROL	Select the playback speed range when carrying out playback in variable speed mode from the control panel of this unit. OFF: -1 to +2 times normal speed ON: $-1/2$ to $+1/2$ times normal speed.	
125	AUTO REWIND	Select whether to rewind the tape automatically when recording or playback reaches the end of a tape. DIS: Do not rewind the tape automatically. ENA: Rewind the tape automatically.	
128	PAUSE FUNCTION	Select whether to use the search button as a pause button. OFF: Do not use as a pause button. ON: Use as a pause button.	
129	CLIPLINK	Select whether to create ClipLink log data. OFF: Do not create. ON: Create. When recording, the recording starting point is made a Mark IN point and the recording ending point is made a Mark OUT point. When editing, the edit IN point (the video IN point or audio IN point whichever coming first) is made a Mark IN point and the edit OUT point is made a Mark OUT point. Note If recording or editing is carried out when this item is set to OFF, the existing ClipLink log data is erased.	

Menu items in the 200s, relating to the remote control interface

Item number	Item name	Settings
201	PARA RUN	Select whether or not to use synchronized operation for two or more VTRs. DIS: No synchronized operation. ENA: Use synchronized operation. Note To use synchronized operation for two or more VTRs, set item 201 to ENA on all of the VTRs.

Menu items in the 300s, relating to editing operations

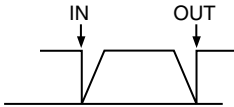
Item number	Item name	Settings
301	VAR SPEED RANGE FOR SYNCHRONIZATION	Select the playback speed range when carrying out playback in variable speed mode from a remote control unit connected to the REMOTE-IN connector or REMOTE-OUT connector. -0.5 ~ 0.5: -0.5 to +0.5 times normal speed. -1 ~ +2 : -1 to +2 times normal speed
305	SYNC GRADE	When editing in phase-synchronized mode with item 004 set to ON, select the target phase synchronization accuracy. ACCUR: ±0 frame accuracy. ROUGH: ±1 frame accuracy.
306	DMC INITIAL SPEED	Select the initial speed automatically set when carrying out DMC editing. MANU : The speed determined by the rotation of the search dial. PLAY: Normal playback speed. STILL: Stationary. ±0.03 ~ ±1: Speed set in the range ±0.03 to ±1 (select from ±1, ±0.5, ±0.03, ±0.2, ±0.1.)
307	AUTO-DELETION FOR INCONSISTENT DATA	Select what happens when an erroneous edit point is set. MANU: A warning is given by flashing the DELETE button on the control panel. The operator must manually delete the unnecessary edit point . NEG&E: When inconsistent edit points are set, such as when an OUT point is before an IN (or audio IN) point, or when too many edit points are specified, the previously set edit point is deleted. NEG: When inconsistent edit points are set, such as when an OUT point is before an IN (or audio IN) point, the previously set edit point is deleted. When too many edit points are specified, the DELETE button on the control panel flashes to give a warning. Note Pressing the button corresponding to an edit point to be deleted and the DELETE button simultaneously deletes the edit point. If an erroneous edit point is set (the DELETE button is flashing), editing is not executed.
308	SELECTION OF STD/NON-STD FOR ANALOG VIDEO IN	Select the STD or NON-STD mode in accordance with a composite video or S-video input. STD: The STD mode is always used (forced STD mode). N-STD: Use this setting when the input video signal is unstable (forced NON-STD mode). When using a VCR with no built-in time base corrector (e.g. a home-use VHS-system VCR), select N-STD.
317	AUDIO EDIT MODE	Specify the type of editing for audio signals. CUT: Cut editing (discontinuity in audio signal may result at the editing point, causing noise.) FADE: Fade out and fade in 
318	EDIT RETRY	When editing with two DSR-70A/70AP units, set for the recorder. Selects the operation if the recorder was not synchronized in time. OFF: Editing is not carried out, and the unit stops. ON: The editing is automatically retried (up to twice).

(Continued)

Extended Menu

Menu items in the 300s, relating to editing operations (continued)

Item number	Item name	Settings
326	AUTOMATIC IN ENTRY AFTER AUTO EDIT	Select whether or not to automatically set the OUT point of the previous edit as the next IN point at the end of an automatic edit. OFF : No automatic setting. R : Set recorder IN point automatically. R & P : Set recorder IN point automatically, and also player IN point in two-VCR editing.
327	AUDIO MODE CHANGE	Select whether to allow audio data recorded on tape in two-channel mode (or four-channel) to be re-recorded in four-channel (or two-channel mode). OFF : Do not allow re-recording in a different audio mode. ON : Allow re-recording in a different audio mode.
335	OUTPUT REFERENCE SEL	Select the reference video signal to use. REF : Use the signal input to the REF. VIDEO IN connector as the reference video signal. The input video signal to be edited is required to be in synchronization with the reference video signal. VIDEO : Use the input video signal as the reference video signal.

Menu items in the 400s, relating to preroll

Item number	Item name	Settings
401	FUNCTION MODE AFTER CUE-UP	Select the state that the unit goes into after a cuing-up operation. STOP : Stops (the STOP mode). STILL : Still playback (in search mode).
403	AUTOMATIC PREROLL REFERENCE ENTRY	Select whether or not the edit IN point is automatically set by pressing the PREROLL button when the IN point is not set before starting preroll. DIS : IN point is not set automatically. ENA : IN point is set automatically.

Menu items in the 500s, relating to tape protection

Item number	Item name	Settings
501	STILL TIMER	Select the time delay from the tape transport stopping (either the "STOP" mode or the still playback mode in search mode) until the unit automatically switches to the tape protection mode, in order to protect the rotary heads and the tape. 0.5S... 1M ...5M : Set the value in the range 0.5 seconds to 5 minutes.
502	TAPE PROTECTION MODE FROM SEARCH	Select the type of tape protection to use when switching from still playback in search (jog/shuttle) mode to tape protection mode. STEP : Step forward at 0.03 times normal speed for 2 seconds. STDBY : Switch to Standby OFF mode (the unit not on standby).

Menu items in the 600s, relating to the time code generator

Item number	Item name	Settings
601	VITC POSITION SEL-1	<p>Select a line to insert the VITC in.</p> <p>12H ... 16H ... 20H: Select any line from 12 to 20. (DSR-70A)</p> <p>9H ... 19H ... 22H: Select any line from 9 to 22. (DSR-70AP)</p> <p>Note</p> <p>You can insert the VITC signal in two places. To insert it in two places, set both items 601 and 602.</p>
602	VITC POSITION SEL-2	<p>Select a line to insert the VITC in.</p> <p>12H ... 18H ... 20H: Select any line from 12 to 20. (DSR-70A)</p> <p>9H ... 21H ... 22H: Select any line from 9 to 22. (DSR-70AP)</p> <p>Note</p> <p>You can insert the VITC signal in two places. To insert it in two places, set both items 601 and 602.</p>
605	TCG REGEN MODE	<p>Select the signal to be regenerated when the time code generator is in the regeneration mode (i.e., when the PRESET/REGEN item in the sub LCD menu general settings page is set to REGEN, or the unit is in automatic edit mode).</p> <p>TC&UB: Both the timecode and user bits are regenerated.</p> <p>TC: Only the timecode is regenerated.</p> <p>UB: Only the user bits are regenerated.</p>
607	U-BIT BINARY GROUP FLAG	<p>Select the user bits to be used in the time code generated by the time code generator.</p> <p>000: Character set not specified.</p> <p>001: 8-bit characters compliant with ISO 646 and ISO 2022.</p> <p>010: Undefined.</p> <p>011: Undefined.</p> <p>100: Undefined.</p> <p>101: SMPTE 262M page/line multiplex system.</p> <p>110: Undefined.</p> <p>111: Undefined.</p>
610	REGEN CONTROL MODE	<p>When editing with two DSR-70A/70AP units, if you use the control panel for editing operation, select whether or not the timecode is automatically regenerated.</p> <p>AS&IN: In editing with this unit as the recorder, regardless of the settings of the TC INT/EXT switch and sub LCD menu item PRESET/REGEN, in assemble and insert editing, the timecode generator regenerates according to the timecode on the tape.</p> <p>ASSEM: In editing with this unit as the recorder, regardless of the settings of the TC INT/EXT switch and sub LCD menu item PRESET/REGEN, in assemble editing only, the timecode generator regenerates according to the timecode on the tape.</p> <p>MANU: Regardless of whether this unit is the recorder or player, the timecode generator operates in accordance with the settings of the TC INT/EXT switch and sub LCD menu item PRESET/REGEN.</p> <p>FULL: Regardless of the REMOTE/LOCAL switch setting, when any of the ASSEMBLE, VIDEO, AUDIO "CH1,1/2", AUDIO "CH2,3/4", and TC indicators is lit, the timecode generator regenerates according to the timecode played back from the tape.</p>

(Continued)

Extended Menu

Menu items in the 600s, relating to the time code generator (continued)

Item number	Item name	Settings
611	TC OUTPUT PHASE IN EE MODE	Select the timecode output mode for output from the TC OUT connector in E-E mode. MUTE: Mute the output. THRU: Output the timecode input to the TC IN connector as it is. V-IN: Output the timecode with the same phase as the input video signal phase. V-OUT: Output the timecode with the same phase as the output video signal phase.
612	TC OUTPUT MUTE IN SEARCH MODE	Select whether to mute the output from the TC OUT connector in search (jog/shuttle) mode. ON: Mute. OFF: Do not mute.
613	VITC OUTPUT	Select the time code to be output as VITC. OFF: Do not output VITC. TC: Output TC after converting it into VITC. VITC : Output VITC.

Menu items in the 700s, relating to video control

Item number	Item name	Settings
705	EDGE SUBCARRIER REDUCER MODE	Select whether to enable the edge subcarrier reducer (ESR). ON : Enable. OFF : Do not enable. When playing back a composite signal, set this to ON.
708	CHROMA PHASE ROTATION MODE	Select the phase rotation mode for chroma phase control. The effect of this setting applies to the output levels of all of the composite video, S video, SDI (when the DSBK-160A is installed) and component video (when the DSBK-170 is installed) signals. U/V: Select this setting when observing the unit's composite video output level using a composite vectorscope. PB/PR: Select this setting when observing the unit's component video output level using a component vectorscope.
710	INTERNAL VIDEO SIGNAL GENERATOR	Select the test signal to be output from the internal test signal generator. When SG is selected using the VIDEO IN button, the internal test signal generator operates to output the selected test signal. This signal can also be recorded. BB: Black burst signal CB100 (DSR-70AP only): 100% color bar signal CB75: 75% color bar signal The factory default setting is CB75 (DSR-70A)/CB100 (DSR-70AP).
713	VIDEO SETUP REFERENCE (DSR-70A only)	Select whether to remove the setup (7.5%) from the input analog video signals and whether to add the setup (7.5%) to the output analog video signals.
	Sub items	
	1 INPUT LEVEL	Whether to remove the setup from the input. 0.0%: Do not remove. 7.5%: Remove.
2 OUTPUT LEVEL	Whether to add the setup to the output. 0.0%: Do not add. 7.5%: Add.	
714	VIDEO ADJUST RANGE	Select the variable range of the VIDEO and CHROMA knobs when the PROCESS CONTROL item in the sub LCD menu is set to PANEL. -3 ~ +3: -3 dB to +3 dB WIDE: -∞ to +3 dB



Items 715 to 723 : Settings for controlling the video processing system according to the menu settings.

Item number	Item name	Settings
715	VIDEO GAIN CONTROL	Adjust the video output level. Default value: <u>200H</u>
716	CHROMA GAIN CONTROL	Adjust the chroma output level. Default value: <u>200H</u>
717	CHROMA PHASE CONTROL	Adjust the chroma phase. Default value: <u>80H</u>
718	SETUP LEVEL	Adjust the setup level (DSR-70A)/black level (DSR-70AP)). Default value: <u>200H</u>
723	INPUT VIDEO BLANK (DSR-70AP only)	Switch blanking on or off for the input video signal.
	Sub-item	
	1 LINE 335	BLANK: Blank the 335th line. THROU: Do not blank the 335th line.

Note

When you make settings for items 715 to 718, set the PROCESS CONTROL item in the sub LCD menu to SETUP. When set to SETUP, all controls on the front control panel are disabled.

Menu items in the 700s, relating to video control (continued)

Item number	Item name	Settings
729	CLOSED CAPTION BLANK (DSR-70A only)	Select whether to mute the closed caption signal to be superimposed on the 1st and 2nd fields of the output video signal.
	Sub items	
	1 FIELD 1	Select whether to mute the closed caption signal to be superimposed on the 1st field of the output video signal. OFF: Do not mute. ON: Mute.
	2 FIELD 2	Select whether to mute the closed caption signal to be superimposed on the 2nd field of the output video signal. OFF: Do not mute. ON: Mute.

Menu items in the 800s, relating to audio control

Item number	Item name	Settings
801	DIGITAL JOG SOUND	Select whether to adjust the audio playback speed during slow playback. OFF: Do not adjust the audio playback speed. ON: Adjust the audio playback speed.
802	DIGITAL AUDIO MUTE IN SHUTTLE MODE	Set the audio muting conditions during shuttle playback. OFF: Not muted. CUEUP: Muted during cue-up or preroll operations. FULL: Muted in shuttle mode.

(Continued)

Extended Menu

Menu items in the 800s, relating to audio control (continued)

Item number	Item name	Settings
808	INTERNAL AUDIO SIGNAL GENERATOR	Select the operation of the internal audio test signal generator. SILNC: Silent signal. 1kHz : 1-kHz, –20 dB FS sine wave signal. When you select SG as the audio input in the input selection section of the upper control panel, the audio test signal generated by the internal audio test signal generator is input.
811	AUDIO REFERENCE LEVEL	Select the audio reference level (headroom) for recording on tape. –12dB –16dB –18dB –20dB The factory default setting is –20 dB (DSR-70A)/–18 dB (DSR-70AP).
812	AUDIO OUTPUT LEVEL	Select the audio output reference level. +4dB 0dB –6dB
813	PEAK HOLD TIME	Set the peak hold time for the audio level meter in the range of OFF (no peak hold) to 1.5 seconds in 0.1 second steps.
814	OVER RANGE DISPLAY HOLD	Select whether to hold the audio level meter OVER display. OFF: Do not hold. ON: Hold.
821	AUDIO ATTENUATE WHEN DV TAPE PLAYBACK	When playing back a tape recorded in consumer DV format, select whether to attenuate the audio output level. OFF: Attenuate. ON: Do not attenuate.

Menu items in the 900s, relating to digital process

Item number	Item name	Settings
912	SEQUENTIAL RECORD INPUT SIGNAL	Selects the signal input method for sequential recording on the recorder and player. PAR: The video and audio signals you will record are input to the recorder and player separately. CAS: The video and audio signals you will record are input to the player, and input to the recorder as output signals from the player.

Extended Menu Operations

To use the extended menu, set basic menu item 099 MENU GRADE to ENHAN beforehand.

In the extended menu, you can carry out the same operations as in the basic menu except setting of sub-items.

To set sub-items

Operate as follows.

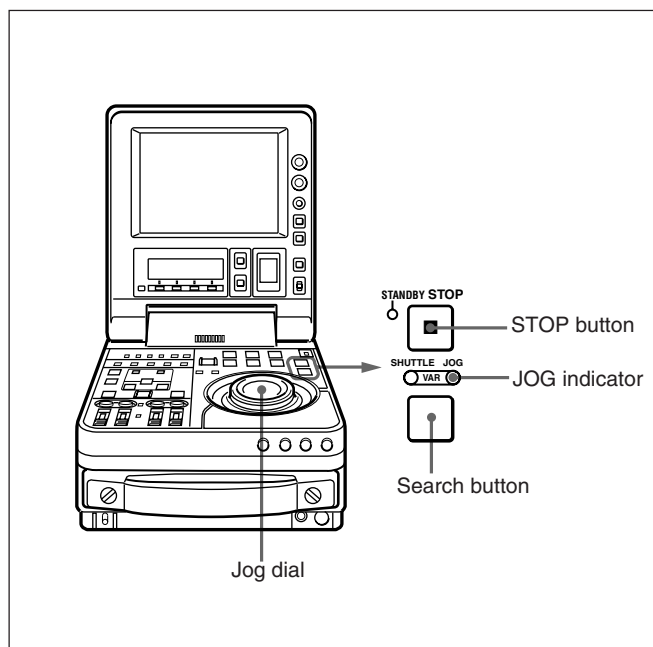

- 1 Confirm the JOG indicator lights. If not, set the unit to jog mode by pressing the jog dial.
- 2 Select the desired menu item.
For information about how to select a menu item, see “Changing the currently displayed menu item” (page 106).
- 3 Holding down the STOP button, turn the jog dial to select the desired sub-item.
- 4 Holding down the search button, turn the jog dial to change the value for the selected sub-item.

- 5 When the desired setting value is displayed, press the SET button.

This saves the new setting value, and the menu display disappears.

To abandon making a change

Press the MENU button before pressing the SET button.

The menu display disappears from the LCD monitor and sub LCD, without the new setting value being saved.

Connections and Settings

Reference Video Signals for Analog Signal Editing

In order to provide stable video and audio signals for analog editing, it is necessary for the built-in time base corrector (TBC) to operate correctly. To ensure this, input a reference video signal synchronized with the video signal to the REF. VIDEO IN connector and set the REF. VIDEO IN 75 Ω termination switch to ON.

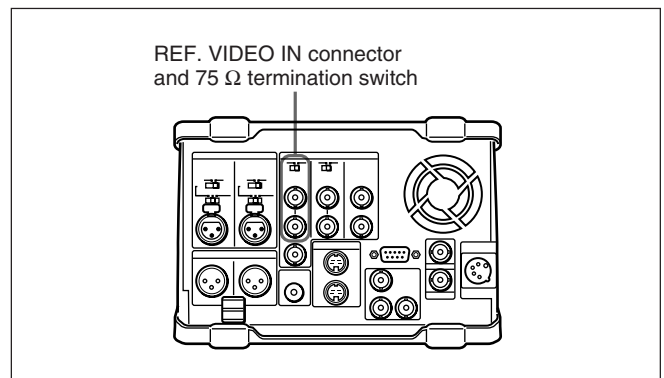

Connections for Cut Editing Using Two DSR-70A/70AP Units — i.LINK Connections (Optional DSBK-140/160A Required)

For a cut editing system using two DSR-70A/70AP units with an i.LINK interface, the following figure shows an example of the connections. Use the same configuration when dubbing signals in DVCAM format via an i.LINK interface.

Note

In this case, both of the recorder and player require the DSBK-140 or DSBK-160A board.

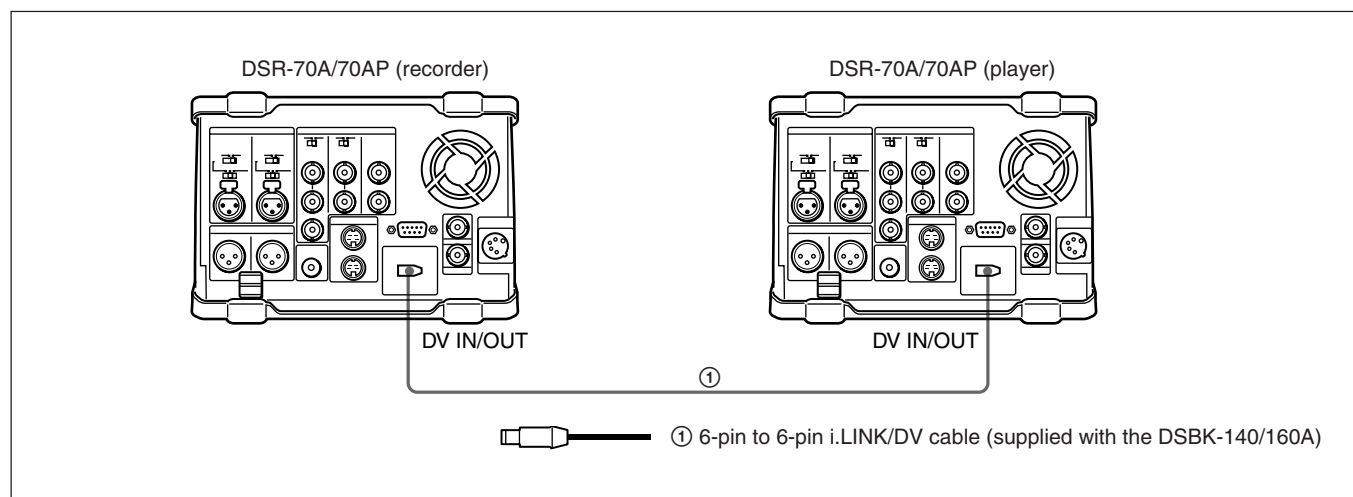

DSR-70A/70AP (recorder and player) settings

Switch/menu	Recorder	Player
REMOTE/LOCAL switch	LOCAL	REMOTE
Sub LCD menu general setting item REMOTE	i.LINK	i.LINK
Sub LCD menu home page input video/audio signal indication	i.LINK	Other than i.LINK

It is possible to combine two DSR-70A/70AP units using the optional BKNW- 225 Docking Kit (*see page 132*).

Also, for ease of carriage of the unit, you can use a shoulder belt (*see page 133*).

Connections for Digital Nonlinear Editing Using SDTI (QSDI) Interface (Optional DSBK-150 Required)

This unit can be connected to an ES-7 EditStation to configure a digital non-linear editing system. Using the SDTI (QSDI) interface, you can transfer video, audio, timecode, and other compressed data between this unit and the ES-7.

The unit supports ClipLink functions, enabling index pictures recorded on tape and ClipLink log data stored in cassette memory to be transferred to the ES-7 in an instant.

For an overview of the ClipLink function, see the appendix “ClipLink Guide” (page 147).

The following is a connection diagram for digital non-linear editing system in which this unit serves as the recorder.

For connections of the ES-7’s peripheral devices (the control panel, the disk unit, etc.) and the player, refer to your ES-7 Operating Instructions.

Note

In this case, the DSBK-150 SDTI (QSDI) Input/Output Board is required.

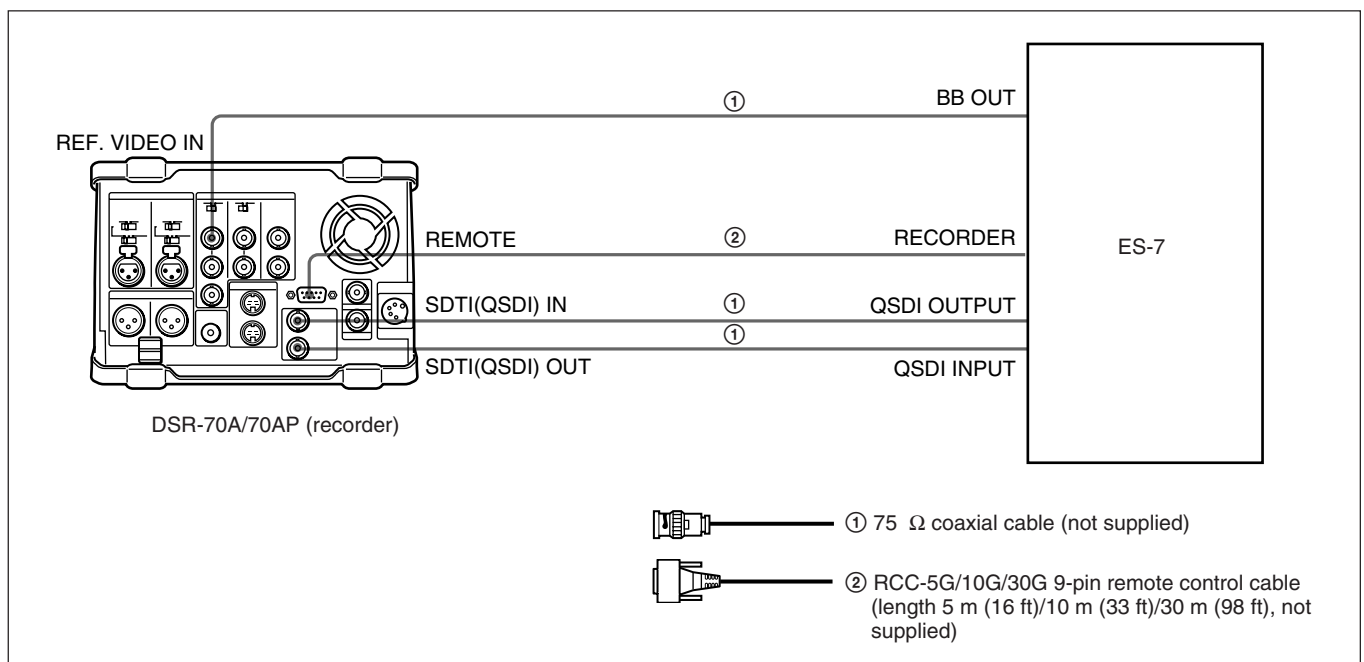

Settings on the DSR-70A/70AP

Switch	Setting
REMOTE/LOCAL switch	REMOTE
REF. VIDEO IN 75Ω termination switch	ON

Connections for Cut Editing Using SDI Interface (Optional DSBK-160A Required)

For a cut editing system using this unit together with a DNW-A25/A25P Betacam SX VCR using an SDI connection, the following figure shows an example of the connections. In this example, the DNW-A25/A25P is used as the recorder and this unit is used as the player.

Note

In this case, the DSBK-160A SDI/i.LINK/DV Input/Output Board is required.

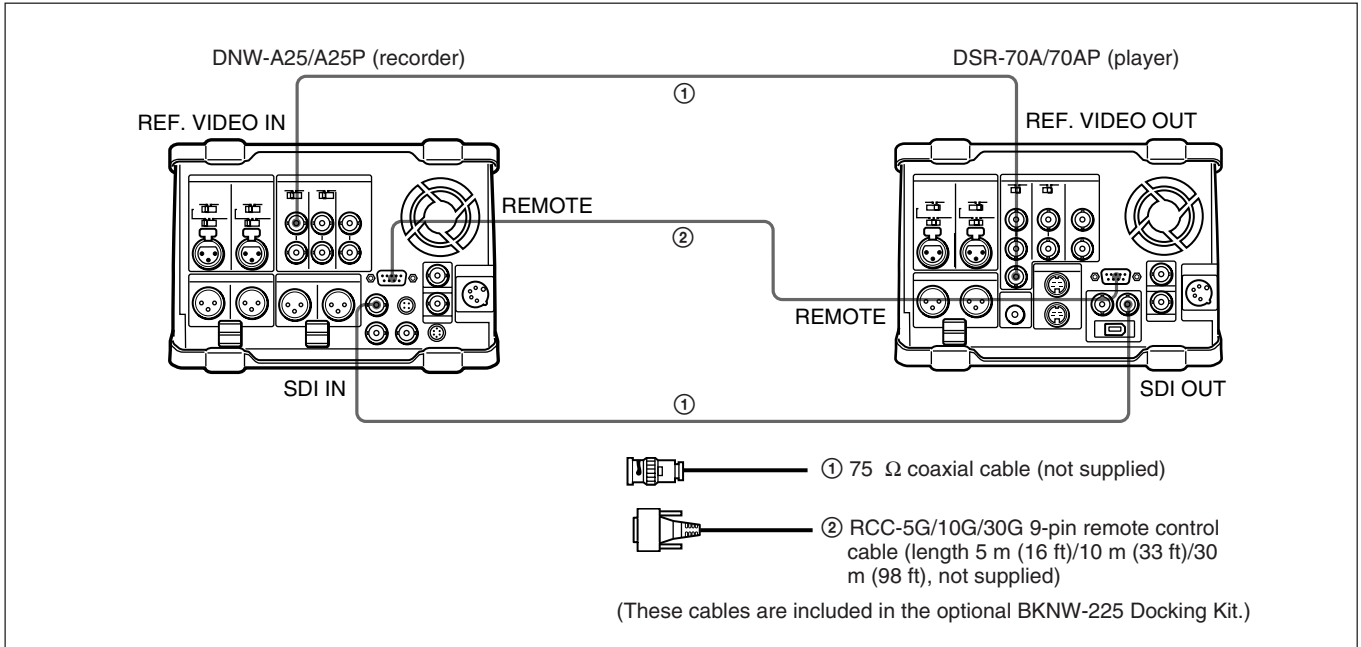

Settings on the DNW-A25/A25P

Switch	Setting
REMOTE/LOCAL switch	LOCAL
REF. VIDEO IN 75 Ω termination switch	ON

Settings on the DSR-70A/70AP

Switch	Setting
REMOTE/LOCAL switch	REMOTE

Settings Required When Connecting an External Editing Control Unit

When connecting an external editing control unit to this unit and using this unit as a recorder, make the following timecode settings on this unit and VCR constant and DIP switch settings on the editing control unit.

Timecode Settings on This Unit

Make the following timecode settings for this unit.

Switch/menu	Setting
TC INT/EXT switch	INT
Sub LCD menu PRESET/REGEN item (General settings page (1))	PRESET
Sub LCD menu F-RUN/R-RUN item (General settings page (1))	F-RUN

Settings on Editing Control Units

Make the following settings according to the editor model.

For FXE-100/120 (NTSC)

Set the VCR constants as follows.

Byte No.	1	2	3	4	5	6	7	8	9	10	11	12	13	14	15
Setting	80	13	00	96	05	05	03	80	0A	08	FE	00	80	5A	FF

For FXE-100P/120P (PAL)

Set the VCR constants as follows.

Byte No.	1	2	3	4	5	6	7	8	9	10	11	12	13	14	15
Setting	81	13	00	7D	05	05	02	80	0A	07	FE	00	80	4C	FF

For BVE-910/2000

Set the VCR constants as follows.

- When using the DSR-70A (NTSC)

Byte No.	Block 1								Block 2							
	1	2	3	4	5	6	7	8	9	10	11	12	13	14	15	
Setting	80	13	00	96	05	05	03	80	0A	08	FE	00	80	5A	FF	

- When using the DSR-70AP (PAL)

Byte No.	Block 1								Block 2							
	1	2	3	4	5	6	7	8	9	10	11	12	13	14	15	
Setting	81	13	00	7D	05	05	02	80	0A	07	FE	00	80	4C	FF	

For RM-450 (NTSC)

Set the VCR constants as follows.

- Left DIP switch

Switch No.	7	6	5	4	3	2	1	0
Setting	OFF	—	—	OFF	—	—	—	—

- Right DIP switch

Switch No.	7	6	5	4	3	2	1	0
Setting	OFF	—	OFF	ON	OFF	OFF	ON	ON

For RM-450CE (PAL)

Set the VCR constants as follows.

- Left DIP switch

Switch No.	7	6	5	4	3	2	1	0
Setting	OFF	—	—	OFF	—	—	—	—

- Right DIP switch

Switch No.	7	6	5	4	3	2	1	0
Setting	ON	—	OFF	ON	OFF	OFF	ON	ON

For BVE-800

Set the VCR constants as follows.

When using the DSR-70A (NTSC)

- SW2

Switch No.	1	2	3	4	5	6	7	8
Setting	ON	OFF	ON	ON	—	ON	ON	—

- SW3

Switch No.	1	2	3	4	5	6	7	8
Setting	OFF	ON	OFF	ON	—	ON	OFF	OFF

When using the DSR-70AP (PAL)

- SW2

Switch No.	1	2	3	4	5	6	7	8
Setting	ON	OFF	ON	ON	—	ON	ON	—

- SW3

Switch No.	1	2	3	4	5	6	7	8
Setting	ON	ON	OFF	ON	—	ON	OFF	OFF

For PVE-500

Use the factory settings as they are.

Connections for Component Analog Recording (Optional DSBK-170 Required)

The following shows connections for a system in which analog playback signals from another recorder or player are recorded on the DSR-70A/70AP. In this system, the video signals are analog component signals and the audio signals are recorded from audio channels 1 and 2.

Note

In this case, the DSBK-170 Analog Component Input/Output Board is required.

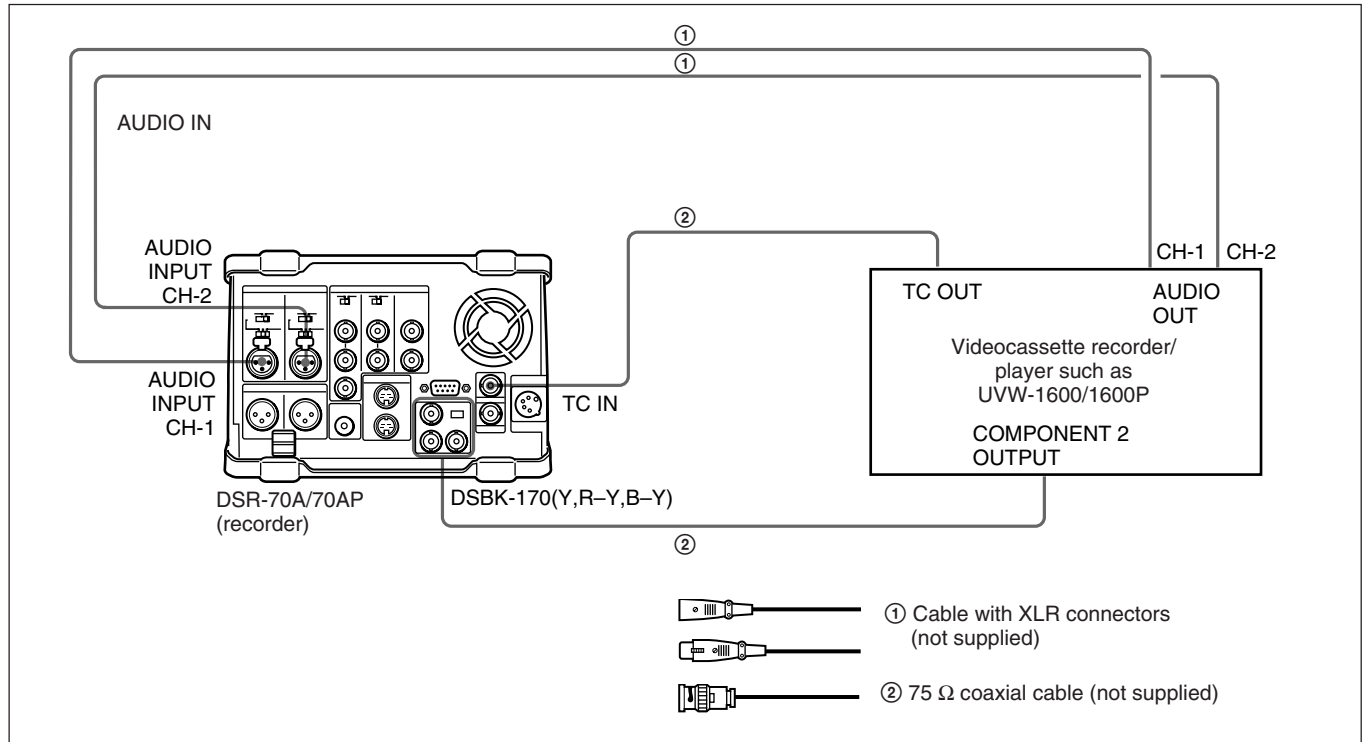

Settings on the DSR-70A/70AP

Switch	Setting
AUDIO INPUT CH-1/CH-2 level adjustment knobs	Normally +4 dBu
REMOTE/LOCAL switch	LOCAL (When controlling the unit from an editing controller, set to REMOTE.)
IN/OUT switch (on the DSBK-170)	IN

Connections for Sequential Recording Using Two Units

The following shows connections for sequential recording using two DSR-70A/70AP units. You can carry out two-unit sequential recording by inputting analog composite video signals and analog audio signals in the following two ways.

For information about how to carry out two-unit sequential recording, see “Sequential Recording Using Two Units” (page 43).

In the following, the controlling unit is referred to as the recorder and the controlled unit as the player.

Connections for sequential recording made by inputting external video and audio signals to both the player and recorder

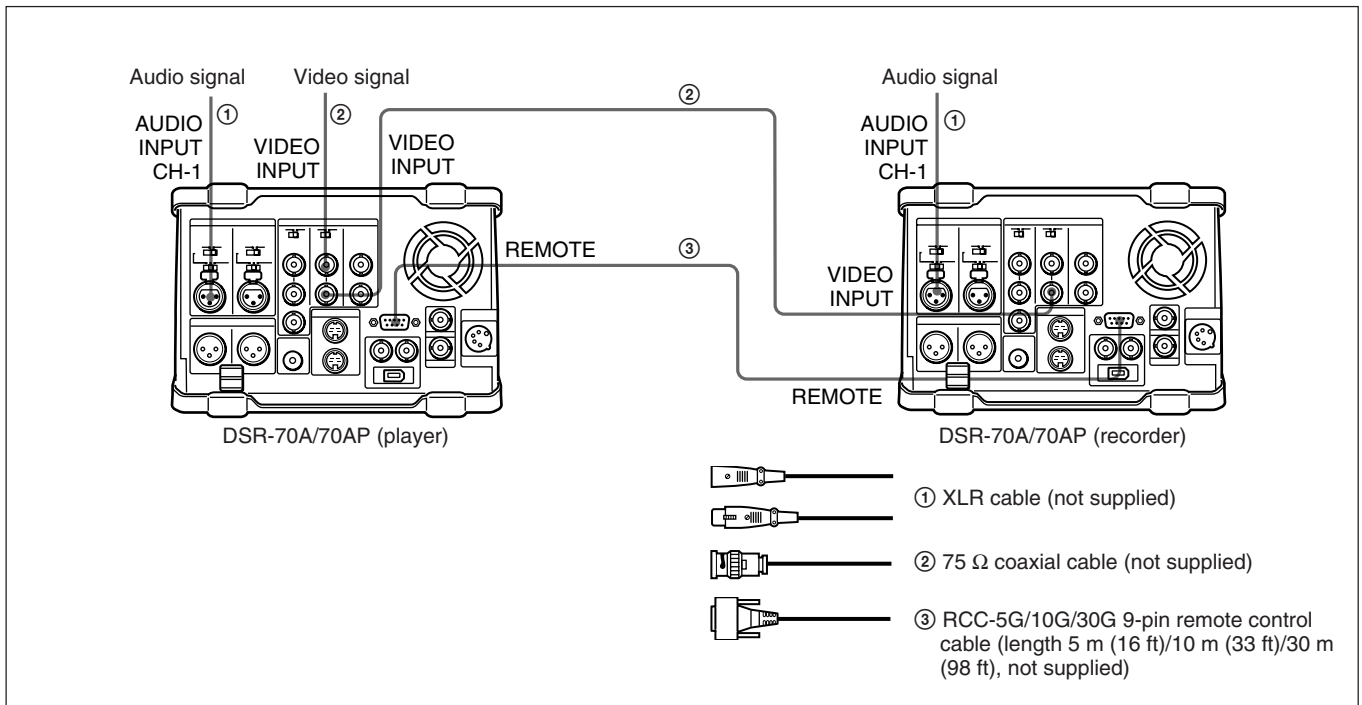

Player settings

Switch	Setting
REMOTE/LOCAL switch	REMOTE
VIDEO INPUT 75 Ω termination switch	OFF

Recorder settings

Switch/menu	Setting
REMOTE/LOCAL switch	LOCAL
VIDEO INPUT 75 Ω termination switch	ON
Setup menu item 014	Other than OFF
Setup menu item 912	PARALLEL

Connections for Sequential Recording Using Two Units

Connections for sequential recording made by inputting external video and audio signals to the player and inputting the video and audio signals output from the player to the recorder

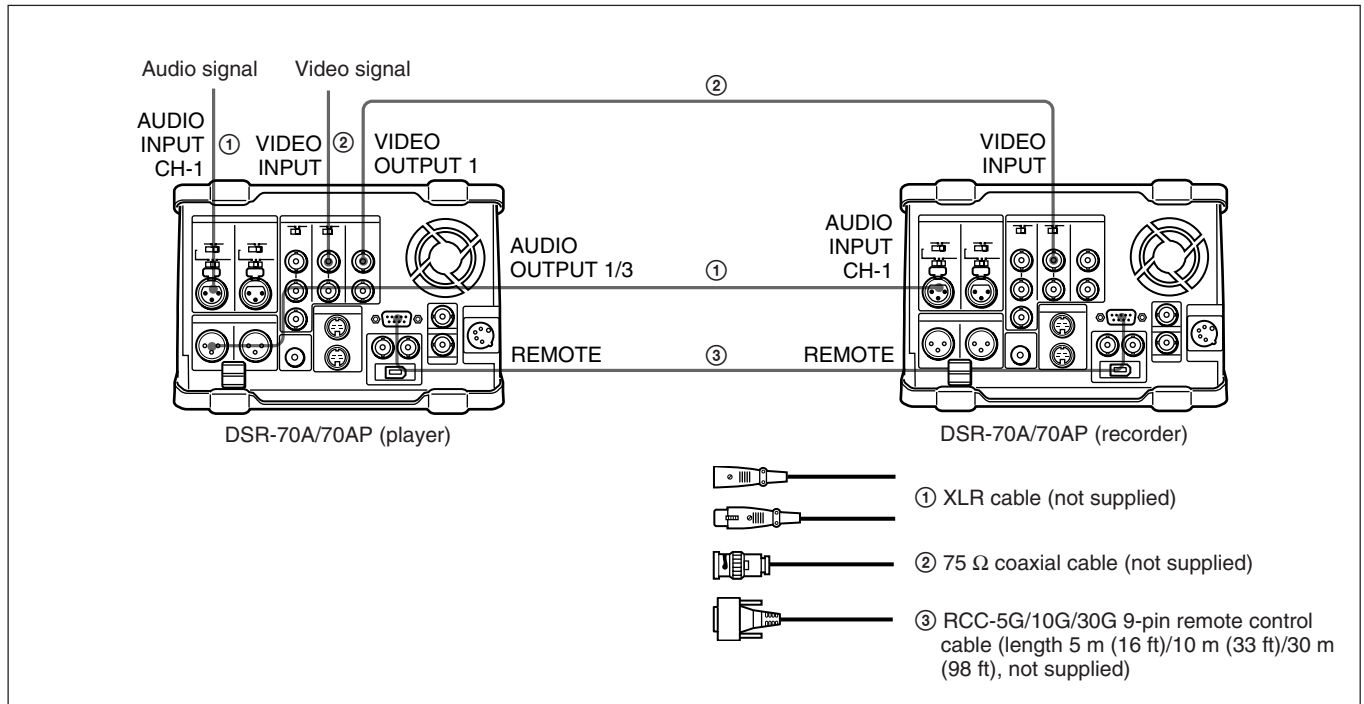

Player settings

Switch	Setting
REMOTE/LOCAL switch	REMOTE
VIDEO INPUT 75 Ω termination switch	ON

Recorder settings

Switch/menu	Setting
REMOTE/LOCAL switch	LOCAL
VIDEO INPUT 75 Ω termination switch	ON
Setup menu item 014	Other than OFF
Setup menu item 912	CASCADE

Connections for Parallel Recording Using Two Units

The following shows connections for parallel recording using two DSR-70A/70AP units. In the following, the controlling unit is referred to as the recorder and the controlled unit as the player.

For information about how to carry out two-unit parallel recording, see “Parallel Recording Using Two Units” (page 44).

The connections and settings to be made differ depending on the timecode to be used, as follows.

Inputting an external timecode to both the player and recorder

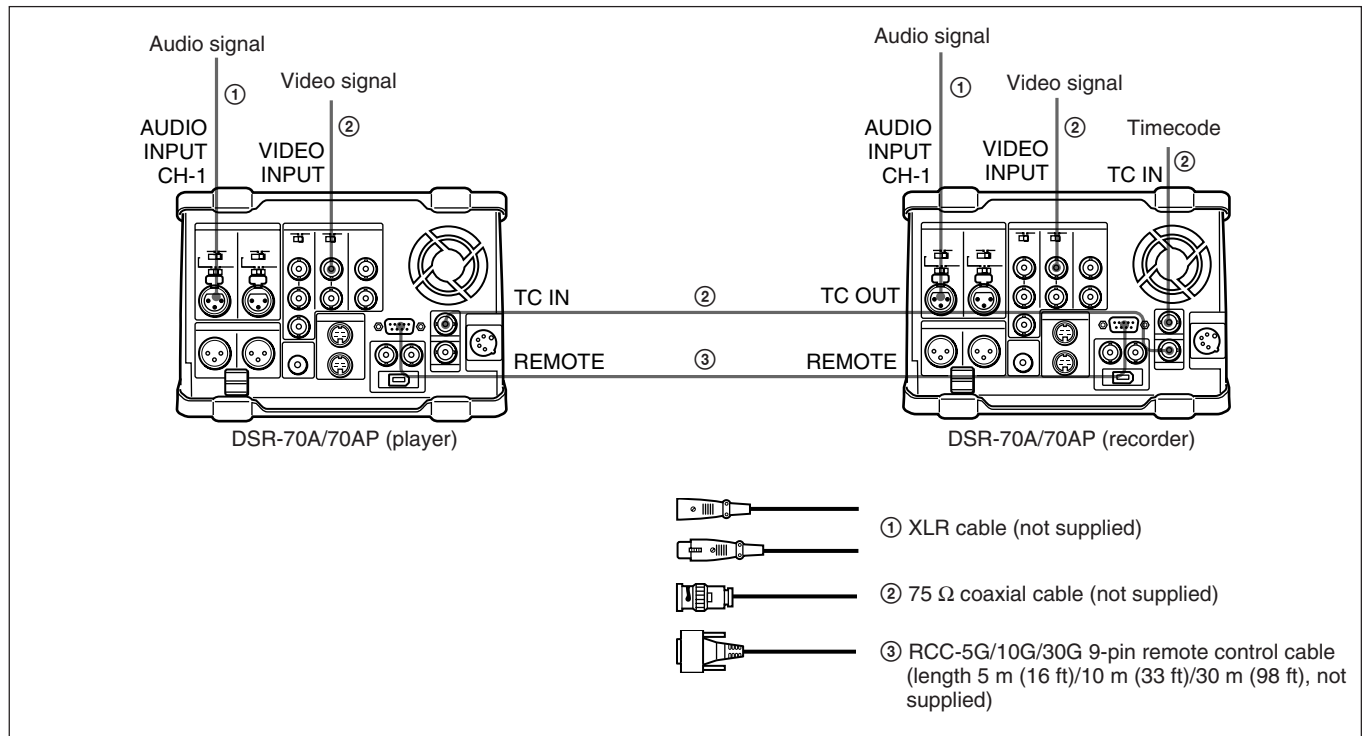

Player settings

Switch/menu	Setting
REMOTE/LOCAL switch	REMOTE
VIDEO INPUT 75 Ω termination switch	ON
TC INT/EXT switch	EXT
Sub LCD menu item PRESET/REGEN	REGEN
Setup menu item 201	ENA

Recorder settings

Switch/menu	Setting
REMOTE/LOCAL switch	LOCAL
VIDEO INPUT 75 Ω termination switch	ON
TC INT/EXT switch	EXT
Sub LCD menu item PRESET/REGEN	REGEN
Setup menu item 201	ENA
Setup menu item 611	THRU

Connections for Parallel Recording Using Two Units

Inputting the timecode generated by the recorder to the player

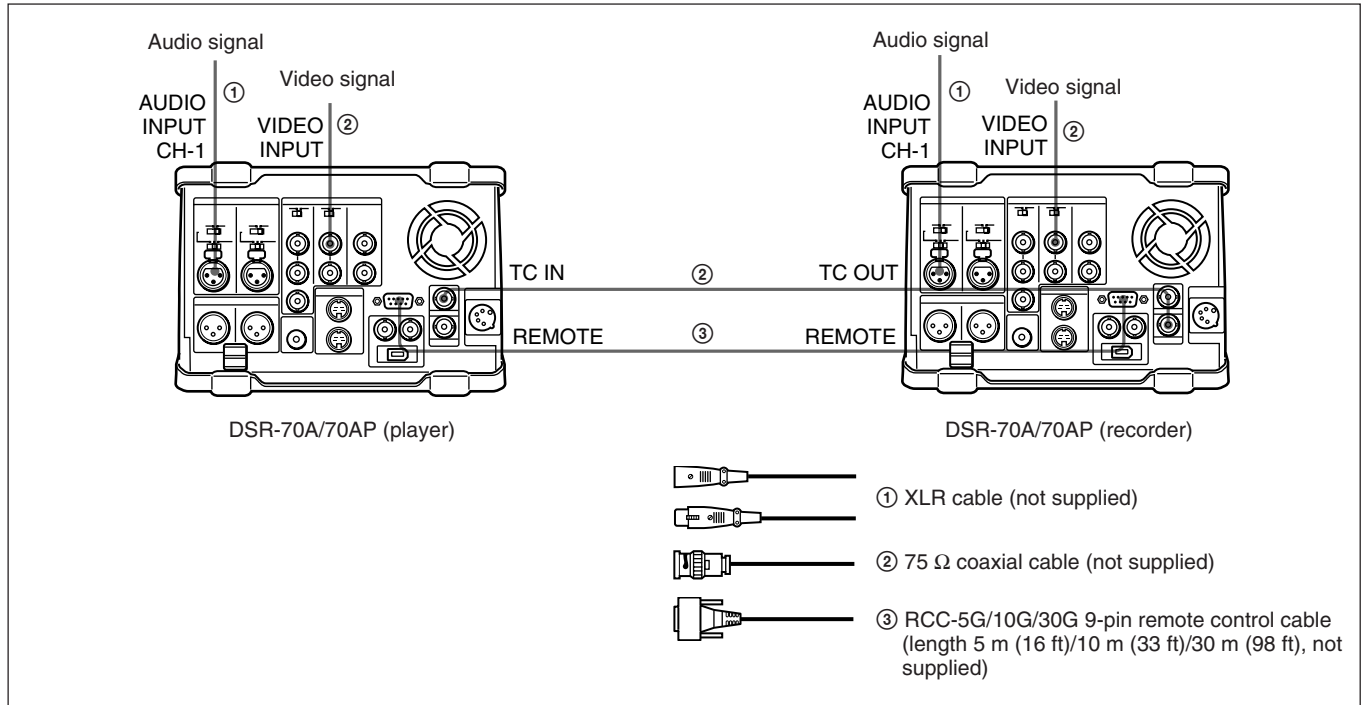

Player settings

Switch/menu	Setting
REMOTE/LOCAL switch	REMOTE
VIDEO INPUT 75 Ω termination switch	ON
TC INT/EXT switch	EXT
Sub LCD menu item PRESET/REGEN	REGEN
Setup menu item 201	ENA

Recorder settings

Switch/menu	Setting
REMOTE/LOCAL switch	LOCAL
VIDEO INPUT 75 Ω termination switch	ON
Setup menu item 201	ENA
Setup menu item 611	V-IN

Connections for Two-Unit Synchronous Playback

The following shows connections for synchronous playback using two DSR-70A/70AP units. In the following, the controlling unit is referred to as the recorder and the controlled unit as the player.

For information about how to carry out two-unit synchronous playback, see “Two-Unit Synchronous Playback” (page 57).

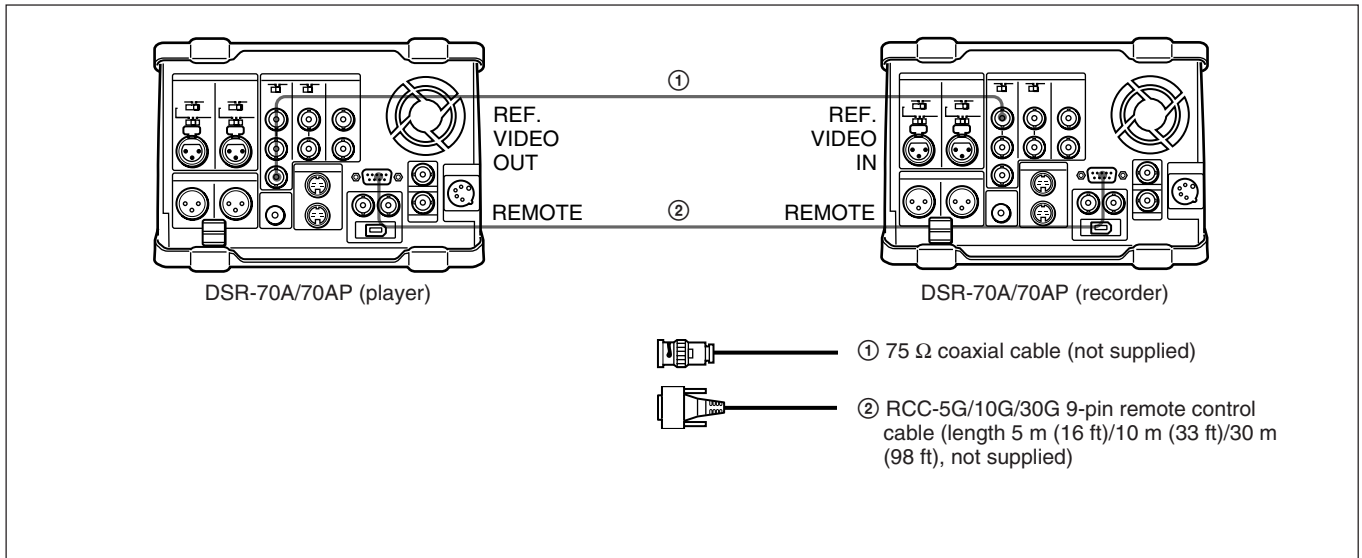

Player settings

Switch	Setting
REMOTE/LOCAL switch	REMOTE

Recorder settings

Switch/menu	Setting
REMOTE/LOCAL switch	LOCAL
Setup menu item 004	ON (Synchronize.) OFF (Do not synchronize.)
Setup menu item 305 (When synchronizing, synchronization accuracy)	ACCUR (± 0 frame) ROUGH (± 1 frame)
REF. VIDEO IN 75 Ω termination switch	ON

Connections for Two-Input Switched Video Recording (Optional DSBK-180/180P Required)

You can use the DSR-70A/70AP in combination with two DSR-300/300P or other camcorders, for two-input switched video recording.

The following figure shows the connections in this case.

Note

In this case, the DSBK-180/180P Dual Video Input Board is required.

For information about how to carry out two-input switched video recording, see page 46.

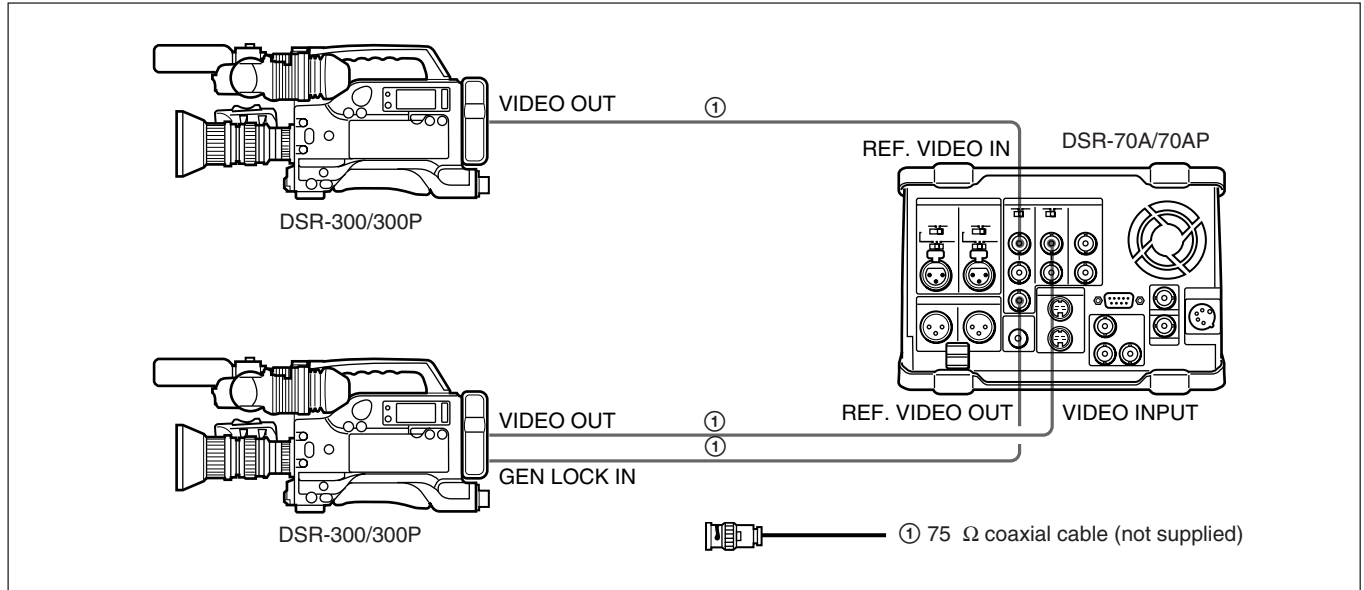

Notes

- The video signals output from the two camcorders must be synchronous. Make sure at least one of the two camcorders used has the Gen-lock (generator lock) function.
- When using a camcorder without the Gen-lock function, connect its output video to the REF. VIDEO IN connector of this unit.
- When long cables are used to connect two camcorders to this unit, a slight shift in phase between the video signals input from them may result.

For information about how to make phase adjustment in such a case, see “To adjust the output video signal phases” (page 48).

Settings on the DSR-70A/70AP

Switch	Setting
REF. VIDEO IN 75 Ω termination switch	ON
VIDEO INPUT 75 Ω termination switch	ON

Connections for Digitally Dubbing Signals in DVCAM Format (Optional DSBK-140/150/160A Required)

You can use this unit to digitally dub signals in DVCAM format automatically from the beginning of the tape to the end, through an i.LINK or SDTI(QSDI) interface.

the i.LINK interface (DSBK-140 or DSBK-160A)

Make the same connections and settings as described in the section “Connections for Cut Editing Using Two DSR-70A/70AP Units” (page 120).

For information about how to carry out digital dubbing, see “Digitally Dubbing Signals in DVCAM Format” (page 50).

Connecting two DSR-70A/70AP units using the SDTI(QSDI) interface (DSBK-150 SDTI (QSDI) Input/Output Board)

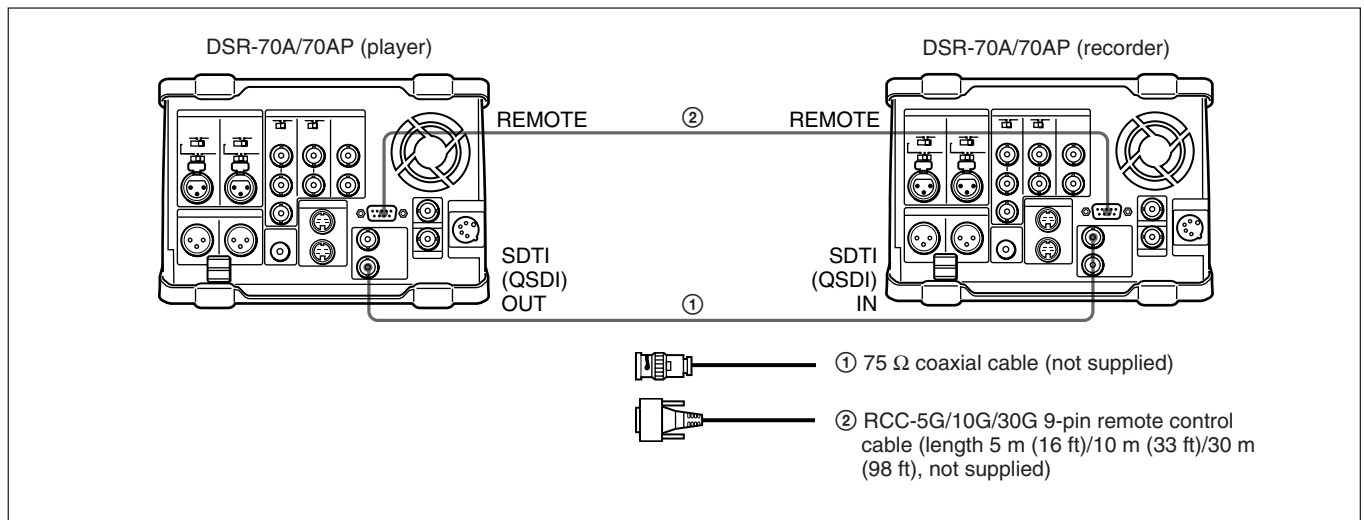

Player settings

Switch	Setting
REMOTE/LOCAL switch	REMOTE

Recorder settings

Switch	Setting
REMOTE/LOCAL switch	LOCAL

When connecting this unit with a DSR-60/60P/80/80P/85/85P unit using the SDTI(QSDI) interface (DSBK-150)

Replace the DSR-70A/70AP (player) shown in the above diagram with a DSR-60/60P/80/80P/85/85P unit and make the same connections as shown above.

The SDTI(QSDI) interface connector of the DSR-85/85P/1500/1500P/1600/1600P/1800/1800P/2000/2000P is marked “QSDI(OUTPUT).”

Combining Two VCRs

The following figure shows how to combine two VCRs using the optional BKNW-225 Docking Kit.

For more information, refer to the operation guide for the BKNW-225.

Caution

If you combine two units or separate the combined units incorrectly, the units may fall down and cause body injury.

Follow the procedures described below for separation or combination.

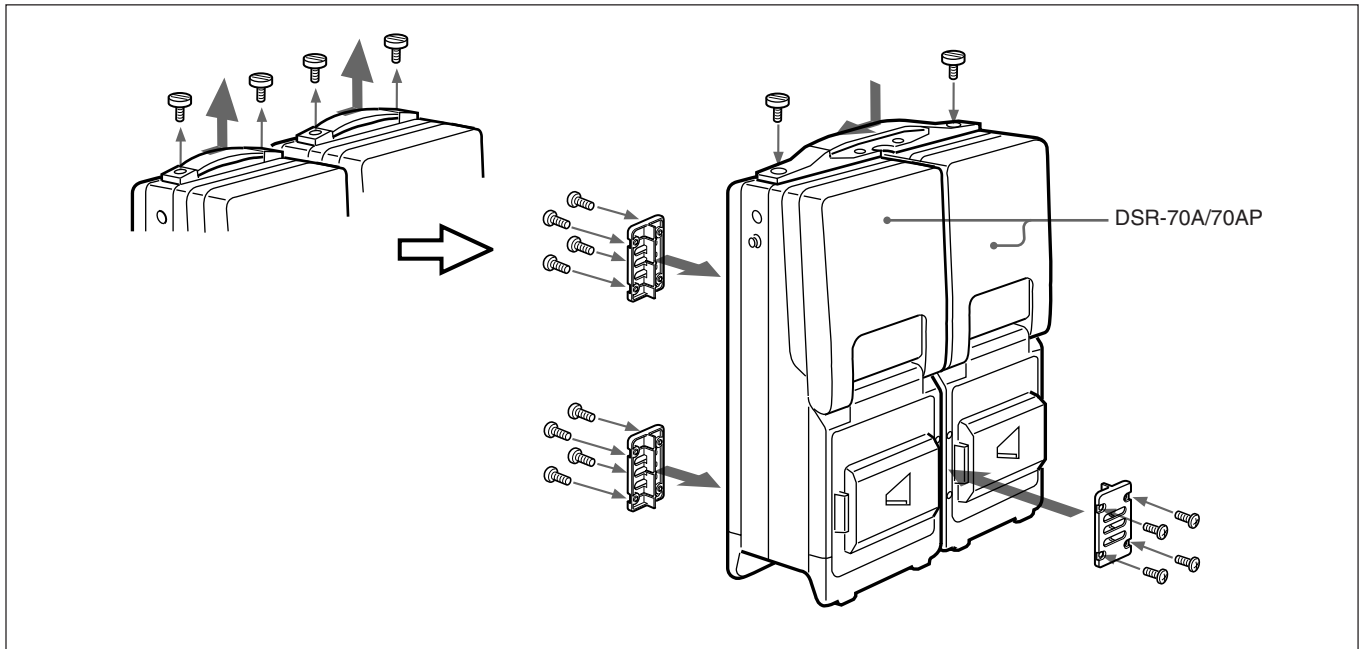

How to attach handle

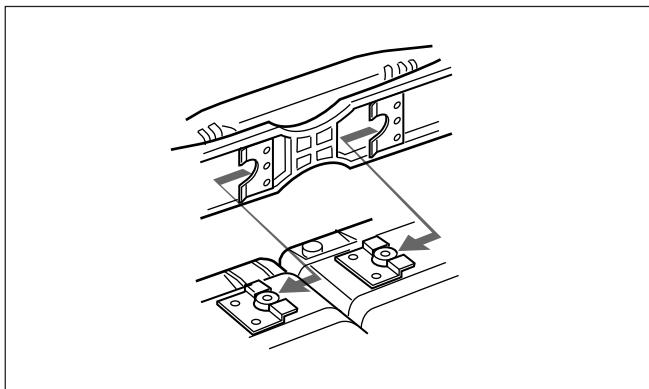

Attaching the fixing plates

If you want to be able to combine two units or separate the combined units without using tools such as screwdrivers, replace the screws (M3) that hold the fixing plate in place with the supplied coin screws.

Note

The coin screws (M4) for fixing the handle have washers. When you remove the handle, keep the screws and washers by fastening them to the handle.

To separate the combined VCRs

Reverse the steps for combination in a horizontal position.

Using the Shoulder Belt

The following figures show how to fit the supplied shoulder belt.

Caution

If you fit the shoulder belt incorrectly, the unit may fall down and cause body injury. Follow the procedures described below to fit or remove the shoulder belt.

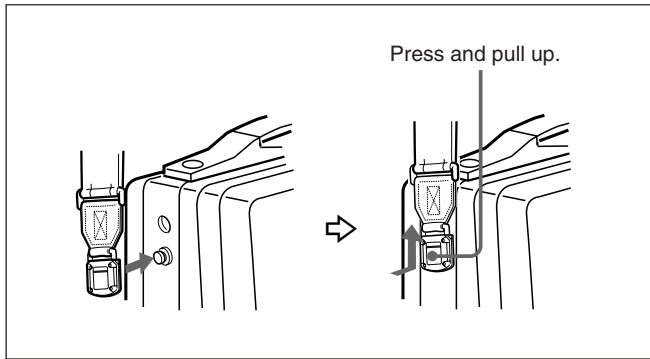

To remove the shoulder belt

While pressing down the indication PRESS, move the clip downwards to release it.

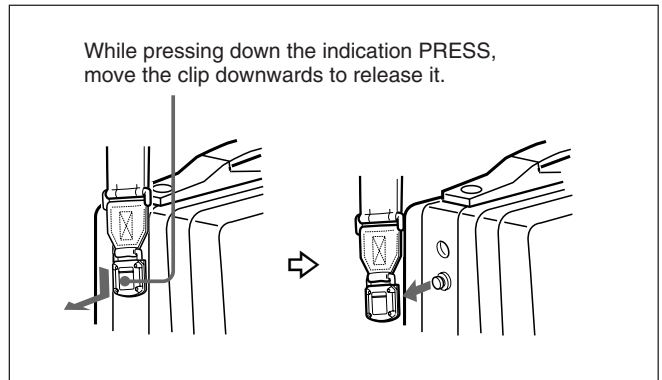

Maintenance and Troubleshooting

Condensation

If you move the unit suddenly from a cold to warm location, or if you use it in a very humid place, moisture from the air may condense on the head drum. This is called condensation, and if a tape is run in this state, the tape may stick to the drum and can be easily damaged. To lessen the risk of this occurring, this unit is equipped with a condensation detection system.

If condensation occurs while the unit is operating:

The alarm message “MOISTURE HAS BEEN DETECTED.” appears on the monitor screen, and the alarm message “HUMID!” in the sub LCD. At the same time the unit ejects the cassette automatically. If this happens, leave the unit’s power on and wait until the alarm messages disappear.

If the condensation alarm messages appear immediately after powering on:

Leave the unit powered on and wait until the alarm messages disappear. You cannot load a cassette into the unit while the alarm messages are being displayed. Once the alarm messages disappear, the unit is ready for use.

Head Cleaning

Always use the DVM12CL (mini-size) or DV12CL (standard size) Cleaning Cassette to clean the video and audio heads. You can run the cleaning cassette for 10 seconds per cleaning operation. Follow the instructions for the cleaning cassette, as inappropriate use of the cleaning cassette can damage the heads.

To clean the heads

Insert the cleaning cassette. This automatically starts cleaning. You cannot operate any tape transport control buttons other than the EJECT button during the cleaning operation.

After about 10 seconds, the cleaning cassette will be automatically ejected.

Periodic Maintenance

Digital hours meter

The digital hours meter can display seven items of information in the sub LCD, in corresponding display modes, about the operational history of the unit. Use it as a guide in scheduling periodic maintenance.

For periodic maintenance, consult your Sony dealer.

Display modes of the digital hours meter

H01: OPERATION mode

Displays the total number of hours the unit has been powered on in units of 1 hour.

H02: DRUM RUNNING mode

Displays the total number of hours the drum has run with tape threaded in units of 1 hour.

H03: TAPE RUNNING mode

Displays the total number of hours the unit has been in fast forward, rewind, playback, search, recording or editing (except for stop and still) mode in units of 1 hour.

H04: THREADING mode

Display the total number of times tape has been threaded in the unit.

H12: DRUM RUNNING mode (resettable)

Same as H02 except that the count is resettable. This can be used as a guide in determining when to replace the drum.

H13: TAPE RUNNING mode (resettable)

Same as H03 except that the count is resettable. This can be used as a guide in determining when to replace such components as stationary heads and pinch roller.

H14: THREADING mode (resettable)

Same as H04 except that the count is resettable. This can be used as a guide in determining when to replace, for example, the threading motor.

To display the hours meter

Press the MENU button, then turn the jog or shuttle dial to display the required item in the LCD monitor and sub LCD.

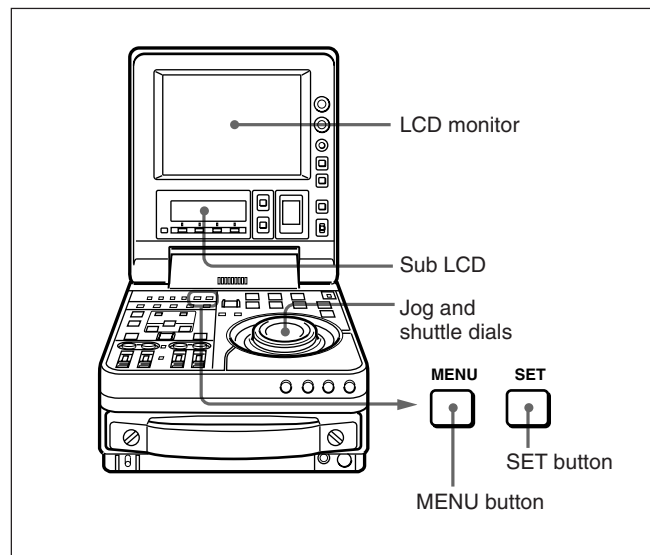

To exit from the hours meter

Press the MENU button or SET button.

Troubleshooting

If an alarm message appears on the monitor (this unit's LCD monitor or the video monitor connected to this unit) or in the sub LCD, or if the unit appears to be

malfunctioning, please check the following before contacting your Sony dealer.

Tape problems		
Symptom	Cause	Remedy
Recording is not possible.	The cassette's REC/SAVE switch is set to SAVE. ^{a)}	Set the REC/SAVE switch to REC.
The unit's tape transport control buttons (PLAY, F FWD, REW, etc.) do not work.	The REMOTE/LOCAL switch is set to REMOTE and setup menu item 006 (LOCAL FUNCTION ENABEL) is set to ST&EJ or DIS. ^{a)}	Set the REMOTE/LOCAL switch to LOCAL and setup menu item 006 to ENA.
	No cassette is loaded. ^{a)}	Insert a cassette.
The NO EDIT indication appears in the sub LCD.	The recording mode selected on this unit does not coincides with that of the loaded tape. ^{a)}	<ul style="list-style-type: none"> Set the unit for the same recording mode as with the tape. When your current purpose is recording, you can use the tape currently loaded in the unit.
	The recording format of the currently loaded tape is "DV." ^{a)}	<ul style="list-style-type: none"> If you are using the unit for recording, you can use the currently loaded tape. You can use the currently loaded tape as a source tape for playback and editing. You cannot use the tape as a recording tape for editing.

Time data problems		
Symptom	Cause	Remedy
Cannot freely set the time data's initial value.	The TC INT/EXT switch is set to EXT ^{a)} .	Set the TC INT/EXT switch to INT.
	Sub LCD menu item PRESET/REGEN is set to REGEN.	Set the sub LCD menu item PRESET/REGEN to PRESET.
	CNT is selected as the time data type to be displayed. (The time data indication CNT is displayed in the sub LCD.) ^{a)}	Press the COUNTER SELECT button to display the time data indication TC or UB.
	The REMOTE/LOCAL switch is set to REMOTE and setup menu item 006 (LOCAL FUNCTION ENABLE) is set to ST&EJ or DIS. ^{a)}	Set the REMOTE/LOCAL switch to LOCAL and setup menu item 006 to ENA.
The tape is running, but the time data indication is not shown in the sub LCD.	The HOLD button on the display panel has been pressed.	Press the button once again to exit the time code preset mode.
	The time data indication UB is displayed in the sub LCD.	Press the COUNTER SELECT button to display the time data indication CNT or TC.

Input problems		
Symptom	Cause	Remedy
It is not possible to record an SDTI signal.	No SDTI signal is input to the unit. ^{a)}	Connect an SDTI (QSDI) signal to the SDTI (QSDI) IN connector.

a) In these states, alarm messages appear on the monitor screen and in the sub LCD.

Troubleshooting

Monitor problems		
Symptom	Cause	Remedy
Data is not superimposed on the monitor screen.	The sub LCD menu item CHARACTER is set to OFF.	Set the sub LCD menu item CHARACTER to ON.
	Monitor is not connected to the VIDEO OUTPUT 2 (SUPER) connector of this unit.	Connect the monitor to the VIDEO OUTPUT 2 (SUPER) connector. (You must make this connection to display any type of text on the monitor.)
The image on the monitor's screen is too bright.	The 75 Ω termination switch for video input on the monitor is in the OFF position or a 75 Ω terminator is not fitted to its video input connector.	Set the 75 Ω termination switch to ON or connect a terminator.
The image on the monitor's screen is too dark.	In a video signal loop-through connection of video monitors, 75 Ω termination switches for video input on monitors other than the loop-end monitor are in the ON position.	Set the 75 Ω termination switches to OFF on all monitors other than the loop-end monitor .
The image is too dark when recording a composite video signal.		

Audio problems		
Symptom	Cause	Remedy
The AUDIO INPUT level adjustment knobs do not work.	The AUDIO INPUT PRESET/VARIABLE switch is set to PRESET.	Set the AUDIO INPUT PRESET/VARIABLE switch to VARIABLE.
Sliding the PB AUDIO level adjustment sliders does not change the playback audio output level.	PB AUDIO PRESET/VARIABLE switch is set to PRESET.	Set the PB AUDIO PRESET/VARIABLE switch to VARIABLE.

Editing problems		
Symptom	Cause	Remedy
Execution of video editing in insert mode causes subcode data recorded on tape other than time code data to disappear from tape.	This phenomenon cannot be avoided with an editing system using this unit as the recorder.	

Error Messages

This unit is provided with a self-diagnostic function that detects internal abnormalities. When it detects an abnormality, it outputs an error message to the monitor screen and indicates an error code in the sub LCD.

Note

To display error messages on the monitor screen, set the sub LCD menu item CHARACTER to ON.

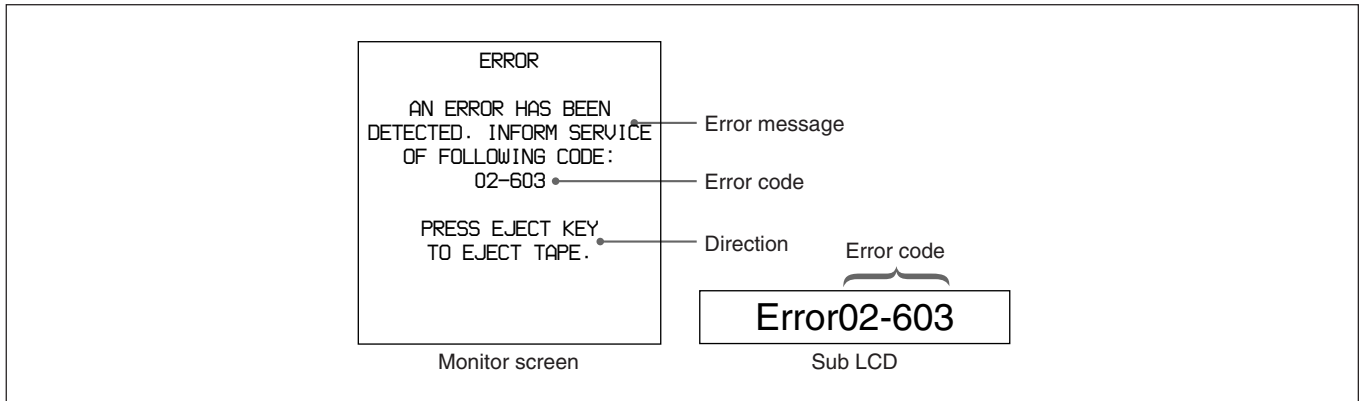

Alarm Messages

When a setting, connection or operation error has been made, or when a problem such as condensation on heads has occurred, the unit outputs alarm messages

such as the ones shown below to the monitor screen and the sub LCD.

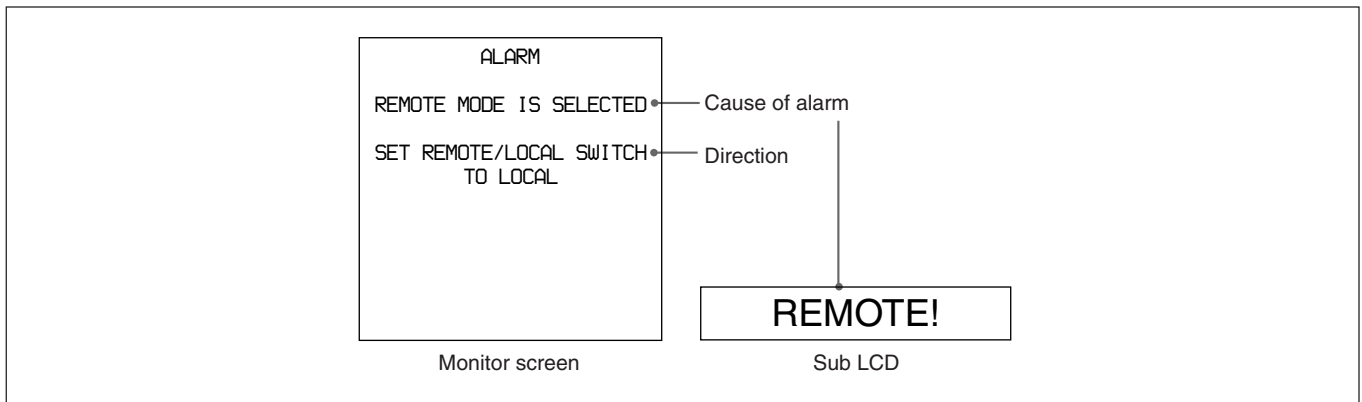

If an alarm message appears, follow the direction indicated under the message on the monitor screen. To display alarm messages on the monitor screen, set the sub LCD menu item CHARACTER to ON, and setup menu items 016 (ALARM) and 106 (REFERENCE SYSTEM ALARM) to ON or LIMIT.

For details of setup menu operations, see Chapter 7 “Setup Menu” (page 103).

Troubleshooting

List of alarm messages and associated directions

Here is a list of alarm messages and associated directions to appear on the monitor screen. It also shows the corresponding alarm messages to appear on the sub LCD of this unit.

In this list the “Causes” of alarm are arranged in alphabetic order of the first word of their phrases.

Alarm messages and associated directions

Alarm message on monitor screen Cause	Direction	Alarm message on sub LCD
A cleaning tape has been inserted.	The tape will automatically be ejected after cleaning is completed.	Cleaning Tp
A non-standard signal is being used for input video.	Use a standard signal.	VIN NON-STD
A non-standard ref. signal is being used for REF. VIDEO.	Use a standard signal.	REF NON-STD
Abnormal settings selected in setup menu.	Correct the setup menu settings. Contact your Sony dealer if this alarm message appears again after making corrections.	ILL. SETUP
Audio mixing mode cannot be changed during recording.	—	REC mode!
Audio not editable on this tape.	Use a tape recorded in 2-channel (48 kHz) or 4-channel (32 kHz) mode.	2CH/32kHz! Fs 44.1kHz!
	Use a tape having audio signals recorded in locked mode.	UNLOCK mode
Audio REC mode selection different from audio on tape.	Select the same audio recording mode as that of the tape.	A mode err
Audio REC (recording) mode cannot be changed during recording.	—	REC mode!
Counter mode is selected.	Use the COUNTER SELECT button to display “TC” or “U-BIT” on the sub LCD.	CNT mode!
Input selection cannot be changed in REC (recording) mode.	—	REC mode!
Input signal does not conform to DVCAM/DV format.	—	Unknown Sig
Input signal is 625/50. (For DSR-70A)	—	625/50 sig! (For DSR-70A)
Input signal is 525/60. (For DSR-70AP)	—	525/60 sig! (For DSR-70AP)
Input video is not detected.	Check the input video signal indication in the sub LCD and supply an appropriate video signal.	No INPUT!
Input video signal does not synchronize with REF. VIDEO signal.	Use a common reference signal or connect the recorder REF. VIDEO OUT connector to the player REF. VIDEO IN connector.	ILL. REF!
	Note When connecting the recorder REF. VIDEO OUT connector to the player REF. VIDEO IN connector, set extended menu item 308 to N-STD.	
Key inhibit mode is selected.	Set the sub LCD menu item KEY INHI to OFF.	KEY INHI.
Moisture has been detected.	Keep the power on and wait until this alarm message disappears.	HUMID!

Alarm messages and associated directions (Continued)

Alarm message on monitor screen Cause	Direction	Alarm message on sub LCD
No cassette in VTR.	Load a cassette.	No Cass.!
Rec inhibit mode is selected.	Set the REC INHI switch on the control panel to OFF.	REC INHI.!
Record inhibit plug on the cassette is set to inhibit.	Set the REC/SAVE switch on the cassette to REC.	REC INHI.!
Remote mode is selected.	Set the REMOTE/LOCAL switch on the control panel to LOCAL.	REMOTE!
Tape cannot be replayed.	Use a tape recorded in 525/60 format. (For DSR-70A)	625/50 Tape (For DSR-70A)
	Use a tape recorded in 625/50 format. (For DSR-70AP)	525/60 Tape (For DSR-70AP)
Tape end has been detected.	Use a new cleaning tape.	Tape end!
Tape not editable.	Use a tape recorded in DVCAM format.	Not DVCAM!
	Use a tape recorded in 525/60 format. (For DSR-70A)	625/50 Tape (For DSR-70A)
	Use a tape recorded in 625/50 format. (For DSR-70AP)	525/60 Tape (For DSR-70AP)
Tape not recordable.	Use a DVCAM/DV ME tape.	REC INHI.!
Tape not usable.	Use DVCAM/DV/DVCPRO (25M) tape.	ILL. Tape!
TC EXTERNAL is selected.	Set the TC INT/EXT switch on the control panel to INT.	TC EXT!
TCG REGEN mode is selected.	Set the sub LCD menu item PRESET/REGEN to PRESET.	REGEN mode!
TCG RUN mode is set to REC RUN.	Set the sub LCD menu item F-RUN/R-RUN to F-RUN.	REC RUN!

Appendixes

Specifications

General

Power requirements	12 V DC
Power consumption	46 W (with no optional boards installed)
	DSBK-140: 2.2 W
	DSBK-150: 3 W
	DSBK-160A: 5 W
	DSBK-170: 0 W
	DSBK-180: 5 W
Operating temperature	0°C to 40°C (32°F to 104°F)
Storage temperature	-20°C to +60°C (-4°F to +140°F)
Humidity	80% or less (Operating) 90% or less (Storage)
Mass	5.8 kg (12 lb 12 oz)
Dimensions (w/h/d)	211 × 149 × 443 mm (8 3/8 × 5 7/8 × 17 1/2 inches)

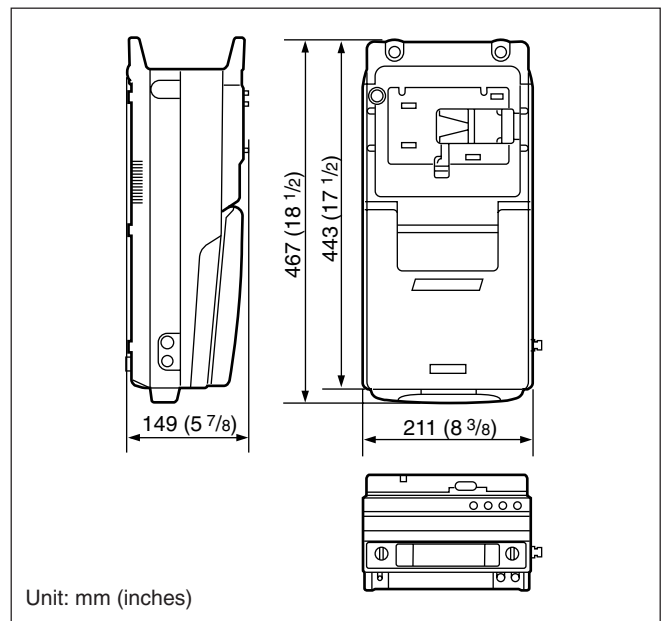

Tape transport control system

Tape speed	28.193 mm/s (DSR-70A) 28.221 mm/s (DSR-70AP)
Recording/playback time	184 min or more (PDV-184ME) 40 min or more (PDVM-40ME)
Fast forward/rewind time	3 min or less (PDV-184ME) 1 min or less (PDVM-40ME)
Search speed	Up to 32 times normal in both directions

Specifications

Video performance

Band width	Composite (DSR-70A): 30 Hz to 4.2 MHz ± 1.0 dB (Y) Composite (DSR-70AP): 25 Hz to 4.8 MHz ± 1.0 dB (Y) S-Video (DSR-70A): 30 Hz to 5.0 MHz ± 1.0 dB (Y), 5.75 MHz $+1.0/-3.0$ dB (Y) (TM) S-Video (DSR-70AP): 25 Hz to 5.0 MHz ± 1.0 dB (Y), 5.5 MHz $+1.0/-2.0$ dB (Y), 5.75 MHz $+1.0/-3.0$ dB (Y) (TM) Component (DSR-70A): 30 Hz to 5.0 MHz ± 1.0 dB (Y), 5.5 MHz $+1.0/-2.0$ dB (Y), 5.75 MHz $+0/-3.0$ dB (Y) (TM), 30 Hz to 1.3 MHz ± 1.0 dB (C), 1.5 MHz $+1.0/-5.0$ dB (C) Component (DSR-70AP): 25 Hz to 5.0 MHz ± 1.0 dB (Y), 5.5 MHz $+1.0/-2.0$ dB (Y), 5.75 MHz $+1.0/-3.0$ dB (Y) (TM), 25 Hz to 1.5 MHz ± 1.0 dB (C), 2.0 MHz $+1.0/-2.0$ dB (C)
S/N	Composite I/O (Y): 53 dB or more S-Video I/O (Y): 55 dB or more Component I/O (Y): 55 dB or more
Y/C delay	30 ns or less
K-factor	2.0% or less (K2T, KPb)

Processor adjustment range

Video level	± 3 dB/ $-\infty$ to 3 dB selectable
Chroma level	± 3 dB/ $-\infty$ to 3 dB selectable
Setup/Black level	± 30 IRE/210 mV
Chroma phase	$\pm 30^\circ$

Audio performance

Frequency response	2 ch (48 kHz/16 bit): 20 Hz to 20 kHz $+0.5/-1.0$ dB 4 ch (32 kHz/12 bit): 20 Hz to 14.5 kHz $+0.5/-1.0$ dB
Dynamic range	87 dB or more
Distortion	0.07% (48 kHz) or less

Input connectors

Digital input

DV IN/OUT (When using optional DSBK-140 or DSBK-160A board)	6-pin IEEE1394 connector $\times 1$
SDTI (QSDI) IN (When using optional DSBK-150 board)	BNC type $\times 1$, SDTI (QSDI) format (270Mbps)
SDI IN (When using optional DSBK-160A board)	BNC type $\times 1$, SMPTE 259M (DSR-70A)/ITU-R BT.656 (DSR-70AP), SDI format (270Mbps)

Analog video input

VIDEO INPUT	BNC type $\times 2$ (loop-through), composite, 1.0 Vp-p, 75 Ω , sync negative
REF. VIDEO IN	BNC type $\times 2$ (loop-through), black burst, 0.286 Vp-p (DSR-70A) or 0.3 Vp-p (DSR-70AP), 75 Ω , sync negative
S VIDEO IN	DIN 4-pin $\times 1$ Y: 1.0 Vp-p, 75 Ω , sync negative C: 0.286 Vp-p (DSR-70A) or 0.3 Vp-p (DSR-70AP), 75 Ω (burst level)
Y/R-Y/B-Y (when using DSBK-170 Analog Component Input/Output Board)	BNC type $\times 3$ (with input/output selection switch), component video Y: 1.0 Vp-p, 75 Ω , sync negative R-Y: 0.7 Vp-p, 75 Ω (75% for DSR-70A or 100% for DSR-70AP) B-Y: 0.7 Vp-p, 75 Ω (75% for DSR-70A or 100% for DSR-70AP)

Analog audio input

AUDIO INPUT	XLR 3-pin (female) $\times 2$ $+4/0/-60$ dBu, high impedance, balanced
-------------	---

Timecode input

TC IN	BNC type $\times 1$, SMPTE (DSR-70A)/EBU (DSR-70AP) 0.5 to 18 Vp-p, 3.3 k Ω , unbalanced
-------	---

Output connectors

Digital output

DV IN/OUT (When using optional DSBK-140 or DSBK-160A board)

6-pin IEEE1394 connector ×1

SDTI (QSDI) OUT (When using optional DSBK-150 board)

BNC type ×1, SDTI (QSDI) format (270Mbps)

SDI OUT (When using optional DSBK-160A board)

BNC type ×1, SMPTE 259M (DSR-70A)/ITU-R BT.656 (DSR-70AP), SDI format (270Mbps)

Analog video output

VIDEO OUTPUT 1, 2 (SUPER)

BNC type ×2, composite, 1.0 Vp-p, 75 Ω, sync negative

REF. VIDEO OUT

BNC type ×2 (loop-through), composite sync, 0.286 Vp-p (DSR-70A) or 0.3 Vp-p (DSR-70AP), 75 Ω, sync negative (with burst)

S VIDEO OUT

DIN 4-pin ×1
Y: 1.0 Vp-p, 75 Ω, sync negative
C: 0.286 Vp-p (DSR-70A) or 0.3 Vp-p (DSR-70AP), 75 Ω (burst level)

Y/R–Y/B–Y (when using optional DSBK-170 board)

BNC type ×3 (with input/output selection switch), component video
Y: 1.0 Vp-p, 75 Ω, sync negative
R–Y: 0.7 Vp-p, 75 Ω (75% for DSR-70A or 100% for DSR-70AP)
B–Y: 0.7 Vp-p, 75 Ω (75% for DSR-70A or 100% for DSR-70AP)

Analog audio output

AUDIO OUTPUT

XLR 3-pin (male) ×2, +4/0/–6 dBu (selectable by menu setting), 600 Ω loaded, low impedance, balanced

MONITOR AUDIO

Phono jack ×1, –6 dBu, 47 kΩ load, unbalanced

Headphone output

HEADPHONES Stereo phone jack ×1, $-\infty$ to –20 dBu, 8 Ω, unbalanced

Timecode output

TC OUT BNC type ×1, SMPTE (DSR-70A)/EBU (DSR-70AP)
2.2 Vp-p±3.0 dB, 600 Ω, unbalanced

Control connector

REMOTE D-sub 9-pin ×1, for connection with another DSR-70A/70AP unit or other editing control unit, complied with RS-422A

Power input

DC IN XLR 4-pin (male)

Accessories supplied

Shoulder belt (1)
Connector caps (1 set)
Operating Instructions (1)

Accessories not supplied

DSBK-140 i. LINK/DV Input/Output Board
DSBK-150 SDTI (QSDI) Input/Output Board
DSBK-160A SDI/i.LINK/DV Input/Output Board
DSBK-170 Analog Component Input/Output Board
DSBK-180/180P Dual Video Input Board
BKNW-225 Docking Kit
RCC-5G/10G/30G 9-pin Remote Control Cable (5 m (16 ft)/10 m (33 ft)/30 m (98 ft) in length)
BP-L60/L60A Battery Pack
DC-L90/210 Battery Adaptor
BC-210/210CE/410/410CE/L50/L100/L100CE Battery Charger
AC-DN2A/DN2B/550/550CE/CMA-8A/8ACE AC Adaptor
PDV-64ME/94ME/124ME/184ME Digital Video Cassette (standard size)
PDVM-12ME/22ME/32ME/40ME Digital Video Cassette (mini-size)
DV12CL Cleaning Cassette (standard size)
DVM12CL Cleaning Cassette (mini-size)

Specifications

Related products

DNW-A25/A25P Betacam SX Digital Videocassette
Recorder
ES-7 EditStation
DSR-300/300P Digital Camcorder

Design and specifications are subject to change
without notice.

Note on liquid crystal display panel (LCD monitor)

The liquid crystal display fitted to this unit is
manufactured with high precision technology, giving a
functioning pixel ratio of at least 99.99%. Thus a very
small proportion of pixels (at most 0.01%) may be
“stuck,” constantly on or constantly off. In addition,
over a long period of use, because of the physical
characteristics of the liquid crystal display, such
“stuck” pixels may appear spontaneously.

These problems have been kept to the absolute
minimum, but are an unavoidable characteristic of
liquid crystal technology.

What Is ClipLink?

The ClipLink™ function greatly improves the efficiency of the video production process as a whole by recording various editing-related data on tape when shooting. As such, ClipLink is a revolutionary function that transcends the conventional separation of shooting and editing.

How ClipLink changes video production techniques

The following describes various ways in which ClipLink¹⁾ video production differs from conventional video production.

Recording of ClipLink log data lightens the shooting workload

When you start shooting a scene, ClipLink log data such as the scene number and time code data are automatically recorded into the cassette memory. This eliminates the need for a conventional “shot list” compiled by someone using a stopwatch, clipboard and pencil. You can also designate unwanted scenes as “NG” (no good) and automatically skip all “NG” scenes when editing.

Recorded Index Pictures drastically cut editing time

The ClipLink function also features Index Pictures a time-saving tool for rough editing. Each Index Picture is a compressed image taken from the start of each scene, which is recorded onto the tape as a still picture. When editing, begin by transferring only the Index Pictures and the ClipLink log data to the EditStation’s hard disk. You can also transfer OK scenes only (“NG” scenes are skipped).

Next, begin rough editing by viewing the Index Pictures on the EditStation’s GUI display and rearranging them as you wish. This eliminates the difficult work of matching up a handwritten shot list with recorded scenes. After you have completed this rough editing, you can then transfer only the recordings needed for your video program.

High-speed transfer of recordings

It is also possible to transfer the editing material itself between the DSR-85/85P and ES-7 at four times normal speed. In other words, the transfer can be carried out in one fourth of the real time duration. It is of course possible to carry out a transfer at four times normal speed when backing up video and audio data recorded on the disk drive to the DSR-85/85P, or in the opposite direction when loading data backed up on the DSR-85/85P to the disk drive. Thus the time required is much shorter than with conventional equipment (for which, for example, transferring a 40-minute segment of video takes 40 minutes).

Note

To transfer digital signals (video, audio and time code) recorded on a tape on this unit from the DSR-85/85P to the ES-7 at four times normal speed requires a continuous recorded section of about 40 seconds before the IN point on the recorded tape.

1) The ClipLink system is a video production system which uses the cassette memory function.

Example System Configuration and Operation Flow

The following illustration shows an example system configuration for using the ClipLink function and a typical ClipLink operation flow.

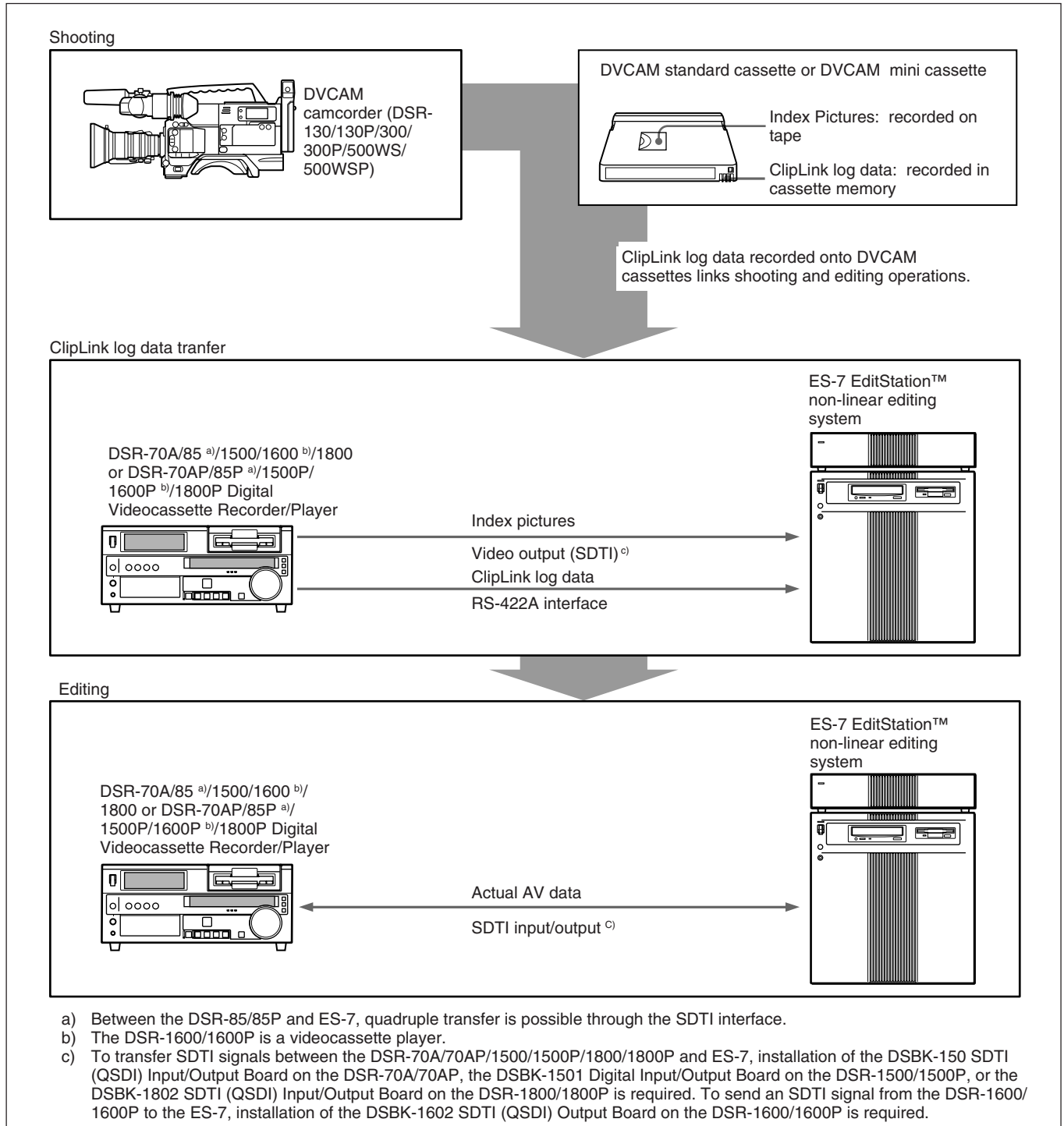

Appendixes

How to record ClipLink log data

The following describes how to record the various ClipLink log data items.

OK/NG status

To designate a scene as “NG,” press the NG button on the camera while shooting the scene or at any time before you begin shooting the next scene.

All scenes that do not receive an “NG” designation are recorded as “OK” scenes.

(When you exit the VTR recording mode, changing the OK/NG status is no longer possible.)

Mark IN/OUT points time codes

This data is especially useful when shooting a video program for which a scenario has been created. Set the camera to MARK mode before you start shooting. While shooting, each time you press the camera’s TAKE button, Mark IN and Mark OUT time codes are recorded alternately.

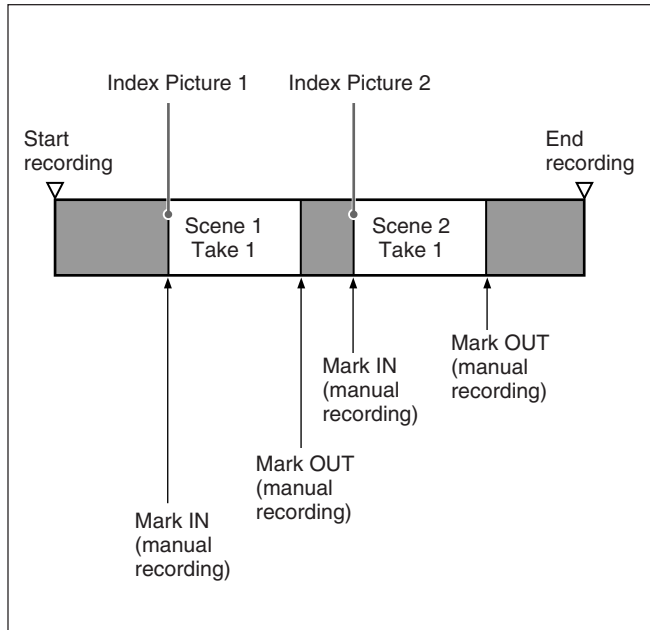

Cue point time codes

This type of data is especially useful when shooting scenes that may contain unexpected events, such as when shooting for sports coverage or documentaries. Set the camera to CUE mode before you start to record. While recording, each time you press the camera’s TAKE button, the current time code is recorded as a cue point time code.

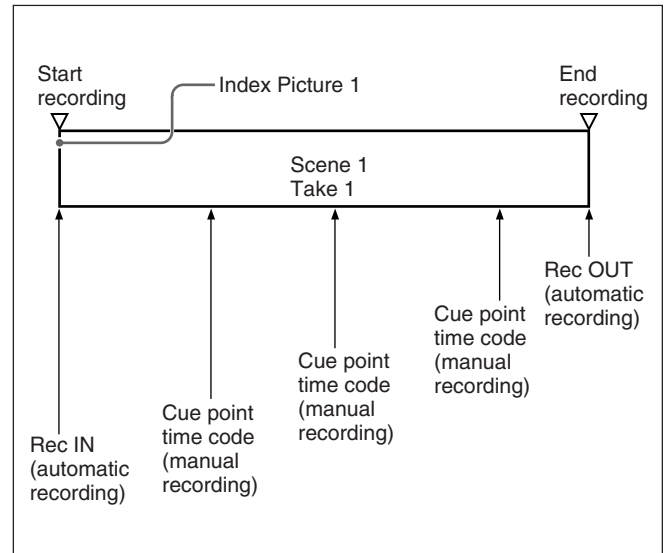

Time codes recorded for Mark IN/OUT points

There is a gap between actual time codes and Mark IN/OUT time codes recorded in the cassette memory, as shown in the figure below. The frame digit is incremented at each Mark IN point and is decremented at each Mark OUT point.

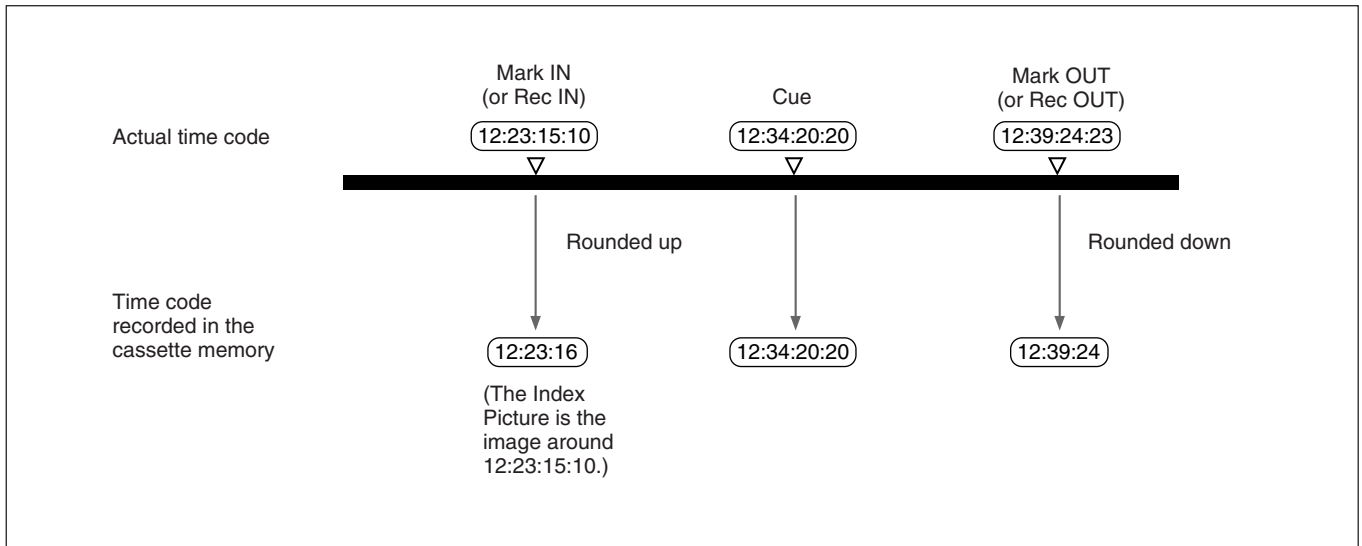

Recording capacity for Mark IN/OUT time codes and Cue point time codes

When in MARK mode, up to 198 pairs of Mark IN and Mark OUT points can be recorded (if using a cassette with 16 Kbits of cassette memory).

When in CUE mode, up to 396 time codes points (including all cue point time codes and all Mark (Rec) IN and Mark (Rec) OUT time codes) can be recorded (if using a cassette with 16 Kbits of cassette memory).

Assemble editing

Editing in which new video/audio is added in sequence to the end of existing recorded video/audio. *See also* "Insert editing."

Bridge connection

A connection which allows a signal input to an input terminal to pass through the unit and exit from an output terminal as input to external equipment.

B-Y signal

One of the color difference signals, the B (blue) signal minus Y (luminance) signal.

C signal

See "Chrominance signal."

Capstan

A drive mechanism that moves the tape at a specified speed. Its rotation is normally synchronized with a reference sync signal.

Chrominance signal

A signal which carries information about hue and saturation. Also called "C signal."

Condensation

Moisture which condensed on tape transport mechanisms. If there is condensation on the head drum, tape sticks to drum and the VCR may malfunction.

Component video signal

A signal that consists of a luminance signal (Y) and two chrominance signals (R-Y, B-Y).

Composite video signal

A signal that consists of video, sync and color burst signals.

CTL

Control signal in the form of regular pulses recorded along a longitudinal track on the videotape. By counting these pulses, it is possible to determine the number of frames, and hence the tape's running time. Used mainly to adjust the tracking position of video heads, and to achieve timecode continuity in continuous recording.

Digital VCR

On a digital VCR, video and audio signals are recorded on magnetic tape and, unlike on an analog VCR, can be played back without any quality deterioration.

Drop frame mode

Time code runs at 30 frames/sec. The NTSC system, however, runs at about 29.97 frame /sec. Drop frame mode adjusts this difference. The timecode and video are synchronized by dropping the first two frames of the timecode every minute, except at the ten-minute marks.

Drum

See "Head drum."

E-E mode

Abbreviation of "Electric to Electric" mode. In this mode, video and audio signals input to the VCR are output after passing through internal electric circuits, but not through magnetic conversion circuits such as heads and tapes. This can be used to check input signals and for adjusting input signal levels.

Emphasis

The signal is emphasized at high frequencies. During playback, it is de-emphasized. This suppresses noise without affecting the original signal.

External lock/Gen-lock

Synchronizing one equipment (controlled or slave unit) to another (controlling or master unit). The signal and tape run of the VCRs used for editing, player and recorder, are usually synchronized.

Gen-lock (generator lock)

See "External lock."

Head drum

A metal cylinder to which a video head is attached. This drum is rotated at high speeds in synchronization with the sync signal during recording and playback.

Insert editing

Editing in which new video/audio is added into the middle of existing recorded video/audio. *See also* "Assemble editing."

IRE

A unit for representing a video level laid down by the IRE (Institute of Radio Engineers). The IRE is now the IEEE (Institute of Electric and Electronic Engineers).

Linear editing

Editing while playing back video and audio signals recorded on video tape. *See also* "Non-linear editing."

Loading

Also called "threading." To pull the tape out of the cassette case, thread it along the specified tape path, and wrap it on the drum in order to prepare it for recording or playback. The VCR automatically loads the cassette tape when you insert the cassette into the cassette compartment. There are two loading modes: standby-on mode and standby-off mode.

LTC

Abbreviation of "Longitudinal Time Code." This timecode is recorded on a longitudinal track on the tape. Reading is unreliable at low speeds, and not possible at all during still playback. *See also* "VITC."

Luminance signal

A signal that determined the brightness of the picture. Also called "Y signal."

Non-drop frame mode

The number of frames of the timecode and video run is not adjusted. When you use the timecode in non-drop frame mode, the real playback time will be about 86 seconds shorter per day than the timecode. If you edit frame by frame or if you determine the length of a shot by counting the timecode, use drop frame mode.

Non-linear editing

Editing while playing back video and audio signals recorded on hard disks. Video scenes stored on disk can be cued up quickly, for increased editing efficiency. *See also* "Linear editing."

Preroll

Running of a video tape to a prior to an edit-start point to enable the tape to reach a steady speed and to be synchronized with other video tapes.

Quantization

The level resolution when an analog signal is sampled before converted into a digital signal. 8-bit quantizing has 256 levels and 16-bit quantizing has 1024 levels. Generally, 8-bit quantizing is used for video signals and 16-bit quantizing is used for audio signals. The fewer the quantizing steps, the more distortion is in the analog signal when the digital signal is reconverted into analog signal.

Reference video signal

A video signal which contains a sync signal or sync and burst signals, used as a reference for synchronization of video equipment.

R–Y signal

One of the color difference signals, the R (red) signal minus Y (luminance) signal.

Sampling frequency

The unit of time used when converting an analog signal with a continuously varying level to digital form by sampling the level at a fixed interval. In general, a higher sampling frequency makes it possible to digitize analog signals of a higher frequency.

SCH

Abbreviation of Sub Carrier to Horizontal. The phase of the subcarrier with respect to the phase of the horizontal synchronization signal. In editing of monochrome video, phase continuity is maintained by editing in units of frames (two fields), so that the continuity of the horizontal synchronization signal phase is maintained. Editing of color video must be done in units of two frames (four fields) to maintain subcarrier continuity. The SCH of a field can be checked to find out which of the four fields it represents. This allows edited video signals to be joined while maintaining subcarrier continuity.

Search

Viewing the picture or timecode by running the tape in fast forward or rewind mode, in order to search for a particular scene.

Servo

A mechanism that controls the number and phase of rotations of the head drum or capstan. Servo mechanism allows playback of the video signal without guard band noise. The reference signal of the servo control is normally a vertical sync signal.

Servo lock

This refers to the synchronization of the phase of the drum rotation and the reference signal for the tape transport position, so that the video heads can trace the same pattern on the tape for playback and recording.

Setup (for DSR-70)

The difference between the reference black level and the blanking level of a composite signal.

SMPTE

Abbreviation of Society of Motion Picture and Television Engineers, a professional association established in the USA.

S/N

Signal-to-Noise ratio. The relation of the strength of the desired signal to the accompanying electronic interference, the noise. If S/N is high, sounds are reproduced with less noise and pictures are reproduced clearly without snow.

Standby-off mode

One of the stop modes. In this mode, head drum rotation is stopped and the tape tension is slackened. It is not possible to switch instantaneously from this mode to recording or playback mode. This mode is not harmful to the tape or heads.

Standby-on mode

One of the stop modes. In this mode, the head drum continues rotating and the tape remains wound onto the drum. This mode enables instantaneous switching to recording or playback mode. To prevent damage to the tape or heads, the device automatically switches from standby-on mode to standby-off mode after a certain period of time.

Subcarrier

Color information contained in a composite video signal. Its amplitude is for color saturation and its phase to color burst is for hue.

Superimpose

To put one picture (or characters) onto another so that both can be seen at the same time.

S-video

A signal format in which Y (luminance) and C (chrominance) signals are separated to reduce interference between them so that noiseless images are reproduced.

Sync

A reference signal consisting of vertical and horizontal sync signals used for synchronizing the scanning patterns of the video camera and the monitor.

Synchronization

In video editing, alignment of the position and speed of player and recorder VCRs tapes. Carried out during preroll in order to increase editing precision.

Tape tension

The tension applied to a tape. For the tape to run properly while being wound on the drum, it must be pulled lightly in the opposite direction to the direction of transport. Improper adjustment of tape tension can cause deviations along the temporal signal axis. In analog VCRs, these deviations are evident as skew and distortion in the upper part of the screen.

TBC

Abbreviation of Time Base Corrector. Electronic circuits to electrically stabilize the playback signals by removing color variation and roll in the playback picture caused by irregularity in drum rotation and tape movement. Time base correction reduces deterioration of picture quality when transmitting or copying playback signals.

Threading

See "Loading."

Time code

The timecode is a tape position information signal that includes time and frame data that are recorded onto the tape so as to facilitate searching of editing points and recorded scenes when viewing or editing.

SMPTE timecode is applied to NTSC system, and EBU timecode is applied to PAL/SECAM systems. There are two kinds of signal recorded on tape. One is longitudinal timecode (LTC) recorded along the tape (the same way as audio and CTL signals). The other is vertical interval timecode (VITC). This code is inserted in the vertical blanking period and it is recorded on the tape with video signals.

Time data

This refers either to time data that is generated by a timecode generator or time data that is played back from a tape and read by a timecode reader.

Unloading

When the EJECT button is pressed, the VCR automatically winds the tape back into the cassette case. Also called "Unthreading."

Glossary

Unthreading

See “Unloading.”

User bits

These are also referred to as “user’s bits.” The user bits are a 32-bit segment of the timecode recording area. The user can select what to record in this segment and how to use the recorded data. For example, it can be used to record date information in addition to the timecode data or ID numbers for tape reels or programs.

V (vertical)-blanking

The portion of the video signal that occurs between the end of one field and the beginning of the next. During this time, the electron beams in monitors are turned off so that they can return from the bottom of the screen to the top without showing tracks of movement on the screen. When the position of v-blanking is not adjusted correctly, a horizontal black bar appears on the screen.

Video gain

Amount of amplification for video signals, expressed in decibels (dB).

VITC

Abbreviation of “Vertical Interval Time Code.” This timecode is inserted in the vertical blanking interval and recorded on the video tracks. It can be read at low speeds and during still playback, but not during high-speed playback.

See also “LTC.”

Y signal

See “Luminance signal.”

A

- AC power 34
- AC-DN2A/DN2B 35
- AC-550/550CE 35
- AGC 68
- Alarm messages 139
- Analog interfaces 10
- ASSEMBLE button/indicator 22
- Assemble editing 77
- Audio
 - control section 23
 - input level adjustment 42
 - input/output settings 68
 - level meter 17
 - mode indication 64
 - monitor speaker 17
 - recording mode indication 65
 - setting page selection indication 65
 - settings pages 68
 - settings subpages 69
- AUDIO CH buttons 22
- AUDIO IN button 23
- AUDIO INPUT
 - adjustment knobs 24
 - connectors 27
 - level switches 26
 - PRESET/VARIABLE switch 24
- AUDIO OUTPUT connectors 27
- AUTO EDIT button 23

B

- BACKLGT setting 72
- BAT-END setting 72
- BAT-NE setting 72
- Batteries 31
- Battery connector 25
- Battery pack 32, 33
- BAT-TYP setting 72
- BP-L60(A)/L90(A) 32
- BP-90(A) 33
- BREAKER button 26
- BRIGHT/CONTRAST knob 16

C

- Cassettes 37
 - compartment 21
 - DVCAM 38
 - loading 40
 - sizes 10, 37
- CHARACTER setting 71

- CHROMA knob 24
- CHROMA PHASE knob 25
- ClipLink 11
 - adding mark IN/OUT points 99
 - adding/deleting log data 99
 - automatically creating new log data 101
 - changing mark IN/OUT points 96
 - changing OK/NG status 97
 - changing reel number 96
 - cuing up 95
 - deleting mark IN/OUT points 99
 - displaying ClipLink log data 94
 - guide 147
 - operation 93
 - rewriting ClipLink log data 96
- CLIPLINK indication 64
- Combining two VCRs 132
- Component analog recording 124
- Condensation 135
- Connections for 119
 - component analog recording 124
 - cut editing 120
 - cut editing using SDI interface 122
 - digital nonlinear editing 121
 - digitally dubbing VCAM signals 131
 - i.LINK connections 120
 - parallel recording 127
 - sequential recording 125
 - two-input switched video recording 130
 - two-unit synchronous playback 129

Continuous editing 91

Control panel 18

COUNTER SELECT button 16

Cuing up

- any desired position 95
- edit points 81
- mark IN/OUT and cue points 95

Cut editing using SDI interface 122

Cut editing using two units 120

D

- DC IN connector 28
- DELETE button 23
- DF/NDF setting 71
- Digital
 - dubbing in DVCAM format 50
 - hours meter 136
 - interfaces 10
 - jog sound 11
 - nonlinear editing using SDTI (QSDI) 121
 - slow motion playback 11

- Display panel 16
- DMC editing 10, 87
- DSBK-140 12, 29
- DSBK-150 12, 29
- DSBK-160A 13, 29
- DSBK-170 13, 29
- DSBK-180/180P 13
- Dubbing DVCAM signals 131
- DVCAM cassettes 38
- DVCAM format 9
- DVCPRO 10

E

- Edit 73
 - executing 84
 - list 86
 - mode 77
 - monitoring 84
 - previewing 82
 - redoing 85
 - settings 74
 - special editing 90

EDIT button 20

Edit points

- checking 81
- cuing up 81
- deleting 83
- finding 79
- modifying 83
- setting 80

Editing section 22

E-E mode 16, 19, 20

EJECT button 21

ENTRY/SHIFT button 23

Error messages 139

External lock 63

F

- F FWD button 20
- 48V ON/OFF switches 26
- Front control section 24
- F-RUN/R-RUN setting 71

G

General settings pages 71

H

Head cleaning 135
HEADPHONES jack 25
HOLD button 16

I

i.LINK (DV) 10
i.LINK connections 120
IN/OUT buttons 23
Input
 audio signal indication 65
 settings 68
 video signal indication 65
INSERT buttons/indicators 22
Insert editing 77
Interfaces 10

J

Jog and shuttle dials 20
Jog mode 79

K

KEY INH setting 72

L

LCD monitor 16, 59
Level adjustment knobs 24
LEVEL knob 25
LIGHT switch 16
LIGHTSW setting 72
LIMITER 68
LINE OUT 69

M

Maintenance 135
Manual editing 92
Mark IN/OUT points 96, 99
MENU button 21
Menus
 setup menu 103
 sub LCD menu 64
METER switch 16
MIX/SWAP CH 1 to 4 68
MONI.VR 69
MONITOR 69, 70
 AUDIO connector 27

N

NO EDIT indication 65

O

OK/NG status 97
Operating mode settings 64
Optional boards 12
Optional board fitting port 28
Output settings 68
Output video signal phase 48

P

PAGE button 17, 64
Panels
 control panel 18
 display panel 16
 rear panel 26
 top panel 25
Parallel recording 44
 connections 127
PB AUDIO level adjustment sliders 24
PB AUDIO PRESET/VARIABLE
 switch 24
PB/EE setting 71
PCM digital audio 9
Periodic maintenance 136
PLAY button 20
Playback 55
 compatibility 10
 digital slow motion playback 11
 setting playback speeds 88
 synchronous playback 57
Player settings 76
PLAYER/DMC button/indicator 21
POWER indicator 25
Power preparations 31
POWER switch 25
PP MODE 70
PP POSI. 70
PP SIZE 70
Preroll 82
PREROLL button 19
PRESET/REGEN setting 71
PREVIEW button 23
Previewing edit results 82
PROCESS CONTROL 70

Q

Quick editing 90

R

Rear panel 26
REC INHI indicator 19
REC INHI switch 21
REC/SEQ button 19
RECORDER button/indicator 21
Recorder settings 74
Recording 42
 parallel 44
 sequential 12, 43
 timecode 61
 two-input video 11, 46
Redoing an edit 85
Reel number 96
REF. VIDEO IN/OUT connectors 27
Reference video for analog signal
 editing 119
Remaining battery power indication 65
Remaining tape time indication 65
REMOTE connector 28
REMOTE setting 71
REMOTE/LOCAL switch 18
RESET button 16
REVIEW button 23
REW button 20

S

S VIDEO IN/OUT connectors 27
SDI 10
SDTI (QSDI) 10
Search 79
Search button/indicators 20
Sequential recording 12, 43
 connections 125
SERVO indicator 20
SET button 22
SET UP/BLACK LEVEL knob 25
Setup menu 103
 basic menu items 103
 basic menu operations 106
 configuration 103
 extended menu items 109
 extended menu operations 117
 menu bank operations 108
 section 21
75-ohm termination switch 27

Shoulder belt 133
Shuttle dial 20
Shuttle mode 79
Special editing 90
 continuous editing 91
 manual editing 92
 quick editing 90
Specifications 143
Split editing 11
STANDBY indicator 20
STOP button 20
Sub LCD 17
Sub LCD menu 68
 basic operations 66
 display and settings 64
 general settings pages 71
 home page 64
Sub LCD operation buttons 17, 64
Superimposed text 12, 59
Synchronizing internal timecode
 generator 63
System configuration 14

T

Tape transport section 19
TC button 22
TC IN connector 28
TC INT/EXT switch 21
TC OUT connector 28
TC SELECT switch 21
Time data 59
 display area 64
 indication 64
Timecode
 generator/reader 11
 operation buttons 16
 recording 61
 section 21
 setting initial value 61
 synchronizing internal timecode
 generator 63
Top panel 25
TRIM/CLIPLINK buttons 22
Troubleshooting 137
Two-input switched video recording
 46, 130
Two-unit synchronous playback 129

U

UP and DOWN buttons 17
UP/DOWN buttons 64
User bits 62

V

Variable speed mode 79
Video
 input/output settings 68
 process control 11
 settings page 70
VIDEO
 button 22
 INPUT connectors 27
 knob 24
 OUTPUT connectors 27
VITC indication 64
VITC setting 71

W, X, Y

WARNING indicator 16
WIDE 70
Wide screen 12
Wide track 9

Z

ZEBRA 70

Sony Corporation

<http://www.sony.net/>